

# Cutter Pumps SFC620...2320

Axial/semi-open impellers

## SFC620...1120

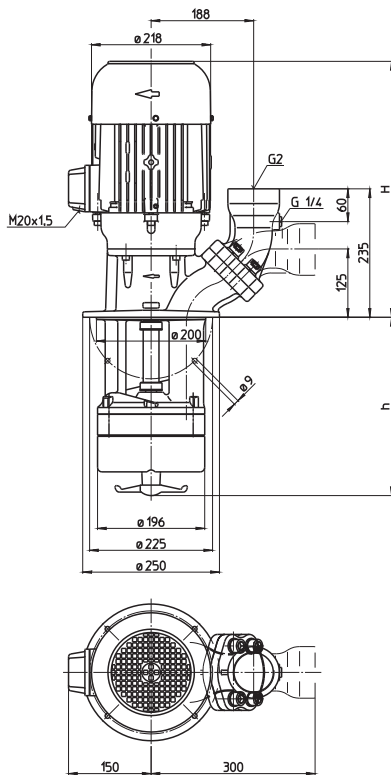

Type	Vol. del. at manom. del. head l/min / m	Height H mm	Depth of immersion h mm	Weight kg	Power kW	Voltage 3~ V	Fre- quen- cy Hz	Current A	Speed 1/min
SFC620/290	400/8	503	292	71	3.3	220-240	50	11.6	2930
390			392	74		380-415	50	6.7	2930
520			522	76					
640			642	79					
SFC820/290	400/10	503	292	73	4.0	220-240	50	14.50	2920
390			392	76		380-415	50	8.35	2920
520			522	78					
640			642	81	4.55	460	60	7.9	3520
SFC1120/290	500/12	533	292	78	5.5	220-240	50	18.9	2915
390			392	81		380-415	50	10.9	2915
520			522	85					
640			642	88	6.3	460	60	10.4	3510
SFC1520/370	700/16	612	372	144	7.5	380-415	50	14.3	2950
500			502	149					
620			622	153	8.6	460	60	13.7	3550
SFC1820/370	800/20	620	372	173	11.0	380-415	50	20.1	2960
500			502	176					
620			622	180	12.6	460	60	19.5	3560
SFC2320/400	900/28	974	400	223	18.5	400	50	32	2955
530			530	227					
650			650	233	21.3	460	60	32	3555

## SFC1520...2320

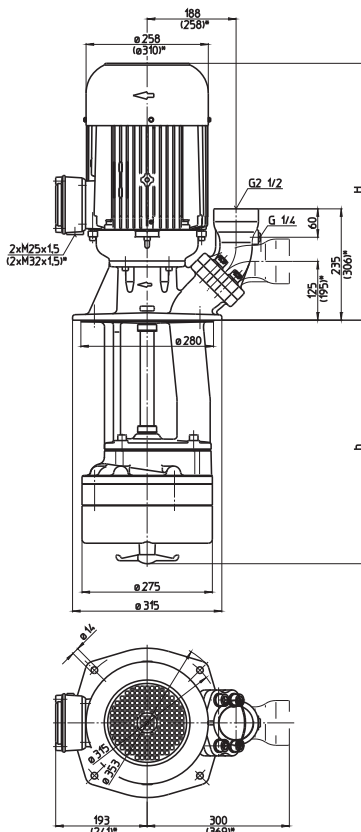

\*) Dimensions for SFC1820  
Dimensions SFC2320 above flange as with SGL1420

### Cutter Pumps

The cutter pumps of the **series SFC** are capable of cutting aluminium chips and similar materials and pumping of these materials along with the coolant fluid. An agitator located at the pump suction helps to break up and separate any large bundles of chips or birds nests which reach the pump suction.

The specially made cutting unit (> 60HRC) is cutting chips and the above located semi-open impeller allows with its large clearances to pump the particles along with the coolant fluid from the machine back to the filter. The SFC pumps are capable of handling chip to coolant ratios of up to 1.5% by weight. The SFC pumps are equipped with the user-friendly 45 degree **flange** connection which allows for either vertical or horizontal pipe connection and the connection of a pressure gauge with G 1/4.

For more information see lifting pumps features SFC/SBC within the technical information section.



### Applications

Types of fluid  
coolants  
cooling/cutting oils on request  
Max. chip to coolant ratio by weight:  
1.5 %  
Chip material:  
Aluminium  
Kinematic viscosity  
...45 mm<sup>2</sup>/s (45 cSt)  
Pumping temperature  
0...80° C

### Construction

Pump body	cast iron
Cover	cast iron
Impeller radial	cast steel
Cutting unit	Hardened (>60 HRC)
Agitator	Highly ductile steel
Shaft	steel

