

**ZASUWA KLINOWA KOŁNIERZOWA STALIWNA Z NAPĘDEM ELEKTROMECHANICZNYM** Nr katalogowy **055**  
**PN 25** **AUMA - TYP NAPĘDU A - Układ N51** **055 A**

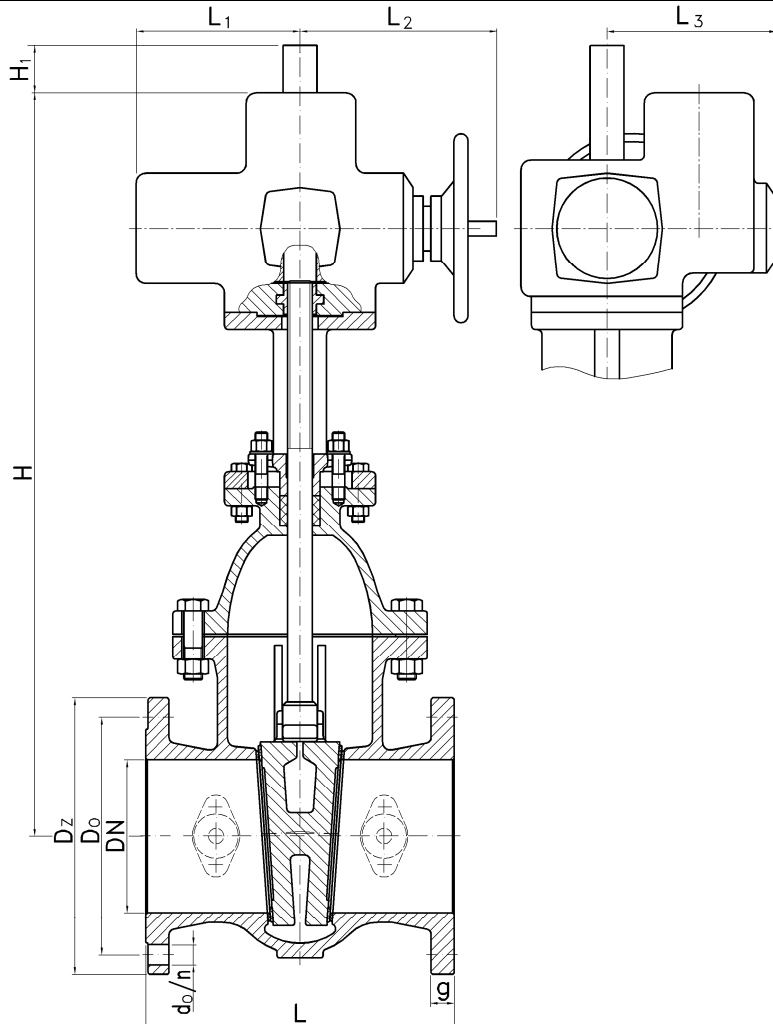

DN	Dz	Do	d <sub>0</sub> / n	g	L	H	H <sub>1</sub>	L <sub>1</sub>	L <sub>2</sub>	L <sub>3</sub>	Typ i wielkość napędu	Nastawa Nm	i <sup>1</sup>	Masa 055 <sup>2</sup>	Masa 055 A <sup>2</sup>
40	150	110	18 / 4	18	240	535	--	265	234	237	SA07.1-F10-A	18	14,5	43,6	--
50	165	125	18 / 4	20	250	545	--	265	234	237	SA07.1-F10-A	22	16,0	49,0	--
65	185	145	18 / 8	22	270	600	--	265	234	237	SA07.1-F10-A	28,5	20,0	54,0	--
80	200	160	18 / 8	24	280	640	--	265	250	237	SA07.5-F10-A	35	24,0	67,5	--
100	235	190	22 / 8	24	300	700	--	265	250	237	SA07.5-F10-A	45	22,5	83,0	--
125	270	220	26 / 8	26	325	775	--	282	256	247	SA10.1-F10-A	67	29,0	114,0	--
150	300	250	26 / 8	28	350	865	--	282	256	247	SA10.1-F10-A	90	34,5	138,0	--
200	360	310	26 / 12	30	400	1071	--	385	325	285	SA14.1-F14-A	177	36,0	247,0	257,0
250	425	370	30 / 12	32	450	1190	60	385	325	285	SA14.1-F14-A	255	44,5	330,0	342,0
300	485	430	30 / 16	34	500	1338	100	385	332	285	SA14.5-F14-A	314	54,5	431,0	453,0
350	555	490	33 / 16	38	550	1485	170	385	332	285	SA14.5-F14-A	392	54,2	572,0	607,0
400	620	550	36 / 16	40	600	1655	185	510	355	307	SA16.1-F16-A	680	61,1	832,0	868,0
500	730	660	36 / 20	44	700	1910	240	520	405	366	SA25.1-F25-A	1190	59,6	1336,0	1385,0
600	845	770	39 / 20	46	800	2370	340	520	405	366	SA25.1-F25-A	1570	70,9	1983,0	2046,0

<sup>1</sup> Ilość obrotów potrzebna do otwarcia zasuw

<sup>2</sup> Podane masy dotyczą zasuw z napędem