

Free of maintenance stop valve with bellows seal - metallic sealing
DN 10 - 100

ARI-FABA®-Supra
Straight through with flanges

- Rising handwheel
- TRB 801 Annex II Nr. 45

Cast steel
Forged steel
High temp. steel

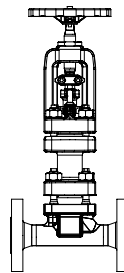

Fig. 146

Page 2

ARI-FABA®-Supra
Straight through with butt weld ends

- Rising handwheel
- TRB 801 Annex II Nr. 45

Cast steel
Forged steel
High temp. steel

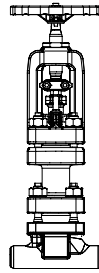

Fig. 140

Page 4

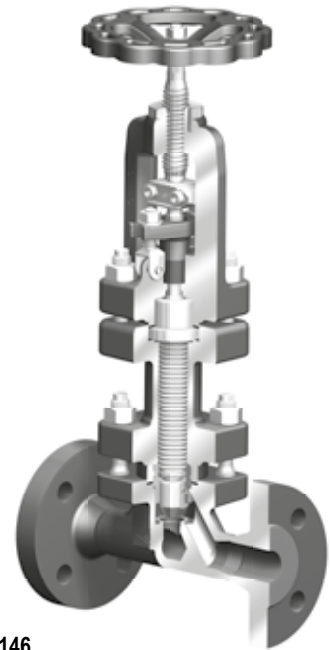

Fig. 146

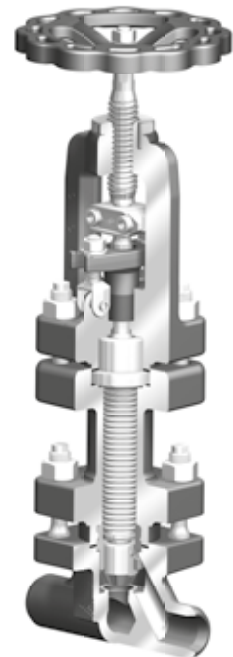

Fig. 140

Features:

- Multi-wall bellows seal, out of the media flow path
- Bellows seal 10.000 load cycles
- Bellows seal stem with back seat as standard
- Double chambered yoke gaskets
- Grooved gaskets
- Plug with marginal seat
- Guided plug, hardened / stellite
- Seat stellite
- Upper stem with roll hardened thread
- External stem thread
- Secondary sealing: gland packing / bridge with flap type screw

Stop valve - straight through with flanges and bellows seal (Forged steel, High temperature steel)

Figure	Nominal pressure	Material	Nominal diameter
46.146...40	PN63	1.0460	DN10-50
47.146...40	PN100	1.0460	DN10-50
48.146...40	PN160	1.0460	DN10-50

86.146...81	PN63	1.7335	DN10-50
87.146...81	PN100	1.7335	DN10-50
88.146...81	PN160	1.7335	DN10-50

Larger nominal diameters refer to page 3..

Parts				
Pos.	Sp. p.	Description	Fig. 46./47./48.146...40	Fig. 86./87./88.146...81
1		Body	P250 GH, 1.0460	13CrMo4-5, 1.7335
1.2		Seat	Stellit 21	
2	x (unit)	Bonnet	GP240GH+N, 1.0619+N	G17CrMo5-5, 1.7357
3		Plug	X20Cr13+QT, 1.4021+QT (hardened)	13CrMo4-5, 1.7335 / Stellit 6
4		Spindle unit		
4.1		Bellows seal	X6CrNiMoTi17 12 2, 1.4571	
4.2		Stem	X6CrNiMoTi17 12 2, 1.4571	
6		Packing ring	Pure graphite	
15		Insert nuts	CuZn35Ni3Mn2AlPb, CW710R	
44		Stem, top	X39CrMo17-1+QT, 1.4122+QT	
94	Bellows housing	GP240GH+N, 1.0619+N	G17CrMo5-5, 1.7357	
5		Handwheel	EN-GJS-400-15, EN-JS1030 (FE 13 epoxy-coating)	
7		Stud-bolt	21CrMoV 5-7, 1.7709	
8		Hexagon nut	21CrMoV 5-7, 1.7709	
9	x	Gasket	Pure graphite 99,85% (with Cr-Ni-grooved)	
L Spare parts				

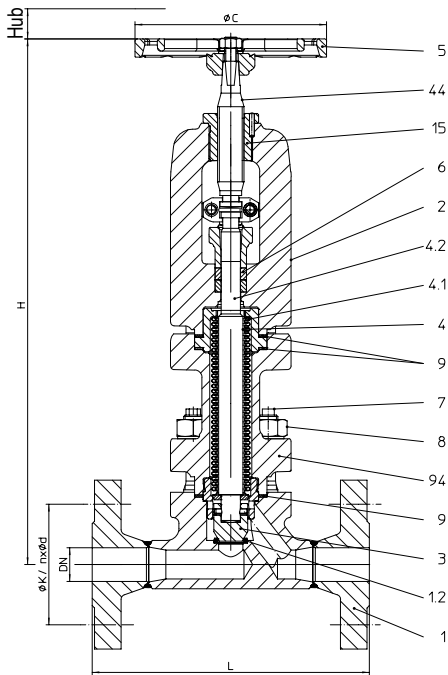
DN	10	15	20	25	32	40	50
----	----	----	----	----	----	----	----

Face-to-face dimension FTF serie 2 acc. to DIN EN 558		Standard-flange dimensions refer to page 6						
L	(mm)	210	210	230	230	260	260	300

Dimensions								
H	(mm)	438	438	438	438	589	589	656
ØC	(mm)	160	160	160	160	225	225	225
Travel	(mm)	12	12	12	12	17	17	21
Kvs-value	(m³/h)	2,7	5,9	7,2	8,6	18	21	30
Zeta-value	--	2,2	2,3	4,9	8,4	5,2	9,3	11,1

Zeta-value ... range of tolerance for Kvs-values acc. to VDI/VDE 2173

Seat tightness: Leakage rate A acc. to DIN EN 12266-1

Weights								
46./86.146	(kg)	16,6	16,9	18,5	19,5	38	39,6	42,6
47./87.146	(kg)							46,2
48./88.146	(kg)							

Information / restriction of technical rules need to be observed!

Operating and installation instructions can be downloaded at www.ari-armaturen.com.

A production permission acc. to TRB 801 No. 45 is available.

The engineer, designing a system or a plant, is responsible for the selection of the correct valve.

Resistance and fitness must be verified, contact manufacturer for information (refer to Product overview and Resistance list).

Stop valve - straight through with flanges and bellows seal (Cast steel, High temperature steel)

Figure	Nominal pressure	Material	Nominal diameter
36.146...30	PN63	1.0619+N	DN65-100
37.146...30	PN100	1.0619+N	DN65-100
38.146...30	PN160	1.0619+N	DN65-100
86.146...89	PN63	1.7357	DN65-100
87.146...89	PN100	1.7357	DN65-100
88.146...89	PN160	1.7357	DN65-100
Smaller nominal diameters refer to page 2..			
At high differential pressures a balancing plug is necessary! (refer to page 8)			

Parts				
Pos.	Sp. p.	Description	Fig. 36./37./38.146...30	Fig. 86./87./88.146...89
1		Body	GP240GH+N, 1.0619+N	G17CrMo5-5, 1.7357
1.2		Seat	Stellit 21	
2	x (unit)	Bonnet	GP240GH+N, 1.0619+N	G17CrMo5-5, 1.7357
3		Plug	X20Cr13+QT, 1.4021+QT (hardened)	13CrMo4-5, 1.7335 / Stellit 6
4		Spindle unit		
4.1		Bellows seal	X6CrNiMoTi17-12-2, 1.4571	
4.2		Stem	X6CrNiMoTi17-12-2, 1.4571	
6		Packing ring	Pure graphite	
15		Insert nuts	CuZn35Ni3Mn2AlPb, CW710R	
44		Stem, top	X39CrMo17-1+QT, 1.4122+QT	
94		Bellows housing	GP240GH+N, 1.0619+N	G17CrMo5-5, 1.7357
5		Handwheel	EN-GJS-400-15, EN-JS1030 (FE 13 epoxy-coating)	
7		Stud-bolt	21CrMoV 5-7, 1.7709	
8		Hexagon nut	21CrMoV 5-7, 1.7709	
9	x	Gasket	Pure graphite 99,85% (with Cr-Ni-grooved)	
	L Spare parts			

DN	65	80	100
----	----	----	-----

Face-to-face dimension FTF serie 2 acc. to DIN EN 558		Standard-flange dimensions refer to page 6		
L	(mm)	340	380	430

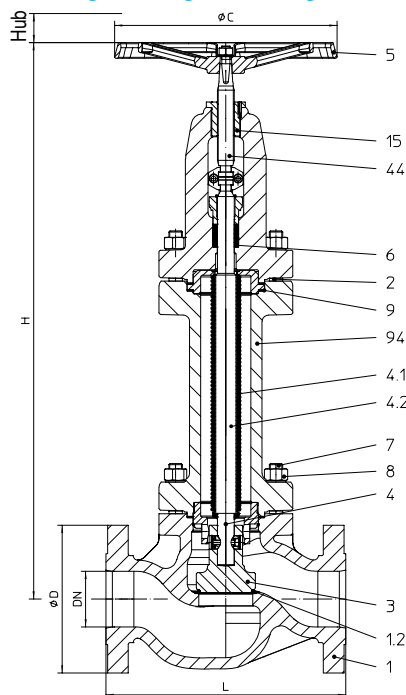
Dimensions				
H	(mm)	843	924	998
ØC	(mm)	400	400	400
Travel	(mm)	27	32	39
Kvs-value	(m³/h)	78	122	180
Zeta-value	--	4,7	4,4	4,9
Zeta-value ... range of tolerance for Kvs-values acc. to VDI/VDE 2173				
Seat thightness: Leakage rate A acc. to DIN EN 12266-1				

Weights				
36./38.146	(kg)	84,9	123	152
37./87.146	(kg)	93,6	135	170
38./88.146	(kg)			

Information / restriction of technical rules need to be observed!

Operating and installation instructions can be downloaded at www.ari-armaturen.com.

A production permission acc. to TRB 801 No. 45 is available.

The engineer, designing a system or a plant, is responsible for the selection of the correct valve.

Resistance and fitness must be verified, contact manufacturer for information (refer to Product overview and Resistance list).

Stop valve - straight through with butt weld ends and bellows seal (Forged steel, High temperature steel)

Figure	Nominal pressure	Material	Nominal diameter
46.140...40	PN63	1.0460	DN10-50
47.140...40	PN100	1.0460	DN10-50
48.140...40	PN160	1.0460	DN10-50

86.140...80	PN63	1.5415	DN10-50
87.140...80	PN100	1.5415	DN10-50
88.140...80	PN160	1.5415	DN10-50
86.140...81	PN63	1.7335	DN10-50
87.140...81	PN100	1.7335	DN10-50
88.140...81	PN160	1.7335	DN10-50

Larger nominal diameters refer to page 5..

Butt weld ends according to DIN EN 12627 (refer to page 6)

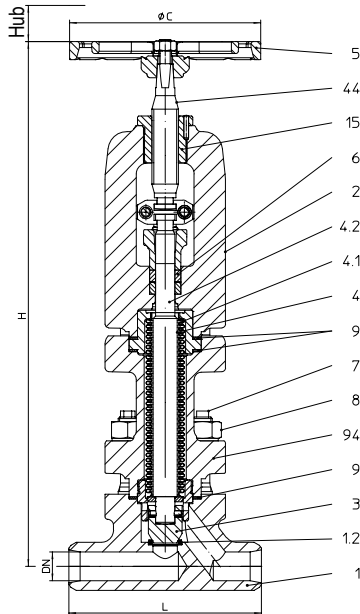
Parts					
Pos.	Sp. p.	Description	Fig. 46./47./48.140...40	Fig. 86./87./88.140...80	Fig. 86./87./88.140...81
1		Body	P250 GH, 1.0460	16Mo3, 1.5415	13CrMo4-5, 1.7335
1.2		Seat	Stellit 21		
2	x (unit)	Bonnet	GP240GH+N, 1.0619+N	G17CrMo5-5, 1.7357	
3		Plug	X20Cr13+QT, 1.4021+QT (hardened)	13CrMo4-5, 1.7335 / Stellit 6	
4		Spindle unit			
4.1		Bellows seal	X6CrNiMoTi17 12 2, 1.4571		
4.2		Stem	X6CrNiMoTi17 12 2, 1.4571		
6		Packing ring	Pure graphite		
15		Insert nuts	CuZn35Ni3Mn2AlPb, CW710R		
44		Stem, top	X39CrMo17-1+QT, 1.4122+QT		
94		Bellows housing	GP240GH+N, 1.0619+N	G17CrMo5-5, 1.7357	
5			Handwheel	EN-GJS-400-15, EN-JS1030 (FE 13 epoxy-coating)	
7		Stud-bolt	21CrMoV 5-7, 1.7709		
8		Hexagon nut	21CrMoV 5-7, 1.7709		
9	x	Gasket	Pure graphite 99,85% (with Cr-Ni-grooved)		
L Spare parts					

DN	10	15	20	25	32	40	50
----	----	----	----	----	----	----	----

Face-to-face dimension ETE serie 65 acc. to DIN EN 12982								
L	(mm)	150	150	150	160	180	210	250

Dimensions								
H	(mm)	438	438	438	438	589	589	656
ØC	(mm)	160	160	160	160	225	225	225
Hub	(mm)	12	12	12	12	17	17	21
Kvs-value	(m³/h)	2,7	5,9	7,2	8,6	18	21	30
Zeta-value	--	2,2	2,3	4,9	8,4	5,2	9,3	11,1

Zeta-value ... range of tolerance for Kvs-values acc. to VDI/VDE 2173

Seat tightness: Leakage rate A acc. to DIN EN 12266-1

Weights								
46./47./48.140 86./87./88.140	(kg)	14,5	14,5	14,5	14,5	31,2	31,6	34,9

Information / restriction of technical rules need to be observed!

Operating and installation instructions can be downloaded at www.ari-armaturen.com.

A production permission acc. to TRB 801 No. 45 is available.

The engineer, designing a system or a plant, is responsible for the selection of the correct valve.

Resistance and fitness must be verified, contact manufacturer for information (refer to Product overview and Resistance list).

Stop valve - straight through with butt weld ends and bellows seal (Cast steel, High temperature steel)

Figure	Nominal pressure	Material	Nominal diameter
36.140...30	PN63	1.0619+N	DN65-100
37.140...30	PN100	1.0619+N	DN65-100
38.140...30	PN160	1.0619+N	DN65-100

86.140...89	PN63	1.7357	DN65-100
87.140...89	PN100	1.7357	DN65-100
88.140...89	PN160	1.7357	DN65-100

Smaller nominal diameters refer to page 4.

Butt weld ends according to DIN EN 12627 (refer to page 6)

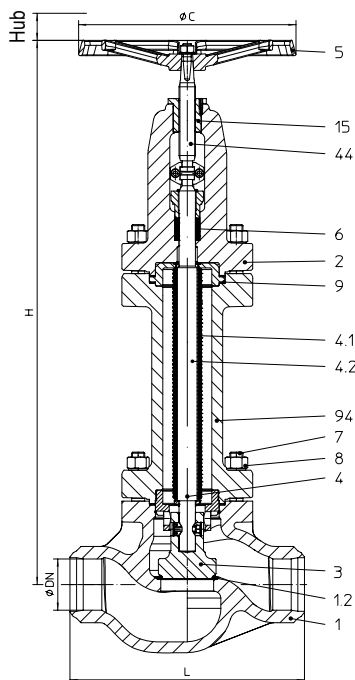
At high differential pressures a balancing plug is necessary! (refer to page 8)

Parts				
Pos.	Sp. p.	Description	Fig. 36./37./38.140...30	Fig. 86./87./88.140...89
1		Body	GP240GH+N, 1.0619+N	G17CrMo5-5, 1.7357
1.2		Seat	Stellit 21	
2	x (unit)	Bonnet	GP240GH+N, 1.0619+N	G17CrMo5-5, 1.7357
3		Plug	X20Cr13+QT, 1.4021+QT (hardened)	13CrMo4-5, 1.7335 / Stellit 6
4		Spindle unit		
4.1		Bellows seal	X6CrNiMoTi17-12-2, 1.4571	
4.2		Stem	X6CrNiMoTi17-12-2, 1.4571	
6		Packing ring	Pure graphite	
15		Insert nuts	CuZn35Ni3Mn2AlPb, CW710R	
44		Stem, top	X39CrMo17-1+QT, 1.4122+QT	
94		Bellows housing	GP240GH+N, 1.0619+N	G17CrMo5-5, 1.7357
5			Handwheel	EN-GJS-400-15, EN-JS1030 (FE 13 epoxy-coating)
7		Stud-bolt	21CrMoV 5-7, 1.7709	
8		Hexagon nut	21CrMoV 5-7, 1.7709	
9	x	Gasket	Pure graphite 99,85% (with Cr-Ni-grooved)	
	L Spare parts			

DN	65	80	100
----	----	----	-----

Face-to-face dimension ETE serie 65 acc. to DIN EN 12982			
L	(mm)	340	380

Dimensions			
H	(mm)	843	924
ØC	(mm)	400	400
Hub	(mm)	27	32
Kvs-value	(m³/h)	78	122
Zeta-value	--	4,7	4,4

Zeta-value ... range of tolerance for Kvs-values acc. to VDI/VDE 2173

Seat tightness: Leakage rate A acc. to DIN EN 12266-1

Weights			
36./37./38.140 86./87./88.140	(kg)	79,4	120
			149

Information / restriction of technical rules need to be observed!

Operating and installation instructions can be downloaded at www.ari-armaturen.com.

A production permission acc. to TRB 801 No. 45 is available.

The engineer, designing a system or a plant, is responsible for the selection of the correct valve.

Resistance and fitness must be verified, contact manufacturer for information (refer to Product overview and Resistance list).



DN	10	15	20	25	32	40	50	65	80	100
----	----	----	----	----	----	----	----	----	----	-----

Standard-flange dimensions			Flanges according to DIN EN 1092-1 Form B1									
PN63	ØD	(mm)	100	105	130	140	155	170	180	205	215	250
	ØK	(mm)	70	75	90	100	110	125	135	160	170	200
	n x Ød	(mm)	4 x 14	4 x 14	4 x 18	4 x 18	4 x 22	4 x 22	4 x 22	8 x 22	8 x 22	8 x 26
PN100	ØD	(mm)	100	105	130	140	155	170	195	220	230	265
	ØK	(mm)	70	75	90	100	110	125	145	170	180	210
	n x Ød	(mm)	4 x 14	4 x 14	4 x 18	4 x 18	4 x 22	4 x 22	4 x 26	8 x 26	8 x 26	8 x 30
PN160	ØD	(mm)	100	105	130	140	155	170	195	220	230	265
	ØK	(mm)	70	75	90	100	110	125	145	170	180	210
	n x Ød	(mm)	4 x 14	4 x 14	4 x 18	4 x 18	4 x 22	4 x 22	4 x 26	8 x 26	8 x 26	8 x 30

Valves with butt weld ends

Edge shaping acc. to DIN EN 25817

Ød3 / s1 = corresponding pipe dimension

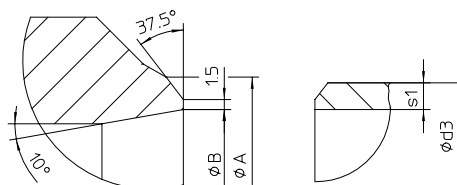

DN	10	15	20	25	32	40	50	65	80	100
----	----	----	----	----	----	----	----	----	----	-----

Butt weld ends according to DIN EN 12627

L	(mm)	150	150	150	160	180	210	250	340	380	430	
PN63	ØA	(mm)	18	22	28	35	44	50	62	77	117	
	ØB	(mm)	13,2	17,3	22,3	28,5	37,2	43,1	53,9	68,9	80,9	104,3
	Ød3	(mm)	17,2	21,3	2	33,7	42,4	48,3	60,3	76,1	88,9	114,3
	s1	(mm)	2	2	2,3	2,6	2,6	2,6	3,2	3,6	4	5
PN100	ØA	(mm)	18	22	28	35	44	50	62	77	117	
	ØB	(mm)	13,2	17,3	22,3	28,5	37,2	43,1	53,9	68,9	80,9	104,3
	Ød3	(mm)	17,2	21,3	26,9	33,7	42,4	48,3	60,3	76,1	88,9	114,3
	s1	(mm)	2	2	2,3	2,6	2,6	2,6	3,2	3,6	4	5
PN160	ØA	(mm)	18	22	28	35	44	50	62	77	117	
	ØB	(mm)	13,2	17,3	22,3	27,3	35,2	41,1	52,3	64,9	76,3	98,3
	Ød3	(mm)	17,2	21,3	26,9	33,7	42,4	48,3	60,3	76,1	88,9	114,3
	s1	(mm)	2	2	2,3	3,2	3,6	3,6	4	5,6	6,3	8

Face-to-face dimension ETE serie 65 nach DIN EN 12982.

The material used for ARI valves with butt weld ends are:

- P250GH, 1.0460 acc. to DIN EN 10222-2
- 16Mo3, 1.5415 acc. to DIN EN 10222-2
- 13CrMo4-5, 1.7335 acc. to DIN EN 10222-2
- GP240GH+N, 1.0619+N acc. to DIN EN 10213
- G17CrMo5-5, 1.7357 acc. to DIN EN 10213

Pressure-temperature-ratings Intermediate values for max. permissible operational pressures can be determined by linear interpolation of the given temperature / pressure chart.

acc. to manufacturers standard			-10°C to 50°C	100°C	150 °C	200°C	250°C	300°C	350°C	400°C
1.0619+N	PN 63	(bar)	63	59	56	53	48	44	41	38
	PN 100	(bar)	100	93	88	83	76	69	64	60
	PN 160	(bar)	160	149	141	133	122	110	103	95

acc. to manufacturers standard			-10°C to 50°C	120°C	150°C	200°C	250°C	300°C	350°C	400°C	450°C
1.0460	PN 63	(bar)	63	63	58	50	45	40	36	32	24
	PN 100	(bar)	100	100	90	80	70	60	56	50	38
	PN 160	(bar)	160	160	145	130	112	96	90	80	60

acc. to manufacturers standard			-10°C to 250°C	300°C	350°C	400°C	450°C	500°C	520°C	530°C
1.5415	PN 63	(bar)	63	56	50	47	45	29	16	14
	PN 100	(bar)	100	87	78	74	70	45	27	22
	PN 160	(bar)	160	139	125	118	112	72	43	35
1.7335	PN 63	(bar)	63	63	61	58	56	47	32	25
	PN 100	(bar)	100	100	95	91	87	74	49	38
	PN 160	(bar)	160	160	153	146	139	118	79	62
1.7357	PN 63	(bar)	63	63	60	57	53	41	28	23
	PN 100	(bar)	100	100	95	90	84	65	45	37
	PN 160	(bar)	160	160	152	144	135	104	72	59

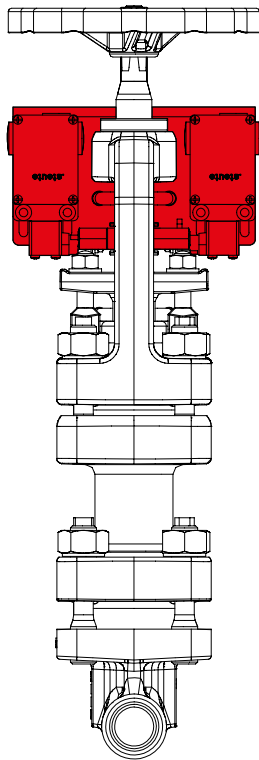

Limit switch, mechanic
(special limit switches on request)

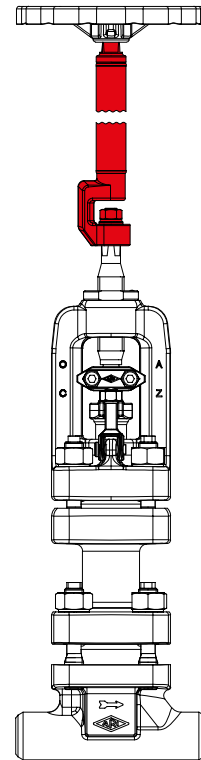

Stem extension
(please specify height in your order! Max. 2500mm)

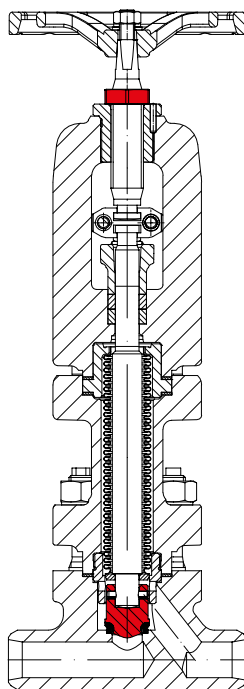

Regulating plug with lock nut as locking device
(for max. permissible ΔP refer to: Flow diagram)

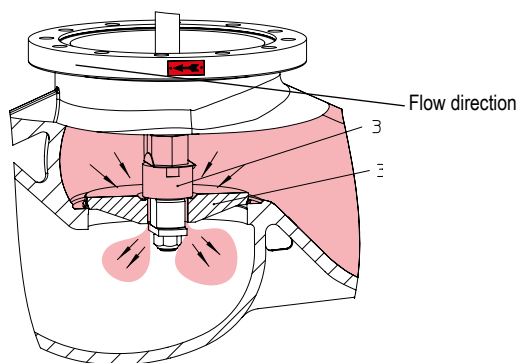

Balancing plug

Valves with balancing plugs have to be installed with medium flowing over the plug (3) as indicated by flow direction arrow on valve body.

Working principles:

When the valve is closed, anticlockwise rotation of the hand wheel lifts the pilot plug (3.1) off the larger balancing plug (3).

This allows the medium to pass through the plug and equalizes the pressure of the medium under the plug (3). After the pressures have been equalized within the values stated in the table, the valve can be opened by turning the valve further with normal manual force.

Balancing plugs are fully effective only in closed systems.

The pressures of the medium on either side of the plug can not be equalized if the medium is discharged into open air.

A bypass line or some other arrangement is necessary if too much time is required for pressure equalization owing to the volume in the piping system..

ARI-stop valves with differential pressures exceeding the following pressures, have to be fitted with pressure balancing plugs

DN		65	80	100
Gauge press. (ΔP)	(bar)	110	70	44

Please indicate when ordering:

- Figure-No.
- Nominal pressure
- Nominal diameter
- Body material
- Special design / accessories

Example:

Figure 46.146....40; Nominal pressure PN63; Nominal diameter DN15; Body material 1.0460; Regulating plug with locking device.

Figure 88.140....80; Nominal pressure PN160; Nominal diameter DN25; Body material 1.5415.