

ALL POSITIONS CAST IRON CHECK VALVE PN16



ISO 9001
BUREAU VERITAS
Certification



Size : DN 50 to 300
Ends : Flanged ISO PN16
Min Temperature : - 10°C
Max Temperature : + 110°C
Max Pressure : 16 Bars
Specifications : Stainless steel disc
All positions

Materials : Cast iron body

ALL POSITIONS CAST IRON CHECK VALVE PN16

SPECIFICATIONS :

- All positions
- Respect the flow direction indicated by the arrow
- Flanged R.F. ISO PN16
- Stainless steel disc with spring
- Epoxy blue RAL 003 painting 80 microns thickness

USE :

- Water distribution
- Min Temperature Ts : - 10°C
- Max Temperature Ts : + 110°C
- Max Pressure PN : 16 bars

RANGE :

- Flanged ISO PN16 DN50 to DN300 **Ref.369**
- Flanged ISO PN16 from DN50 to DN250 with steel strainer basket **Ref.368** (Ref.369+367)

MATERIALS :

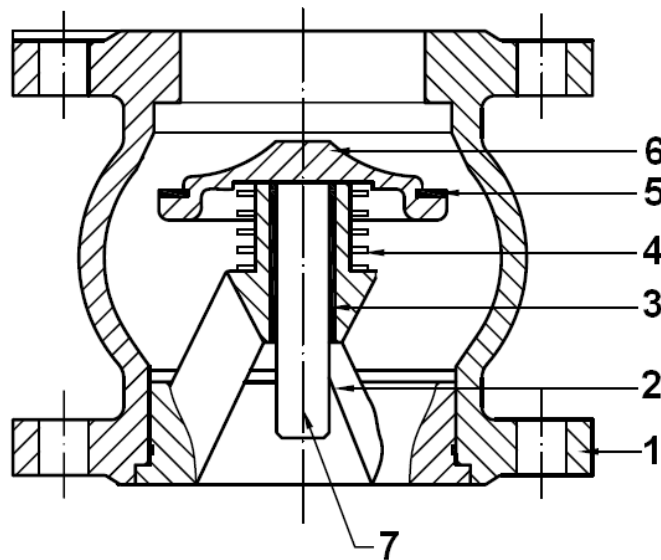

Item	Designation	Materials
1	Body	Cast iron EN-GJL-250
2	Guide	Cast iron EN-GJL-250
3	Bushing	Bronze
4	Spring	SS 304
5	Gasket	EPDM
6	Disc	SS 304
7	Shaft	SS 416

ALL POSITIONS CAST IRON CHECK VALVE PN16

SIZE REF. 369 (in mm):

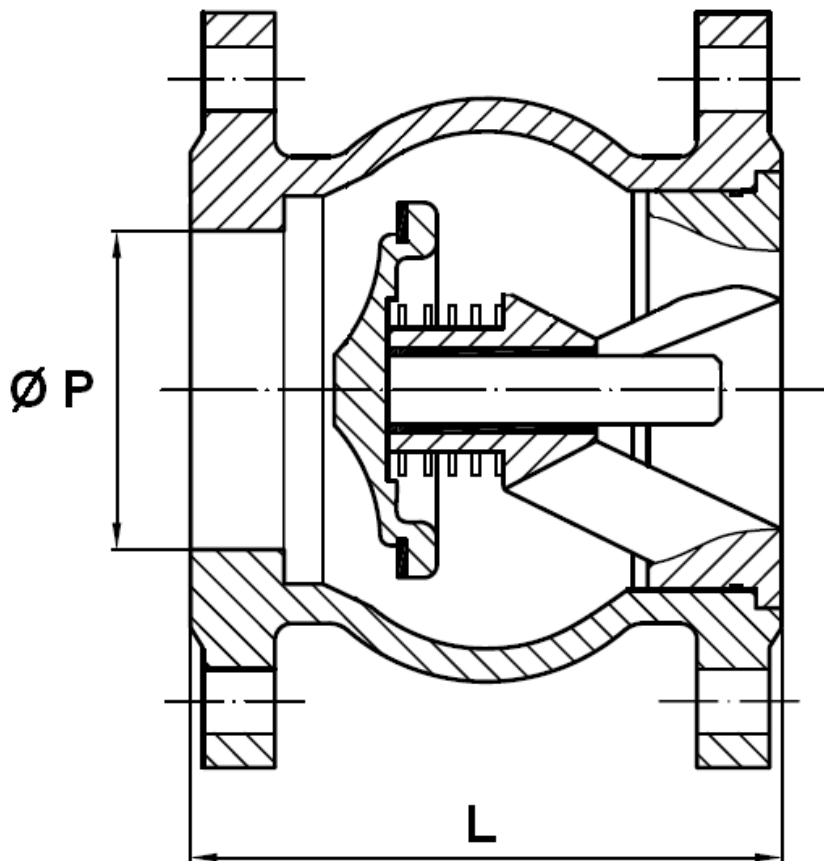

	DN	50	65	80	100	125	150	200	250	300
Ref. 369	Ø P	56	65	81	105	125	150	200	250	300
	L	100	120	135	165	200	231	288	354	395
	Weight (Kg)	6	9	11	15.5	23.5	34.5	56.5	97.5	145.5

ALL POSITIONS CAST IRON CHECK VALVE PN16

SIZE REF. 368 (in mm):

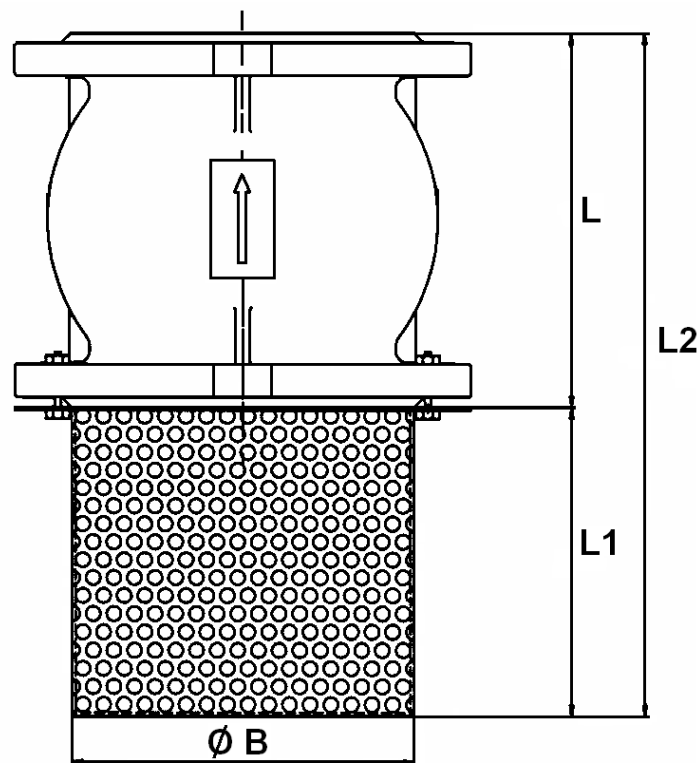

REF.	DN	50	65	80	100	125	150	200	250
368	L	100	120	135	165	200	231	288	354
	L1	77	110	125	155	170	220	300	390
	L2	177	230	260	320	370	451	588	744
	Ø B	93	113	128	148	178	200	255	310
	Mesh	6	6	6	6	6	6	6	6
	Weight (Kg)	6.59	9.76	11.83	16.7	24.99	36.3	59.28	101.88

Sferaco 90 rue du Ruisseau 38297 St Quentin Fallavier Tel: + 33 (0) 474.94.15.90 Fax: + 33 (0) 474.95.62.08 Internet: www.sferaco.fr E-mail : sferaco@sferaco.fr

Date : 08/11

Page 4 sur 5

Rev. 01

Information provided as an indication and subject to possible modification

ALL POSITIONS CAST IRON CHECK VALVE PN16

STANDARDS :

- Fabrication according to ISO 9001 : 2000
- DIRECTIVE 97/23/CE : Concerned by article 3, § 3
- Flanged R.F. according to EN 1092-1 PN16

ADVICE : Our opinion and our advice are not guaranteed and SFERACO shall not be liable for the consequences of damages. The customer must check the right choice of the products with the real service conditions.

INSTALLATION INSTRUCTIONS

GENERAL GUIDELINES :

- Ensure that the check valves to be used are appropriate for the conditions of the installation (type of fluid, pressure and temperature).
- Be sure to have enough valves to be able to isolate the sections of piping as well as the appropriate equipment for maintenance and repair.
- Ensure that the valves to be installed are of correct strength to be able to support the capacity of their usage.

INSTALLATION INSTRUCTIONS :

- **Before installing the check valves, clean and remove any objects from the pipes** (in particular bits of sealing and metal) which could obstruct and block the valves.
- **Ensure that both connecting pipes either side of the check valve (upstream and downstream) are aligned (if they're not, the valves may not work correctly).**
- **Make sure that the two sections of the pipe (upstream and downstream) match, the check valve unit will not absorb any gaps. Any distortions in the pipes may affect the tightness of the connection, the working of the check valve and can even cause a rupture.** To be sure, place the kit in position to ensure the assembling will work.
- **If sections of piping do not have their final support in place, they should be temporarily fixed. This is to avoid unnecessary strain on the check valve.**
- If there is a direction changing or if there's another material, it's better to take away the check valve so that it is outside the turbulence area (**between 3 and 5 times the ND before and after**).
- After a pump please refer to norm NF CR 13932 to install the check valve.