

CHECK VALVE WITH STRAINER BASKET

Ref. 311

Ref. : DS 311

Rev. :

Date : 08/06



Valves and fittings

90 rue du ruisseau 38297 ST QUENTIN FALLAVIER

Tel : (33)04.74.94.15.90 Fax : (33)04.74.95.62.08

E.mail : sferaco@sferaco.fr

USE :

- . Water distribution
- . Max température Ts : 100 °C
- . Max pressure Ps : see dimensions

RANGE :

. Ref. 311

DESIGNATION	MATERIALS
Body	Brass EN 12165
Strainer	Stainless steel 304
Gasket	NBR



SIZE :

	DN	1/2"	3/4"	1"	1"1/4	1"1/2	2"	2"1/2	3"	4"
Ref.	L	33	42	47,5	59	67,5	81	103	111	140,5
311	H	66	72	85,5	95,5	112	140	158	167	192
	Ps	10	10	10	10	8	8	8	6	6
	Weight	0,08	0,12	0,16	0,23	0,32	0,49	1,11	1,22	1,86

STANDARDS :

. DIRECTIVE 97/23/CE : Products excluded from directive (article 1, § 3.2)

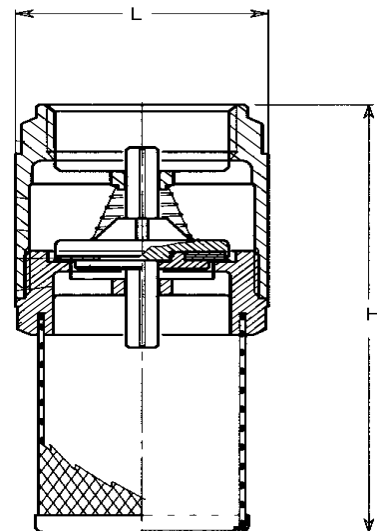

ADVICE : Our opinion and our advice are not guaranteed and SFERACO shall not be liable for the consequences of damages. The customer must check the right choice of the products with the real service conditions.