

**Maintenance-free  
Diaphragm valves  
lined  
and  
unlined**

flanged  
**PN 16**  
**DN 20 - 200**  
**ND 3/4" - 8"**

### Fields of application

- food and beverage industries
- domestic applications
- chemical and industrial process engineering
- power plants
- general industries

Suitable for drinking water, utility water, air, oil and technical gases as well as aggressive and abrasive media.

### Operating data

- operating temperature range from -20°C up to +160°C
- operating pressure range from vacuum up to 16 bar

### Design

Soft sealing valve, weir type.  
Sealing in the passage and towards the outside by a completely enclosed diaphragm with a supporting spiral spring.  
Position indicator with integrated stem protection.

### Specifications

valve	- manufactured and tested	EN 13397
	- designated	DIN/EN 19 (ISO 5209)
	- DVGW registered	DVGW-sheet W 900
flange	- dimensions	DIN 2501 (BS 4504)
		ASME B 16.5 - 1996 Cl.150
	- surface	DIN EN 1092-2 Form B(RF)
face to face length		
	- SISTO-16 S	EN 558-1 R7 (ISO 5752/7) (BS 5156)

### Inspection

certificate - material	EN 10204 2.2
	EN 10204 3.1
- final inspection	EN 10204 3.1

SISTO valves comply with the safety requirements of the Pressure Equipment Directive 97/23/EG, fluid group 1+2, modul H.  
SISTO valves have no own potential ignition source and can therefore, according to ATEX 94/9/EG, be used in hazardous locations of the group II, category 2 (zone 1+21) and category 3 (zone 2 +22)

### Materials

Body	nodular cast iron JS-1025	GJS-400-18-LT
Bonnet	nodular cast iron JS-1025	GJS-400-18-LT
Compressor	grey cast iron	JL-1030 GJL-300-15
	zinc alloy	GD-ZnAl4Cu1 2.2141
Stem	stainless steel X12CrMoS17	1.4104
Diaphragm	EPDM	+140°C
Handwheel	cast iron	JL-1030

### Variants

Body Lining	NR-H	Ebonite	+100°C
	IIR	Butyl	+120°C
	PTFE	TF1641	+160°C
	TFM	TFM1600	+160°C
Body Coating	PA-KTW	Rilsan	+90°C
	ECTFE	Halar	+90°C
Diaphragm Materials	EPDM/W 270		+90°C
	EPDM-V (Vacuum)		+140°C
	NBR		+90°C
	CSM		+100°C
	IIR		+120°C
	PTFE/EPDM 2layer		+160°C
	TFM/EPDM 2layer		+160°C

Gearbox recommended > 10 bar from DN 100

**These data are given as a guide only and do not apply to all operating conditions.**

### On all inquiries / orders please specify

- |                           |                                  |
|---------------------------|----------------------------------|
| 1 - type                  | 7 - medium                       |
| 2 - PN                    | 8 - pipe connection              |
| 3 - DN                    | 9 - variants                     |
| 4 - working pressure      | 10 - certificate                 |
| 5 - differential pressure | 11 - type series booklet- number |
| 6 - operating temperature |                                  |



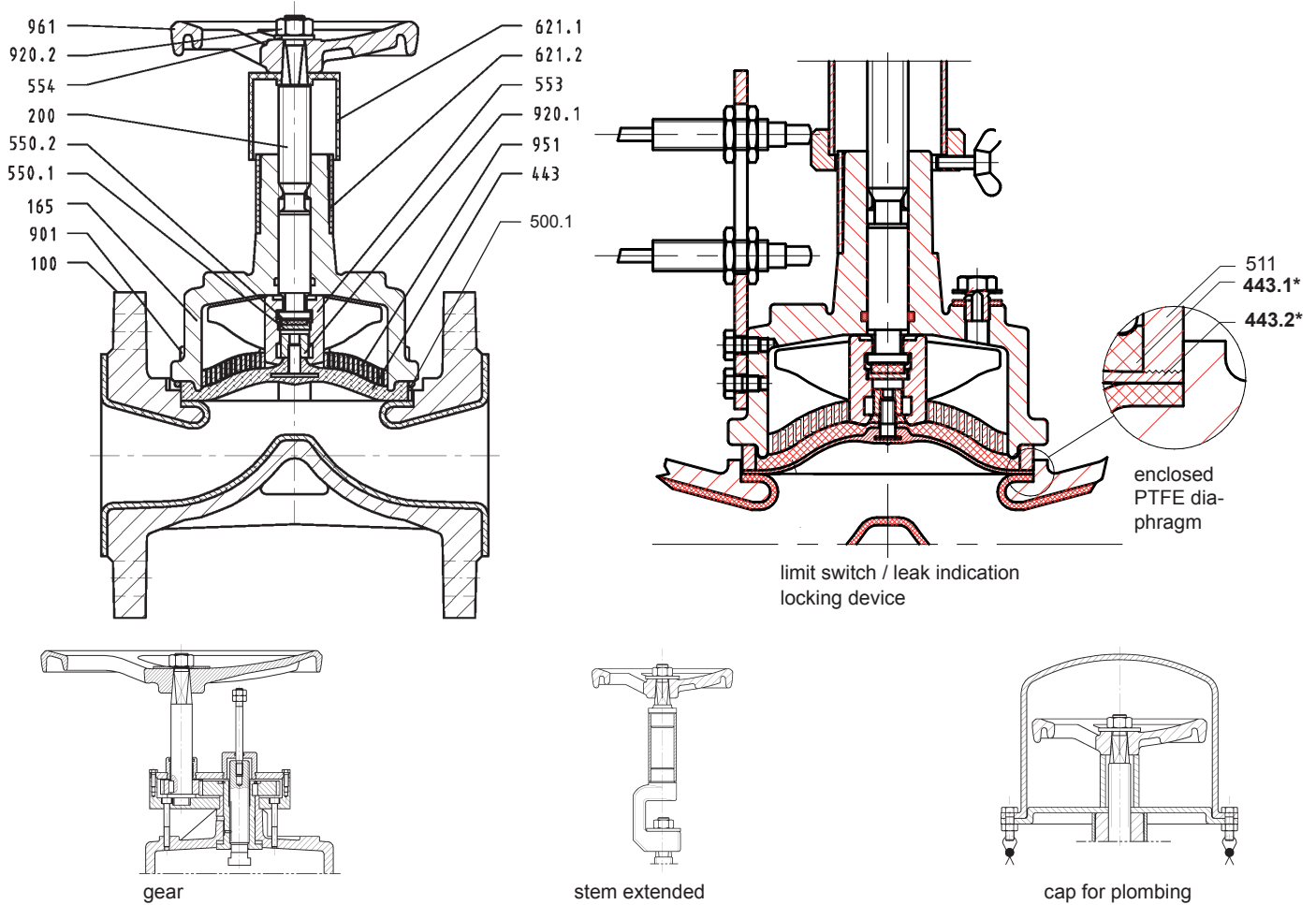

Item no.	Designation	Material	Note
100	body	JS-1025	
165	bonnet	JS-1025	
200	stem	1.4104	
443*	diaphragm	EPDM	Standard
443.1*	backing diaphragm	EPDM	
443.2*	diaphragm	PTFE	
500.1	ring	ST 37 / A2E	
511	backing ring	ST 37 / A2E	
550.1	bearing disc	9S20	on DN 040 - 200
550.2	disc	PTFE/graphite	on DN 040 - 200
553	compressor	JS-1030	GD-ZnAlCu1 on DN 020 - 032
554	disc	Al	
621.1	upper opening indicator	ABS Luran	on DN 040 - 200
621.2	lower opening indicator	ABS Luran	
901	hexagon screw	A2-70	Execution PTFE/TFM - material 8.8
920.1	nut	9S20K	
920.2	hexagon nut	A2	
951	support spiral spring	St 2K BK	
961	handwheel	JL-1030	

\*recommended spare part

Operating instructions

0570.821

material limitations

data sheet

8630.165

**max. permissible operating pressure**

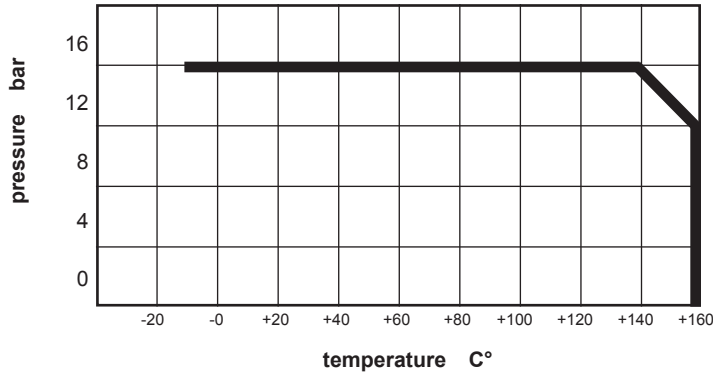

**flow values**

DN	Kv-value m³/h	DN	Kv-value m³/h
020	11,5	065	72
025	14,0	080	195
032	14,0	100	304
040	43,0	125	298
050	72,0	150	601
		200	478

There is no need to reduce the max. permissible operating pressure in relation to temperature and valve size.

The temperature limit is determined by the applied material.

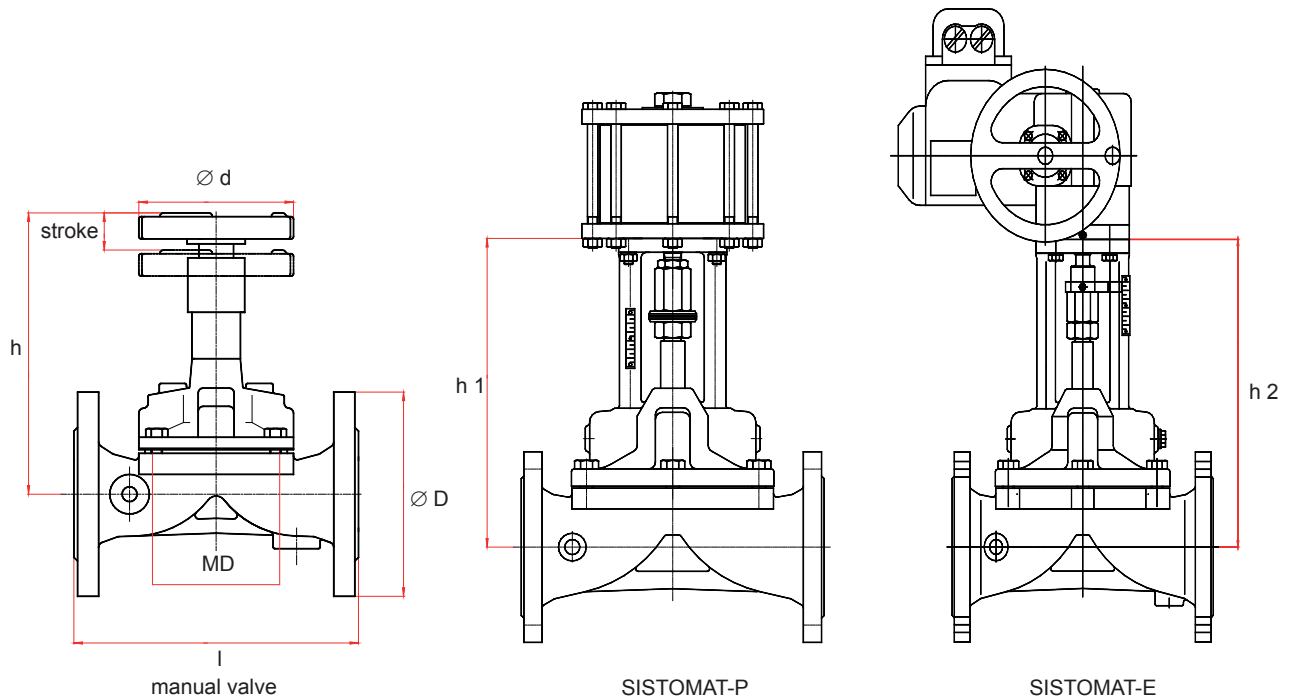

nominal size DN	diaphragm MD	face-to-face length l	stroke Ø D s	manual valves				actuated valves			
				height h*	handwheel d	handwheel turns approx.	weight kg	height MAT-P h1*	height MAT-E h2* F 07/F 10	F 14	
020	65	117**	105 13	150	100	4	3,4	210	210		
025	65	127**	115					3,8			
032	65	146**	140					5,0			
040	92	159**	150 22	192		7	7,0	230	230		
050	115	190**	165 30	231	125	8	10,5	250	250		
065	115	216**	185				12,5				
080	168	254**	200 45	322	200(250)***	9	21,5	305	320		
100	202	305**	220 60	388	250	12	35,0	355	370		
125	202	356**	250		(315)***		40,0				
150	280	406**	285 80	512	400	13	72,0	435	460	480	
200	280	521**	340		(500)***		90,0				

\*\*\*optional operating pressure > 10 bar

SISTOMAT-P  
SISTOMAT-E, MTAE/LAE  
SISTOMAT-PC

type series booklet 9210.1  
on request  
type series booklet 8635.1PC

all dimensions in mm  
\*with rubber lining add. 5 mm  
\*\*with rubber lining and lining add. 6 mm

**all moving parts**  
are separated from the  
medium by the diaphragm

**thrust bearing**  
reduces the required closing  
torques

**diaphragm support**  
increase the reliability during the  
operation, the service life and the  
pressure limit of the diaphragm

**no entrapment areas**  
only diaphragm and body are in contact  
with the medium

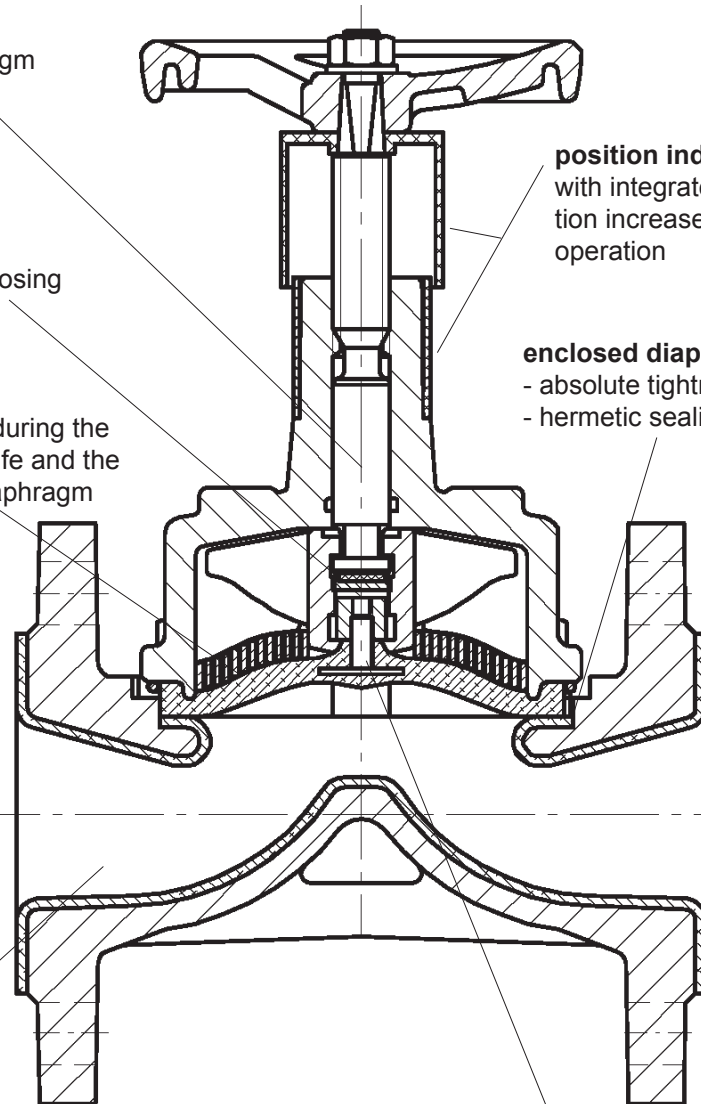

**position indicator**  
with integrated stem protec-  
tion increases the reliability of  
operation

**enclosed diaphragm guarantees**  
- absolute tightness towards the outside  
- hermetic sealing of the stem

**balanced diaphragm suspension**  
increases life time of the diaphragm

This document is not contractual and  
may be amended without notice.

8635.101/13-10 / 12.07.2011