

771XS VALVE WITH NA/NA-X ELECTRIC ACTUATOR

CHARACTERISTICS

The 771XS+ NA ball valve is dedicated to the automatic opening / shut-off of unloaded industrial fluids below a 16 bar pressure. Its compact “wafer” design enables a lighter installation compared with the traditional “flanged” design. This full bore ball valve is certified according to the ATEX and EC standards. The ISO pad 5211 enables the direct mounting of the NA electric actuator. It is perfectly adapted for an indoor or outdoor industrial use.



AVAILABLE ITEMS

1.4408 stainless steel (A351 CF8M) body
 DN 50 to DN 100
 Flanged connections RF PN16
 Voltages 24 V AC/DC, 230 V AC, 3~400 V AC

LIMITS OF USE

Max. allowable pressure (PS)	16 bar (20° C)
Min./max. allowable temperature (TS)	-30 °C / +180 °C
Room temperature	-20 °C / +70 °C
Service	S2 – 70%

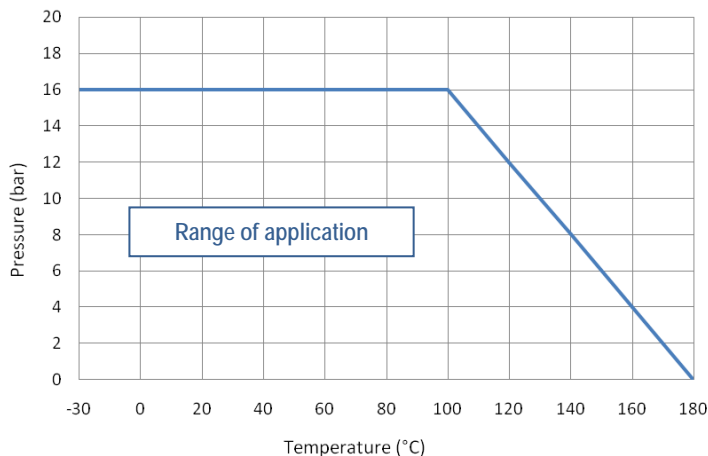

DIRECTIVES AND DEVELOPMENT STANDARDS APPLICABLE

	Standard	Notified bodies		Standard
97/23/EC Pressure Equipment Directive	DN 15 and 20 : excluded		Valve testing	EN 12266
	DN 25 to 100 : category III	TÜV #0035	Material certificate	EN 10204
Size	EN 12516-1		Actuator attachment	ISO 5211
Alloy grade	EN 1503-1			
ATEX Directive	Valve	SIRA #0518	II 2G/D Tx for zones 1,2,21 and 22	
	Actuator (NA-X option)	NEMKO #0470	II 2G EEx d II B T4 for zones 1 and 2	

The following data is for information purpose only and may be subject to alteration without prior notice

	SECTORIEL S.A. 45, rue du Ruisseau 38290 Saint Quentin-Fallavier – FRANCE Tel.: +33 474 94 90 70 – Fax: +33 474 94 13 95 www.sectoriel.fr / email: sectoriel@sectoriel.fr	Nbr. pages	1/3
		Ref.	771XS+SA GB
		Rev.	0
		Date	07/2011

771XS VALVE WITH NA/NA-X ELECTRIC ACTUATOR

CONSTRUCTION

#	Item	Material	#	Item	Material
1	Body	Stainless steel A351 CF8M/1.4408	12	Lever	Stainless steel 304
2	Flanges	Stainless steel A351 CF8M/1.4408	13	Lever nut	Stainless steel 304
3	Seats	PTFE+15% Graphite	14	End stop	Stainless steel 304
4	Ball	Stainless steel 316	15	Plastic sleeve	PVC
5	Stem	Stainless steel 316	16	Locking system	Stainless steel 304
6	Body gasket	PTFE	17	Spring	Stainless steel 316
7	Top body gasket	PTFE+15% GF	18	Antistatic device	Stainless steel 316
8	Gland packing	PTFE	19	End stop plate	Stainless steel 304
9	O-ring	FKM	20	Spacer	Stainless steel 304
10	Spacer	Stainless steel 304	21	Screw	Stainless steel 304
11	Belleville spring washer	Stainless steel 301			

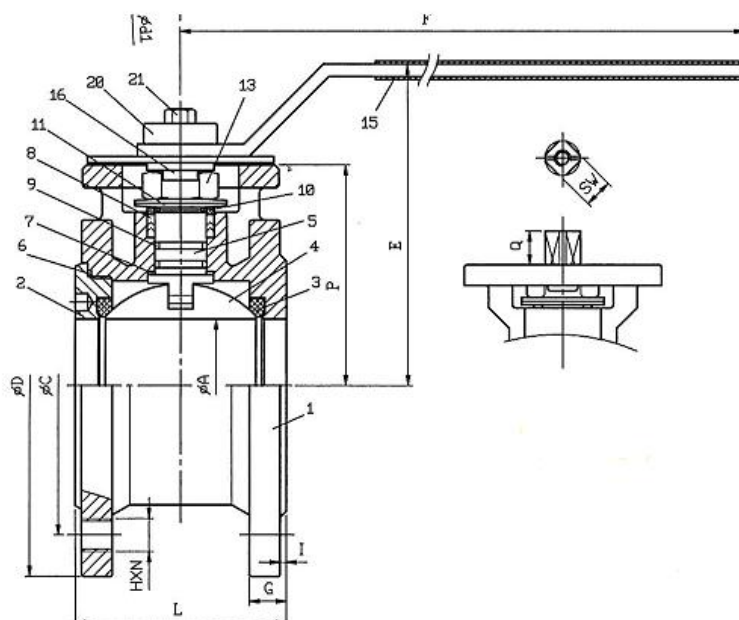

DIMENSIONS (mm)

DN	15	20	25	32	40	50	65	80	100
A	16	20	25	32	40	50	65	80	96
C	65	75	85	100	110	125	145	160	180
D	95	105	115	140	150	165	185	200	220
E	89	89	101	112	116	125	154	165	180
F	114	114	187	187	222	222	350	350	350
G	14	16	16	16	16	18	18	20	20
H x N	M12x4	M12x4	M12x4	M16x4	M16x4	M16x4	M16x4	M16x8	M16x8
L	42	44	50	54	68	82	103	122	152
I	2	2	2	2	3	3	3	3	3
P	54	56	62.5	72	78	87.2	107	117.3	132.3
Weight (kg)	1.45	1.92	2.60	3.70	4.65	6.45	10.25	13.55	19.85

The following data is for information purpose only and may be subject to alteration without prior notice

	SECTORIEL S.A. 45, rue du Ruisseau 38290 Saint Quentin-Fallavier – FRANCE Tel.: +33 474 94 90 70 – Fax: +33 474 94 13 95 www.sectoriel.fr / email: sectoriel@sectoriel.fr	Nbr. pages	2/3
		Ref.	771XS+SA GB
		Rev.	0
		Date	07/2011

771XS VALVE WITH NA/NA-X ELECTRIC ACTUATOR

ACTUATION WITH NA

Suggested standard NA actuation under the following conditions:

- Electric actuator with an IP 67 epoxy coated aluminium enclosure and steel gears
- A minimum 1.3 safety factor compared with the valve nominal torque rating,
- A maximum pressure differential up/downstream of 10 bar (=ΔP)

Direct mounting of the actuator (except for DN ¾" version with SE actuator, which is mounted with brackets in accordance with the EN 15081 standard)





DN	Actuator	Power	Operating Time*	
15	Refer to 771XS + SA electric actuator			
20				
25				
32				
40				
				Standard equipment of the actuator
50	NA09	25W	17s	2 adjustable limit switches + 2 dry auxiliary switches 20 W anti-condensation heater Visual position indicator Actuator thermal cut-out (NA09) Torque limiter (NA15) Electrical connection: 2 gland packs M20 x 1.5 Manual override by declutchable handwheel
65	NA09	25W	17s	
80	NA15	40W	20s	
100	NA15	40W	20s	

*Unloaded operating time given for information purpose only. May vary depending on the medium

For any other working conditions, please contact us.

ACTUATION OPTIONS

There are many different options, please contact our commercial department.

1	2	3	4	5
NALCU: Actuator with a local control	NAPCU: Regulation actuator 4-20 mA or 0-10 V	NARBP: Safety actuator with an integrated battery emergency shutdown	NA-X: Actuation for use in ATEX zones 1 and 2	SR: Spring return safety actuator
				
6	Thermal dispersion bracket for high temperature fluids			
7	100 mm high stem extension for pipe insulation			
8	Electric actuator sized for a maximum pressure differential up/downstream over 10 bar (=ΔP)			
9	NA electric actuator with a declutchable manual override by handwheel			

ATEX ZONES INSTALLATION

It is compulsory to specify if the installation of the automatic valve 765+NA-X will take place in ATEX zones 1 or 2 while making the order. Our services will proceed to the mounting check, to a grounding strip installation and will edit a mounting certificate. Those operations are performed by our proper engineers. Please contact us for further details. It is also compulsory to follow the ATEX zone mounting and maintenance special instructions for motorized valves. The ATEX gland packs and sealing plugs are not provided. Please use the following codes:

ATEX aluminium gland pack M20x1.5	Code 980179	ATEX aluminium sealing plugs M20x1.5	Code 980180
-----------------------------------	-------------	--------------------------------------	-------------

The following data is for information purpose only and may be subject to alteration without prior notice

	SECTORIEL S.A. 45, rue du Ruisseau 38290 Saint Quentin-Fallavier – FRANCE Tel.: +33 474 94 90 70 – Fax: +33 474 94 13 95 www.sectoriel.fr / email: sectoriel@sectoriel.fr	Nbr. pages	3/3
		Ref.	771XS+SA GB
		Rev.	0
		Date	07/2011

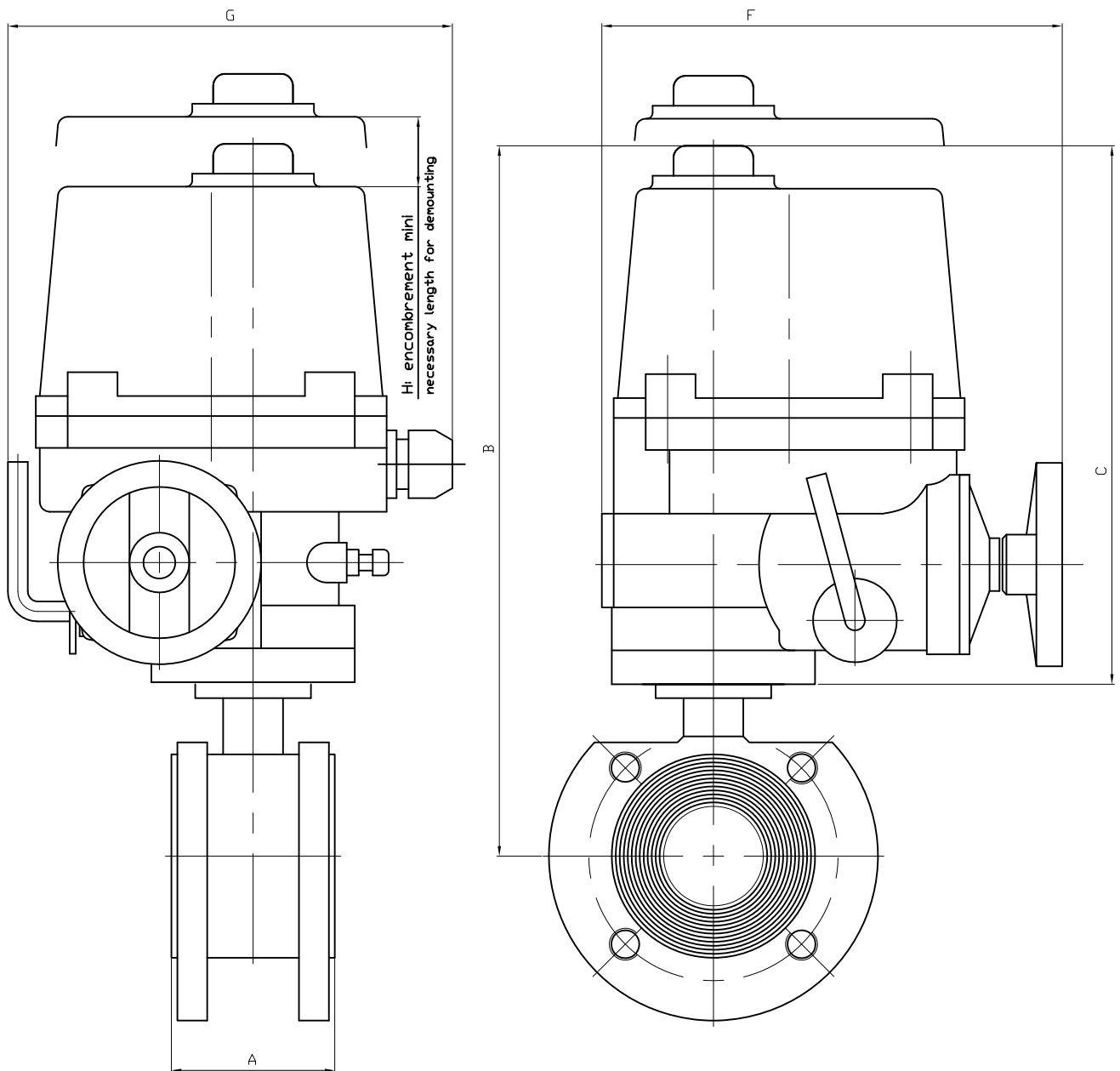

DN	50	65	80	100
TYPE	NA09	NA09	NA15	NA15
A	82	103	122	152
B	342.2	359	372.2	387.3
C	255	255	255	255
F	231	231	261	261
G	229	229	266	266
H	108	108	108	108

Informations données à titre indicatif et sous réserve de modifications éventuelles

Ech: /	Date :10/03/2011	Dessiné par : E.D.	Tolérances générales : +/- 0.2	Modifications	Date	REV.
ROBINET A TOURNANT SPHERIQUE 771XS + SERVOMOTEUR NA				Matière :		
				Poids (Kg) :		
 45, Rue du Ruisseau 38297 SAINT QUENTIN FALLAVIER				Traitement : SANS		
				Plan n° Ens 1097		

ELECTRIC ACTUATOR TYPE NA / NA-X

GENERAL CHARACTERISTICS

The NA electric actuator is dedicated to the actuation of industrial ¼ turn valve. The maximum torque value is 2500 Nm. With a compact design, an IP 67 cast aluminium enclosure and an epoxy protection, the NA electric actuator is especially adapted to the actuation of ball valves and butterfly valves in dusty outdoor or indoor areas. It is equipped with a declutchable manual override and a torque limiter (except on NA06 and NA09). Many options are available. The NA-X version can be used in explosive areas 1 and 2 and complies with the EN 15714-2 standard.

AVAILABLE MODELS

NA06: 60 Nm to NA250: 2500 Nm

Voltage: 230 V AC, 400 V AC, 24 V AC, 24 V DC

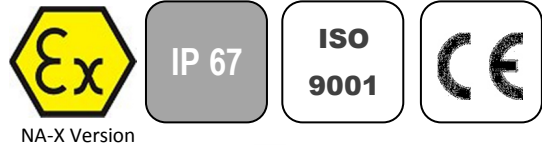

LIMITS OF USE

Version	NA	NA-X
Protection rating	IP 67	
Temperature range	-20 °C / +70 °C	-20 °C / +55 °C
Service	S2-70%	
Explosive areas	Forbidden	Zone 1 and 2



MECHANICAL CHARACTERISTICS

Gears	Treated steel pinions
Rotation angle	90° +/- 5°
Declutching	Lever
Manual override	Handwheel
Torque limiter	Except for NA06 and NA09

Electric actuator	NA06	NA09	NA15	NA28	NA38	NA60	NA100	NA150	NA200	NA250
Torque	60 Nm	90 Nm	150 Nm	280 Nm	380 Nm	600 Nm	1000 Nm	1500 Nm	2000 Nm	2500 Nm
Operating time	17 s	17 s	20 s	24 s	24 s	29 s	29 s	87 s	87 s	87 s
ISO 5211 pad	F07	F07	F07/F10	F10/F12	F10/F12	F12/F14	F12/F14	F14/F16	F14/F16	F14/F16
Star drive nut	17	17	17	22	27	27	27	36	36	46

DIRECTIVES AND DEVELOPMENT STANDARDS APPLICABLE

Machine 2006/42/EC	Actuator attachments : ISO 5211
Low Voltage Directive 2006/95/EC	Electromagnetic compatibility 2004/108/EC
ATEX 1994/9/EC: ATEX II 2 G EEx d II B T4 – NEMKO 03ATEX1342X (NA-X electric actuator only)	

The following data is for information purpose only and may be subject to alteration without prior notice

	SECTORIEL S.A. 45, rue du Ruisseau 38290 Saint Quentin-Fallavier – FRANCE Tel.: +33 474 94 90 70 – Fax: +33 474 94 13 95 www.sectoriel.fr / email: sectoriel@sectoriel.fr	Pages	1/4
		Ref.	FT23110 GB
		Rev.	5
		Date	06/2012

ELECTRIC ACTUATOR TYPE NA / NA-X

CONSTRUCTION

1	Position indicator	Polycarbonate
2	Condenser	
3	Terminal block	
4	Limit switches	
5	Body / cover	Aluminium alloy
6	Base / enclosure	Aluminium alloy
7	Drive nut	Steel
8	Dome	Polycarbonate
9	Electric motor	
10	Anti-condensation heater	
11	Handwheel	Steel
12	Manual override	Steel
13	Declutching lever	Steel
14	Worm gear	Steel

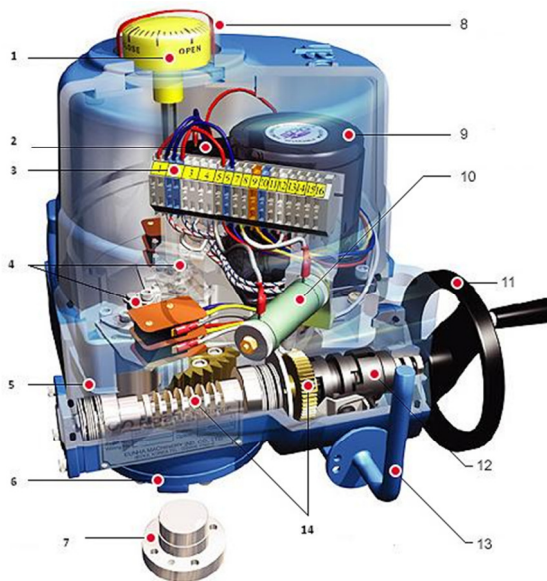

ELECTRICAL CHARACTERISTICS

Motor Protection	Thermal cut-out		Anti-condensation	20 W heater						
Limit switches	2 adjustable switches		Electrical connection	2 gland packs M20x1.5						
Auxiliary switches	2 dry adjustable switches									
Electric actuator	NA06	NA09	NA15	NA28	NA38	NA60	NA100	NA150	NA200	NA250
Power	15 W	25 W	40 W	40 W	60 W	90 W	180 W	98 W	180 W	180 W
Voltage	380 V – 50 Hz									
Hold current	0.13 A	0.18 A	0.3 A	0.3 A	0.33 A	0.52 A	0.73 A	0.52 A	0.73 A	0.73 A
Inrush current	0.23 A	0.36 A	0.59 A	0.74 A	0.78 A	1.24 A	1.68 A	0.78 A	1.68 A	1.68 A
Voltage	220 V – 50 Hz									
Hold current	0.45 A	0.58 A	0.95 A	0.95 A	1.3 A	1.5 A	2.15 A	1.5 A	2.15 A	2.15 A
Inrush current	0.63 A	0.89 A	1.12 A	1.37 A	1.85 A	2.34 A	3.4 A	2.34 A	3.4 A	3.4 A
Voltage	24 V – 50 Hz									
Hold current	3.2 A	4.3 A	6.5 A	8.1 A						
Inrush current	6 A	8 A	12 A	14 A						
Voltage	24 V DC									
Hold current	2.2 A	3.5 A	4.5 A	6.5 A						
Inrush current	4.1 A	4.1 A	6.6 A	13.8 A						

The following data is for information purpose only and may be subject to alteration without prior notice

	SECTORIEL S.A. 45, rue du Ruisseau 38290 Saint Quentin-Fallavier – FRANCE Tel.: +33 474 94 90 70 – Fax: +33 474 94 13 95 www.sectoriel.fr / email: sectoriel@sectoriel.fr	Pages	2/4
		Ref.	FT23110 GB
		Rev.	5
		Date	06/2012

ELECTRIC ACTUATOR TYPE NA / NA-X

DIMENSIONS (mm)

NA06 to NA100

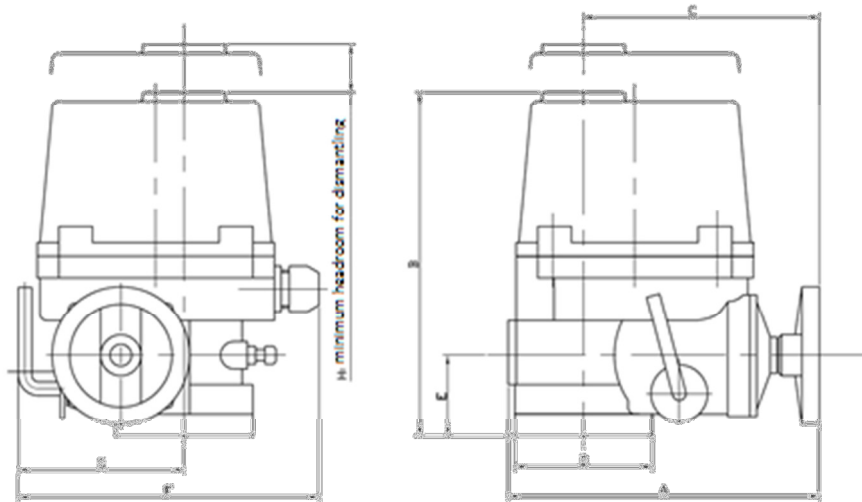

NA150 to NA250

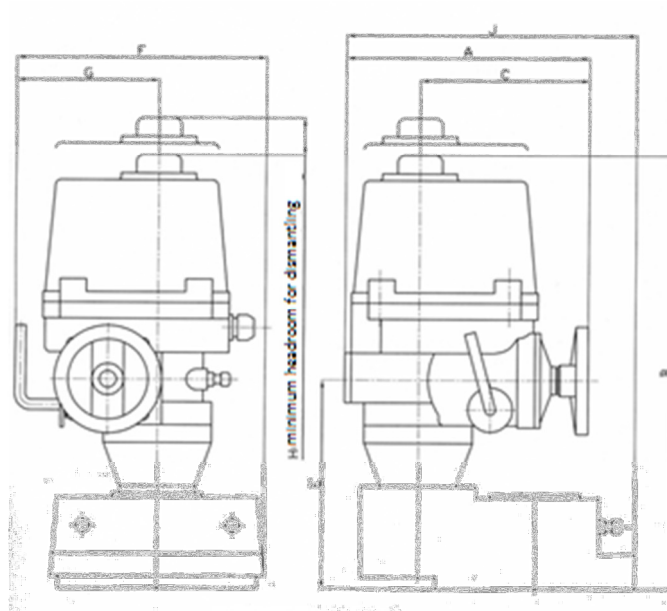

NA	A	B	C	D	E	F	G	H
NA06 - NA09	231	255	175	102	60	223	113	108
NA15	261	255	184	120	60	266	139	108
NA28 - NA38	285	302	202	145	70	300	159	130
NA60 - NA100	325	343	226	175	78	349	191	178
NA150 - NA200 - NA250	325	556	226	-	273	388	191	178

The following data is for information purpose only and may be subject to alteration without prior notice

	SECTORIEL S.A. 45, rue du Ruisseau 38290 Saint Quentin-Fallavier – FRANCE Tel.: +33 474 94 90 70 – Fax: +33 474 94 13 95 www.sectoriel.fr / email: sectoriel@sectoriel.fr	Pages	3/4
		Ref.	FT23110 GB
		Rev.	5
		Date	06/2012

ELECTRIC ACTUATOR TYPE NA / NA-X

OPTIONS

1	NAPIU : feedback potentiometer version
2	NACPT: 4-20 mA position transmitter version
3	NAPCU: 0-10, 2-10 V, 2-20 mA, 4-20 mA regulation card version
4	NALCU: local control version
5	NARBP: integrated battery emergency shutdown device version
6	Earthquake simulation test
7	Low temperature version (-40 °C)
8	IP 68 version
9	Rotation angles 120°, 135°, 180°, 270°

The following data is for information purpose only and may be subject to alteration without prior notice

	SECTORIEL S.A. 45, rue du Ruisseau 38290 Saint Quentin-Fallavier – FRANCE Tel.: +33 474 94 90 70 – Fax: +33 474 94 13 95 www.sectoriel.fr / email: sectoriel@sectoriel.fr	Pages	4/4
		Ref.	FT23110 GB
		Rev.	5
		Date	06/2012