

3 PIECES BALL VALVE FLANGED GN40 Ref. 765

Ref. : DS 765

Rev. : 8

Date : 12/07

Page 1/1



Valves and fittings

90 rue du ruisseau 38297 ST QUENTIN FALLAVIER
Tel:(33)04.74.94.15.90 Fax:(33)04.74.95.62.08
E.mail : sferaco@sferaco.fr

SPECIFICATIONS :

- . Full bore
- . Anti-blow out stem
- . ISO direct mounting
- . Locking device handle
- . Carbon PTFE seats for high temperature

USE :

- . For all common fluids
- . Max. temperature Ts : 180°C to Ps 0
- . Max. pressure Ps : 40 bars to 20°C
- . Steam : 10 bars Maximum

RANGE :

- . Flanged GN40 carbon steel **Ref. 765** DN15 to DN100

MATERIALS :

DESIGNATION	MATERIALS
Body	A 216 WCB
End	A 216 WCB
Ball	Stainless steel 304
Stem	Stainless steel 304
Seat	PTFE reinforced carbon
Packing	PTFE reinforced carbon
Gasket	PTFE reinforced carbon
Nut	Steel
Handle	Stainless steel 304

STANDARDS :

- . DIRECTIVE 97/23/CE : CE N° 0035
- . Risk category II
- . Lenght according to DIN 3202 F1



SIZE :

DN	15	20	25	32	40	50	65	80	100
Ref. 765									
L	130	150	160	180	200	230	290	310	350
H	73	80,8	90,5	98,7	115,3	124	155	208,5	216,7
E	112	112	136	185	197,9	198	264	264	325
B	8,5	8,5	11,4	11,4	14	13,7	18	18	23
C	9	9	9	9	14	14	17	17	17
K	50	50	50	50	70	70	102	102	102
ISO	F05	F05	F05	F05	F07	F07	F10	F10	F10
K1	36	36	36	36	50	50	70	70	70
ISO	F03	F03	F03	F03	F05	F05	F07	F07	F07
Weig.	2,04	2,9	3,66	5,4	6,76	9,75	15,36	21,33	36,06

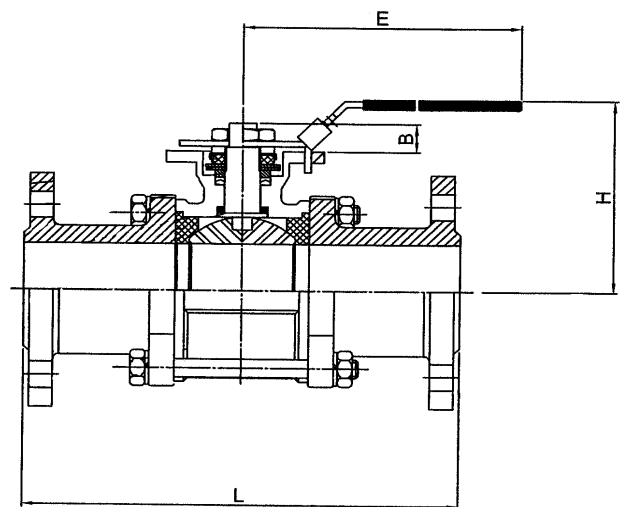
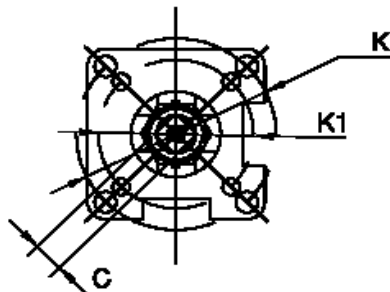

ADVICE : Our opinion and our advice are not guaranteed and SFERACO shall not be liable for the consequences of damages. The customer must check the right choice of the products with the real service conditions.