

FIRE SAFE BALL VALVE ISO PN16/40 FLANGED



Size : DN 15 to 200 mm
Ends : ISO PN16/40 Flanges
Min Temperature : -50°C in SS and -20°C in carbon steel
Max Temperature : + 250°C
Max Pressure : 40 Bars up to DN50, 16 Bars over
Specifications : ISO 5211 mounting pad
Fire safe according to ISO 10497 : 2004
Fugitive emissions according to EN 15848-1 : 2006
Atex

Materials : Carbon steel or stainless steel

FIRE SAFE BALL VALVE ISO PN16/40 FLANGED

SPECIFICATIONS :

- Full bore
- Anti blow-out stem
- Pure PTFE TFM1600 seat (PMD FF)
- Locking device
- ISO 5211 mounting pad
- 2 pieces type (Split body)
- ISO PN40 Flanges R.F. up to DN50, ISO PN16 over
- Antistatic device
- Fire safe ISO 10497 : 2004
- Fugitive emissions EN 15848-1 : 2006
- Graphite packing + FKM O ring on stem
- With exhaust hole in the ball (located in the top of the ball to avoid overpressure in it)
- Black painting colour RAL 9004 , 5-15 microns thickness for carbon steel type (Ref. 752)

USE :

- For all common fluids
- Min and max Temperature Ts : -50°C to + 250°C for stainless steel type **Ref. 753**
- Min and max Temperature Ts : -20°C to + 250°C for carbon steel type **Ref. 752**
- Max Pressure PN : 40 bars up to DN50, 16 bars over (see graph)

PRESSURE / TEMPERATURE GRAPH (STEAM EXCLUDED) FOR CARBON STEEL TYPE REF.752 :

PRESSURE

REF. 752

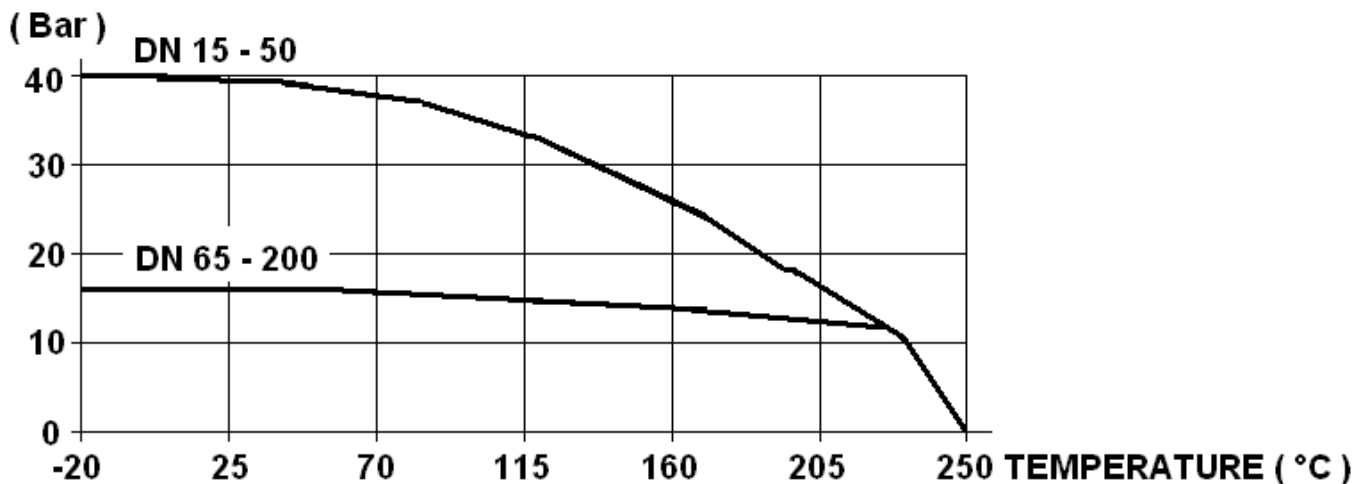

FIRE SAFE BALL VALVE ISO PN16/40 FLANGED

PRESSURE / TEMPERATURE GRAPH (STEAM EXCLUDED)FOR STAINLESS STEEL TYPE REF.753 :

PRESSURE

REF. 753

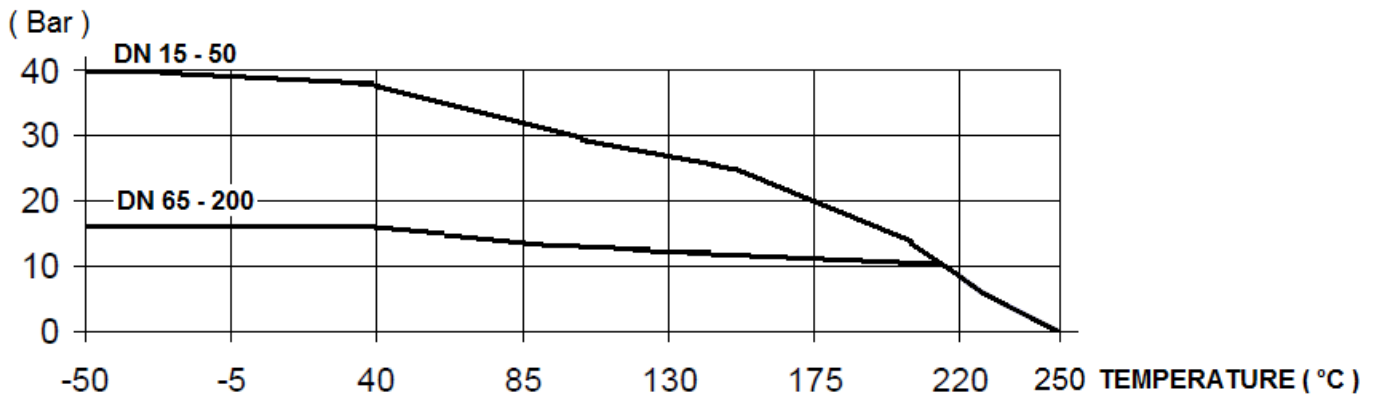

RANGE :

- Carbon steel body **Ref. 752** DN 15 to DN 200
- Stainless steel body **Ref. 753** DN 15 to DN 200
- Possible with gearbox **Ref. 9830266-267** from DN 150 to DN 200

ENDS:

- ISO PN40 Flanges R.F. up to DN50, ISO PN16 over

FIRE SAFE BALL VALVE ISO PN16/40 FLANGED

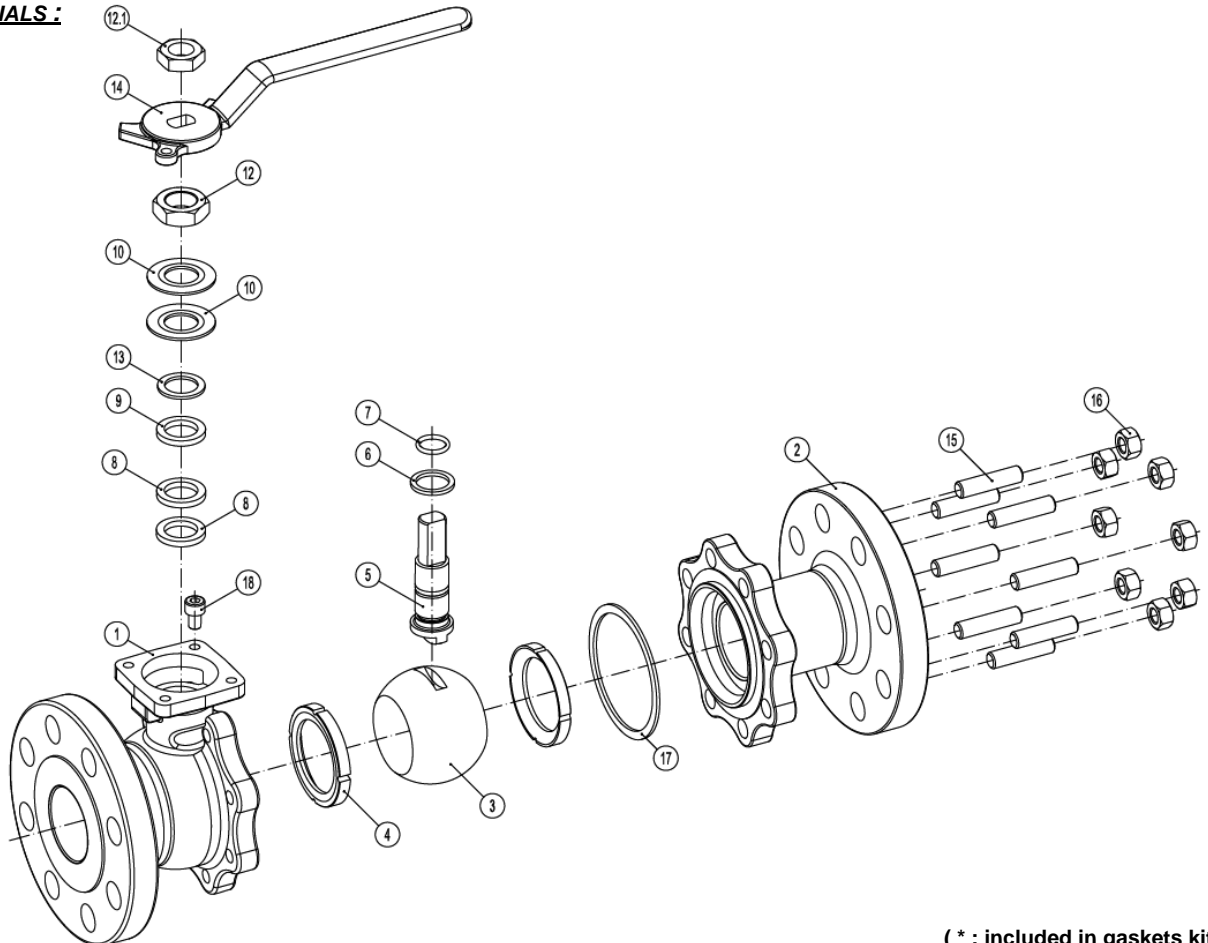
VALVE MATERIALS :

(* : included in gaskets kit)

Item	Designation	Materials 752	Materials 753
1	Body	Carbon steel ASTM A216WCB	SS ASTM A351 CF8M
2	Ends	Carbon steel ASTM A216WCB	SS ASTM A351 CF8M
3	Ball	SS ASTM A351 CF8M	
4*	Seat	Pure PTFE TFM 1600 (PMD FF)	
5	Stem	ASTM A479 type 316	
6*	Stem thrust seal	PTFE filled with 25% glass	
7*	Stem O ring	FKM	
8*	Gland Packing	Graphite	
9	Gland	SS 303	
10	Elastic ring	SS 303	
12	Gland nut	SS 303	
12.1	Handle nut	SS 303	
13*	Antifriction washer	PTFE filled with 25% glass	
14	Handle	Nodular iron	
15	Stud	A 193 Gr. B7M	A 193 Gr. B8M
16	Nut	A 194 Gr. 2HM	A 194 Gr. 8M
17*	Spiralwound gasket	SS 316L + PTFE + Graphite	
18	Bolt	A2	
19	Identification plate	Stainless steel	

FIRE SAFE BALL VALVE ISO PN16/40 FLANGED

GEARBOX MATERIALS :

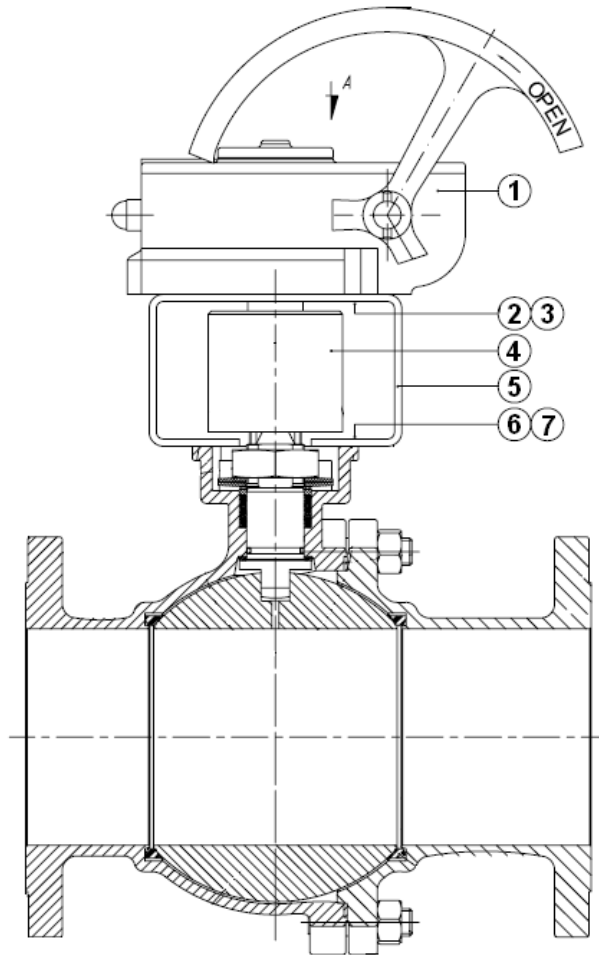

Item	Designation	Materials
1	Gearbox	Painted steel
2	Screw	DIN 912 A2
3	Washer	DIN 912 A2
4	Coupling	Stainless steel
5	Mounting bracket	Stainless steel
6	Screw	DIN 912 A2
7	Washer	DIN 912 A2

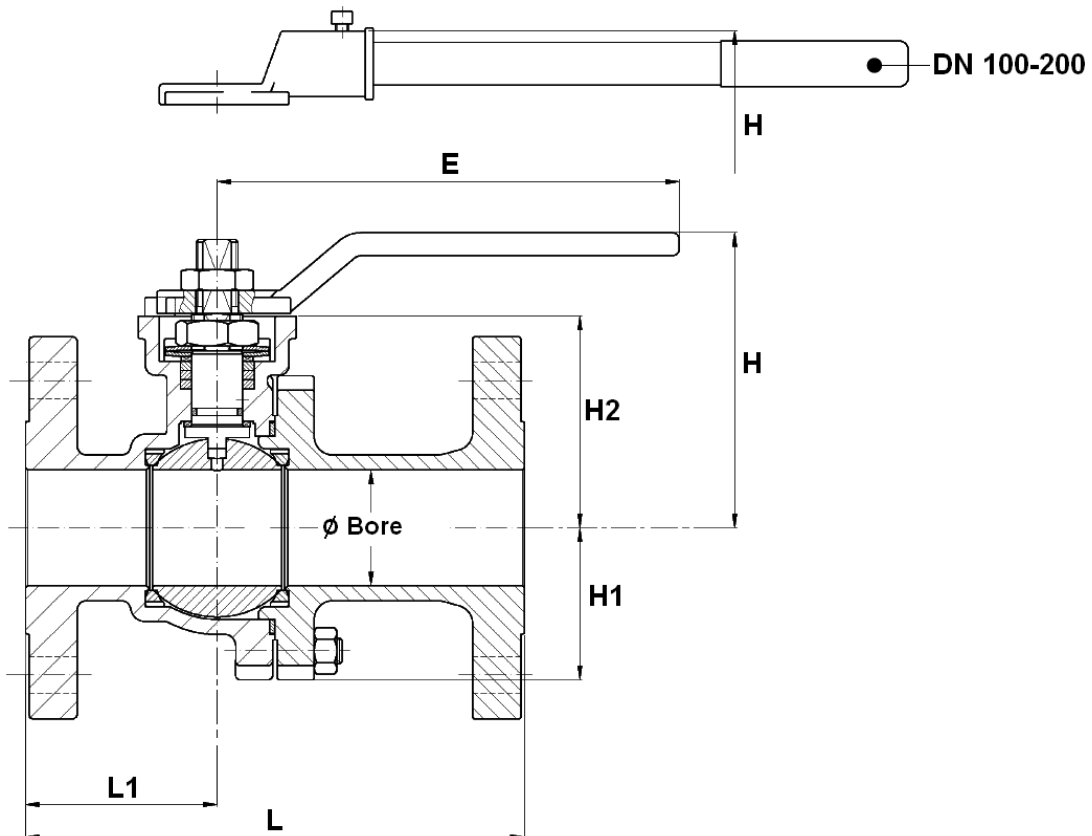
FIRE SAFE BALL VALVE ISO PN16/40 FLANGED
VALVE SIZE (in mm) :

Ref.	DN	15	20	25	32	40	50	65	80	100	125	150	200
752 / 753	Ø Bore	15	20	25	32	40	50	65	78	100	125	151	203
	L	115	120	125	130	140	150	170	180	190	325	350	400
	L1	53	52	52	54	55	61	72	73	83	120	135	200
	E	170	170	170	170	215	215	350	450	466	775	775	845
	H	68	70	86	89.5	122.5	127.5	140	190	192.5	240	259	319
	H1	31	33	39	43	48	63	78	87	108	134	152	202
	H2	41	43	58.5	63.5	86.5	91.5	104	118.5	144	184	203	250
	Weight (Kg)	2.4	3.2	4.1	5.8	8.1	10.6	13.3	19.1	25.6	47.6	63.5	115.3

FIRE SAFE BALL VALVE ISO PN16/40 FLANGED

ISO MOUNTING PAD AND STEM SIZE (in mm) :

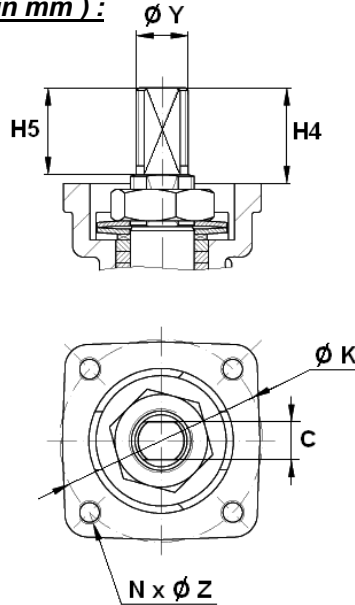

Ref.	DN	15	20	25	32	40	50	65	80	100	125	150	200
752 / 753	H4	18	18	22	22	33	33	34	34	45	56	56	69
	H5	11	11	21	21	32	32	33	33	43.5	54.5	54.5	67
	C	7	7	8	8	12	12	15	15	19	24	24	32
	ϕY	M10	M10	M12	M12	M18	M18	M22	M22	M28	M36	M36	M48
	ϕK	50	50	50	50	70	70	70	102	102	125	125	140
	ISO	F05	F05	F05	F05	F07	F07	F07	F10	F10	F12	F12	F14
	$N \times \phi Z$	4 x M6	4 x M6	4 x M6	4 x M6	4 x M8	4 x M8	4 x M8	4 x M10	4 x M10	4 x M12	4 x M12	4 x M16

FLANGES SIZE (in mm) :

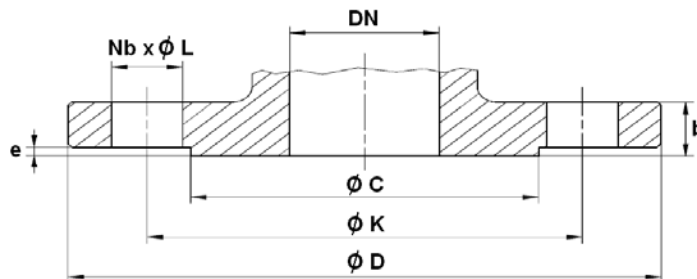

Ref.	DN	15	20	25	32	40	50	65	80	100	125	150	200
752 / 753	ϕC	45	58	68	78	88	102	122	138	158	188	212	268
	ϕD	95	105	115	140	150	165	185	200	220	250	285	340
	ϕK	65	75	85	100	110	125	145	160	180	210	240	295
	$Nb \times \phi L$	4 x 14	4 x 14	4 x 14	4 x 18	4 x 18	4 x 18	4 x 18	8 x 18	8 x 18	8 x 18	8 x 22	12 x 22
	b	16	18	18	18	18	20	18	20	20	22	22	23
	e	2	2	2	2	2	2	2	2	2	2	2	2

FIRE SAFE BALL VALVE ISO PN16/40 FLANGED

GEARBOX SIZE (in mm) :

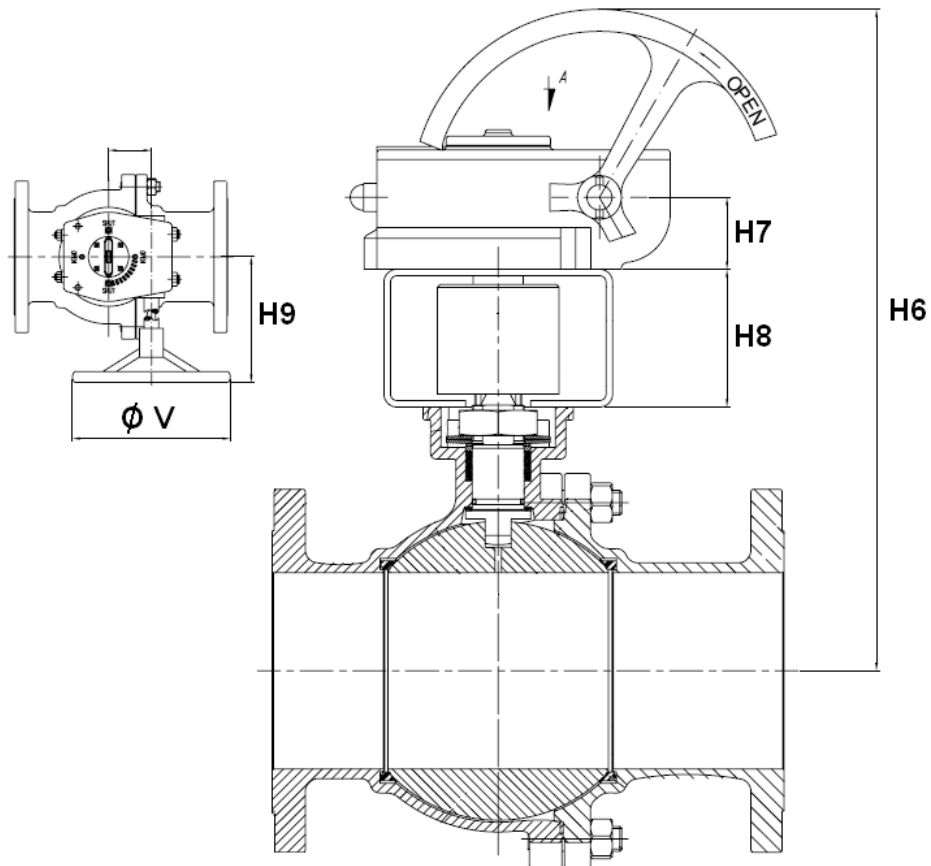

Ref.	DN	150	200
9830266-267	H6	596.5	643.5
	H7	55	55
	H8	106	106
	H9	229	229
	Ø V	465	465
	Weight gearbox (Kg)	19.5	19.7
	Weight gearbox + valve (Kg)	83	135

FIRE SAFE BALL VALVE ISO PN16/40 FLANGED

FLOW COEFFICIENT Kv (in m³ / h) :

DN	15	20	25	32	40	50	65	80	100	125	150	200
Kv (m ³ / h)	20	40	75	130	170	270	550	1000	1650	3000	4200	9000

TORQUE VALUE (in Nm without safety coefficient) :

DN	15	20	25	32	40	50	65	80	100	125	150	200
Torque (Nm)	8	12	14	22	27	50	51	77	116	159	215	493

STANDARDS :

- Fabrication according to ISO 9001:2000
- DIRECTIVE 97/23/CE : CE N° 0062
Risk Category III module H
- Valve designing according to EN 1983 – ISO 17292
- Materials according to NACE MR 01-75
- Tests according to EN 12266-1, range A
- Marking according to EN 19
- Fire safe according to ISO 10497 : 2004
- Fugitive Emissions according to EN 15848-1 : 2006
- Flanges R.F. according to EN 1092-1 PN16/40
- ISO 5211 mounting pad and stem size according to EN 15081
- Length according to EN 558-1 serie 27 (DIN 3202 F4/F5)
- ATEX Group II Category 2 G/2Dc Zone 1 & 21 Zone 2 & 22 (optional marking)

ADVICE : Our opinion and our advice are not guaranteed and SFERACO shall not be liable for the consequences of damages. The customer must check the right choice of the products with the real service conditions.

FIRE SAFE BALL VALVE ISO PN16/40 FLANGED

INSTALLATION INSTRUCTIONS

GENERAL GUIDELINES :

- Ensure that the valves to be used are appropriate for the conditions of the installation (type of fluid, pressure and temperature).
- Be sure to have enough valves to be able to isolate the sections of piping as well as the appropriate equipment for maintenance and repair.
- Ensure that the valves to be installed are of correct strength to be able to support the capacity of their usage.
- **Installation of all circuits should ensure that their function can be automatically tested on a regular basis (at least two times a year).**

INSTALLATION INSTRUCTIONS :

- **Before installing the valves, clean and remove any objects from the pipes** (in particular bits of sealing and metal) which could obstruct and block the valves.
- **Ensure that both connecting pipes either side of the valve (upstream and downstream) are aligned (if they're not, the valves may not work correctly).**
- **Make sure that the two sections of the pipe (upstream and downstream) match, the valve unit will not absorb any gaps. Any distortions in the pipes may affect the tightness of the connection, the working of the valve and can even cause a rupture.** To be sure, place the kit in position to ensure the assembling will work.
- **If sections of piping do not have their final support in place, they should be temporarily fixed. This is to avoid unnecessary strain on the valve.**
- Tighten the bolts in cross.
- It's recommended to operate the valve (open and close) 1 to 2 times per year