

Free of maintenance stop valve with bellows seal - metallic sealing

ARI-FABA®-Supra I
ARI-FABA®-Supra C
Straight through with flanges

- EN ISO 15848-1 / TA - Luft
TÜV-Test-No. TA 07 2016 C04
- TRB 801 Annex II No. 45

Cast steel
Forged steel
Stainless steel

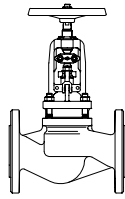

Fig. 146

Page 2-7

ARI-FABA®-Supra I
ARI-FABA®-Supra C
Straight through with butt weld ends

- EN ISO 15848-1 / TA - Luft
TÜV-Test-No. TA 07 2016 C04
- TRB 801 Annex II No. 45

Forged steel

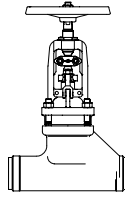

Fig. 140

Page 8-9

ARI-FABA®-Supra I
ARI-FABA®-Supra C
Straight through with butt weld ends

- EN ISO 15848-1 / TA - Luft
TÜV-Test-No. TA 07 2016 C04
- TRB 801 Annex II No. 45

Cast steel

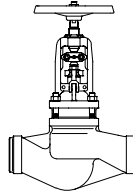

Fig. 140

Page 10-11

ARI-FABA®-Supra I
ARI-FABA®-Supra C
Y-pattern with flanges

- EN ISO 15848-1 / TA - Luft
TÜV-Test-No. TA 07 2016 C04
- TRB 801 Annex II No. 45

Stainless steel

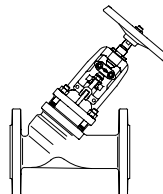

Fig. 169

Page 12-13

ARI-FABA®-Supra I
ARI-FABA®-Supra C
Y-pattern with butt weld ends

- EN ISO 15848-1 / TA - Luft
TÜV-Test-No. TA 07 2016 C04
- TRB 801 Annex II No. 45

Cast steel
Stainless steel

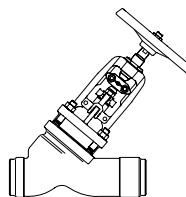

Fig. 166

Page 14-17

ARI-FABA®-Supra I
ARI-FABA®-Supra C
Angle pattern with flanges

- EN ISO 15848-1 / TA - Luft
TÜV-Test-No. TA 07 2016 C04
- TRB 801 Annex II No. 45

Cast steel

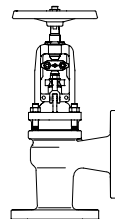

Fig. 147

Page 18-19

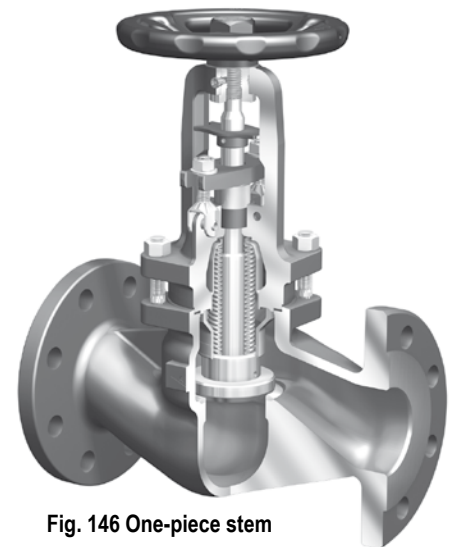

Fig. 146 One-piece stem

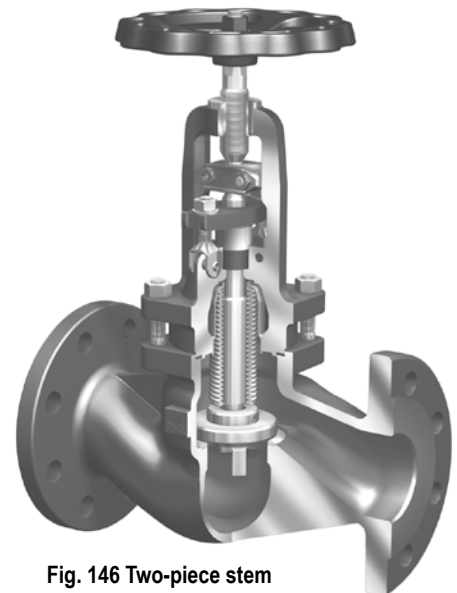

Fig. 146 Two-piece stem

For ANSI versions
refer to data sheet
„ARI-FABA®-Plus/-Supra ANSI“

Features:

- Double wall bellows seal as standard
- Bellows seal welded to bonnet
- Bellows seal 10.000 load cycles
- Industrial version: Bellows seal shielded
- Chemical version: Bellows seal flushed
- Stem back seal
- Yoke gasket, double chambered
- Plug with marginal seat
- Welded seat
- External stem thread
- Actuator retrofitting
- Secondary sealing: gland packing (with bridge)
- Stem with roll hardened thread

Stop valve - straight through with flanges and bellows seal - Industrial version (Cast steel)

Fig. 146....111 DN15-150
One-piece stem

Fig. 146....112 DN15-150
Two-piece stem

Figure-No.	Nominal pressure	Material	Nominal diameter
34.146....111	PN25	1.0619+N	DN200-400
35.146....111	PN40	1.0619+N	DN15-400
34.146....112	PN25	1.0619+N	DN200-400
35.146....112	PN40	1.0619+N	DN15-400

Test: • EN ISO 15848-1 / TA - Luft TÜV-Test-No. TA 07 2016 C04

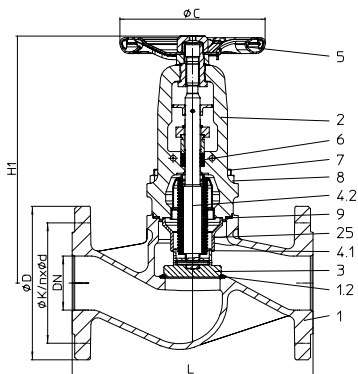
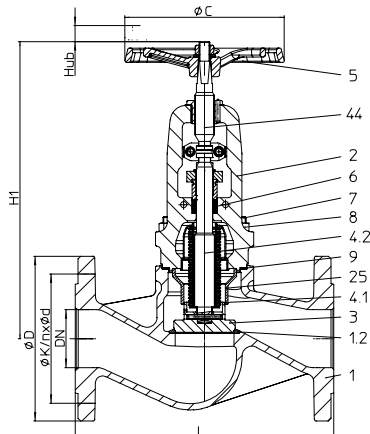
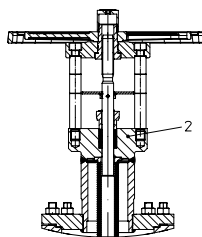
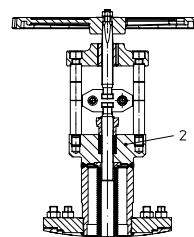
Considered standards: • EN 13709 (1.0619+N)

Plug design: • Plug with marginal seat standard

At high differential pressures a balancing plug is necessary! (refer to page 21)

Bonnet DN200-400
One-piece stem

Bonnet DN200-400
Two-piece stem

Parts				Fig. 34. / 35.146....111 One-piece stem	Fig. 34. / 35.146....112 Two-piece stem
1		Body		GP240GH+N, 1.0619+N	
1.2		Seat		G19 9 NbSi, 1.4551	
2	x (Bonnet, cpl.)	Bonnet		≤DN150: GP240GH+N, 1.0619+N / ≥DN200: P250 GH, 1.0460; P235GH-TC1, 1.0345; P265 GH, 1.0425	
+ 4.1		Bellows seal		X6CrNiMoTi17 12 2, 1.4571	
+ 4.2		Stem		X6CrNiMoTi17 12 2, 1.4571	
+ 6		Packing ring		Pure graphite	
+ 44		Stem, top		--	X39CrMo17-1+QT, 1.4122+QT
3	x	Plug		≤DN150: X20Cr13+QT, 1.4021+QT (hardened) / ≥DN200: P265GH, 1.0425 / Stellite 21	
5		Handwheel		≤DN125: St (cataphoretic coating) / ≥DN150: EN-GJS-400-15, EN-JS1030 (epoxy-coating)	EN-GJS-400-15, EN-JS1030 (epoxy-coating)
7		Stud		25CrMo4, 1.7218	
8		Hexagon nut		C35E, 1.1181	
9	x	Gasket		Pure graphite (with CrNi-grooved)	
25		Guide bush		≤DN32: X6CrNiMoTi17 12 2, 1.4571 / ≥DN40: GX5CrNiMo19-11-2, 1.4408	
L Spare parts					

DN	15	20	25	32	40	50	65	80	100	125	150	200	250	300	350	400
----	----	----	----	----	----	----	----	----	-----	-----	-----	-----	-----	-----	-----	-----

Face-to-face dimension FTF series 1 acc. to DIN EN 558													Standard-flange dimensions refer to page 25				
L	(mm)	130	150	160	180	200	230	290	310	350	400	480	600	730	850	980	1100

Dimensions																	
H1 (One-piece stem)	(mm)	225	225	230	230	270	275	300	380	460	500	570	785	940	1025	1210	1270
H1 (Two-piece stem)	(mm)	240	240	240	240	290	295	335	395	505	550	605	810	940	1025	1180	1245
ØC (One-piece stem)	(mm)	125	125	125	125	150	150	175	225	300	300	400	520	520	520	640	640
ØC (Two-piece stem)	(mm)	140	140	140	140	160	160	180	225	300	300	400	520	520	520	640	640
Travel	(mm)	6	6	8	8	13	13	16	20	25	32	40	50	70	80	90	100
Kvs-value	(m³/h)	4,7	6,4	11	15,5	28	42,5	75	105	170	270	405	675	1090	1460	2010	2640
Zeta-value	--	3,7	6,2	5,2	7	5,2	5,5	5,1	5,9	5,5	5,3	4,9	5,6	5,2	6,1	5,9	5,9

Zeta-value ... range of tolerance for Kvs-values acc. to VDI/VDE 2173

Weights																	
34.146	(kg)	--	--	--	--	--	--	--	--	--	--	--	194	296	426	642	894
35.146	(kg)	4,7	5,7	7	8,1	11,6	14,2	21,9	32,3	47,6	70,6	95	245	330	458	693	953

Information / restriction of technical rules need to be observed!

 Operating and installation instructions can be downloaded at www.ari-armaturen.com.

A production allowance acc. to TRB 801 No. 45 exists

The engineer, designing a system or a plant, is responsible for the selection of the correct valve.

Resistance and fitness must be verified (contact manufacturer for information, refer to Product overview and Resistance list).

Stop valve - straight through with flanges and bellows seal - Chemical version (Cast steel)

**Fig. 146....153 DN15-150
One-piece stem**

**Fig. 146....154 DN15-150
Two-piece stem**

Figure-No.	Nominal pressure	Material	Nominal diameter
34.146....153	PN25	1.0619+N	DN200-400
35.146....153	PN40	1.0619+N	DN15-400
34.146....154	PN25	1.0619+N	DN200-400
35.146....154	PN40	1.0619+N	DN15-400

Test: • EN ISO 15848-1 / TA - Luft TÜV-Test-No. TA 07 2016 C04

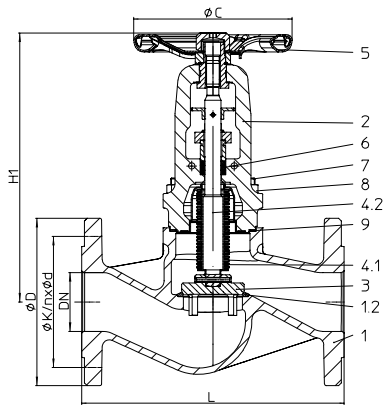
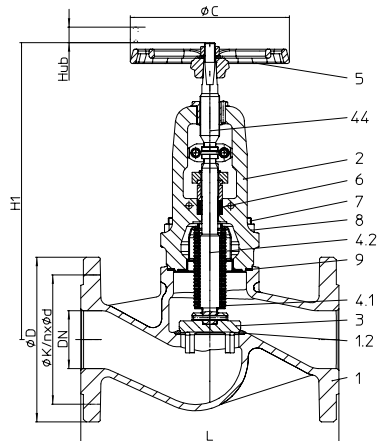
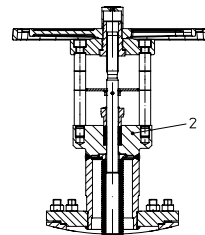
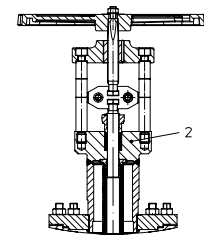
Considered standards: • EN 13709 (1.0619+N)

Plug design: • V-port plug with marginal seat standard

At high differential pressures a balancing plug is necessary! (refer to page 21)

**Bonnet DN200-400
One-piece stem**

**Bonnet DN200-400
Two-piece stem**

Parts				Fig. 34. / 35.146....153 One-piece stem	Fig. 34. / 35.146....154 Two-piece stem
Pos.	Sp.p.	Description			
1		Body	GP240GH+N, 1.0619+N		
1.2		Seat	G19 9 NbSi, 1.4551		
2	x (Bonnet, opt.)	Bonnet	≤DN150: GP240GH+N, 1.0619+N / ≥DN200: P250 GH, 1.0460; P235GH-TC1, 1.0345; P265 GH, 1.0425		
+ 4.1		Bellows seal	X6CrNiMoTi17 12 2, 1.4571		
+ 4.2		Stem	X6CrNiMoTi17 12 2, 1.4571		
+ 6		Packing ring	Pure graphite		
+ 44		Stem, top	--	X39CrMo17-1+QT, 1.4122+QT	
3	x	Plug	≤DN150: X20Cr13+QT, 1.4021+QT (hardened) / ≥DN200: P265GH, 1.0425 / Stellite 21		
5		Handwheel	≤DN125: St (cataphoretic coating) / ≥DN150: EN-GJS-400-15, EN-JS1030 (epoxy-coating)		EN-GJS-400-15, EN-JS1030 (epoxy-coating)
7		Stud	25CrMo4, 1.7218		
8		Hexagon nut	C35E, 1.1181		
9	x	Gasket	Pure graphite (with CrNi-grooved)		
L Spare parts					

DN	15	20	25	32	40	50	65	80	100	125	150	200	250	300	350	400
----	----	----	----	----	----	----	----	----	-----	-----	-----	-----	-----	-----	-----	-----

Face-to-face dimension FTF series 1 acc. to DIN EN 558																	Standard-flange dimensions refer to page 25			
L	(mm)	130	150	160	180	200	230	290	310	350	400	480	600	730	850	980	1100			

Dimensions																	
H1 (One-piece stem)	(mm)	225	225	230	230	270	275	300	380	460	500	570	785	940	1025	1210	1270
H1 (Two-piece stem)	(mm)	240	240	240	240	290	295	335	395	505	550	605	810	940	1025	1180	1245
ØC (One-piece stem)	(mm)	125	125	125	125	150	150	175	225	300	300	400	520	520	520	640	640
ØC (Two-piece stem)	(mm)	140	140	140	140	160	160	180	225	300	300	400	520	520	520	640	640
Travel	(mm)	6	6	8	8	13	13	16	20	25	32	40	50	70	80	90	100
Kvs-value	(m³/h)	4,4	6	10	13,3	25,5	38,5	64	90	135	215	325	580	885	1290	1708	2080
Zeta-value	--	4,2	7,1	6,2	9,5	6,3	6,7	7	8,1	8,8	8,4	7,7	7,6	8	7,8	8,3	9,4

Zeta-value ... range of tolerance for Kvs-values acc. to VDI/VDE 2173

Weights																	
34.146	(kg)	--	--	--	--	--	--	--	--	--	--	--	194	296	426	642	894
35.146	(kg)	4,7	5,7	7	8,1	11,6	14,2	21,9	32,3	47,6	70,6	95	245	330	458	693	953

Information / restriction of technical rules need to be observed!

 Operating and installation instructions can be downloaded at www.ari-armaturen.com.

A production allowance acc. to TRB 801 No. 45 exists

The engineer, designing a system or a plant, is responsible for the selection of the correct valve.

Resistance and fitness must be verified (contact manufacturer for information, refer to Product overview and Resistance list).

Stop valve - straight through with flanges and bellows seal - Industrial version (Forged steel)

Fig. 146....111 DN40-50
One-piece stem

Fig. 146....112 DN40-50
Two-piece stem

Figure-No.	Nominal pressure	Material	Nominal diameter
45.146....111	PN40	1.0460	DN15-50
45.146....112	PN40	1.0460	DN15-50
DN >50 refer to Fig. 35.146 (1.0619+N)			

Test:	• EN ISO 15848-1 / TA - Luft TÜV-Test-No. TA 07 2016 C04
-------	--

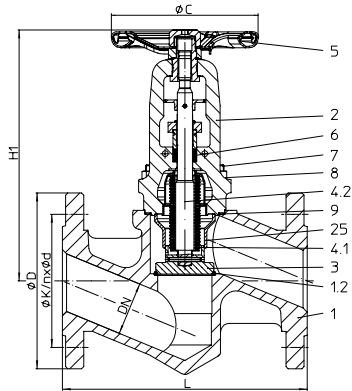
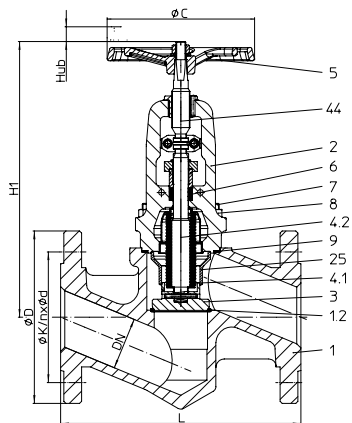
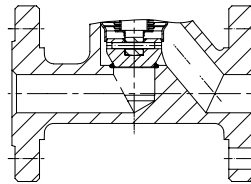
Considered standards:	• EN 13709 (1.0460)
-----------------------	---------------------

Plug design:	• Plug with marginal seat standard
--------------	------------------------------------

Body DN15-32

Parts				
Pos.	Sp.p.	Description	Fig. 45.146....111 One-piece stem	Fig. 45.146....112 Two-piece stem
1		Body	P250 GH, 1.0460	
1.2		Seat	G19 9 NbSi, 1.4551	
2	x (Bonnet, cpl.)	Bonnet	GP240GH+N, 1.0619+N	
+ 4.1		Bellows seal	X6CrNiMoTi17 12 2, 1.4571	
+ 4.2		Stem	X6CrNiMoTi17 12 2, 1.4571	
+ 6		Packing ring	Pure graphite	
+ 44		Stem, top	--	X39CrMo17-1+QT, 1.4122+QT
3	x	Plug	X20Cr13+QT, 1.4021+QT (hardened)	
5	x	Handwheel	St (cataphoretic coating)	EN-GJS-400-15, EN-JS1030 (epoxy-coating)
7		Stud	25CrMo4, 1.7218	
8		Hexagon nut	C35E, 1.1181	
9	x	Gasket	Pure graphite (with CrNi-grooved)	
25		Guide bush	≤DN32: X6CrNiMoTi17 12 2, 1.4571 / ≥DN40: GX5CrNiMo19-11-2, 1.4408	
L Spare parts				

DN	15	20	25	32	40	50
----	----	----	----	----	----	----

Face-to-face dimension FTF series 1 acc. to DIN EN 558		Standard-flange dimensions refer to page 25					
L	(mm)	130	150	160	180	200	230

Dimensions							
H1 (One-piece stem)	(mm)	235	235	245	250	275	275
H1 (Two-piece stem)	(mm)	250	250	255	260	295	295
ØC (One-piece stem)	(mm)	125	125	125	125	150	150
ØC (Two-piece stem)	(mm)	140	140	140	140	160	160
Travel	(mm)	6	6	8	8	13	13
Kvs-value	(m³/h)	3,4	6	9,5	12,5	21	31
Zeta-value	--	7	7,1	6,9	10,7	9,3	10,4
Zeta-value ... range of tolerance for Kvs-values acc. to VDI/VDE 2173							

Weights							
45.146	(kg)	4,4	5,4	6,3	7,8	11	13,5

Information / restriction of technical rules need to be observed!

Operating and installation instructions can be downloaded at www.ari-armaturen.com.

A production allowance acc. to TRB 801 No. 45 exists

The engineer, designing a system or a plant, is responsible for the selection of the correct valve.

Resistance and fitness must be verified (contact manufacturer for information, refer to Product overview and Resistance list).

Stop valve - straight through with flanges and bellows seal - Chemical version (Forged steel)

Fig. 146....153 DN40-50
One-piece stem

Fig. 146....154 DN40-50
Two-piece stem

Figure-No.	Nominal pressure	Material	Nominal diameter
45.146....153	PN40	1.0460	DN15-50
45.146....154	PN40	1.0460	DN15-50
DN >50 refer to Fig. 35.146 (1.0619+N)			
Test:	• EN ISO 15848-1 / TA - Luft TÜV-Test-No. TA 07 2016 C04		
Considered standards:	• EN 13709 (1.0460)		
Plug design:	V-port plug with marginal seat standard		

Body DN15-32

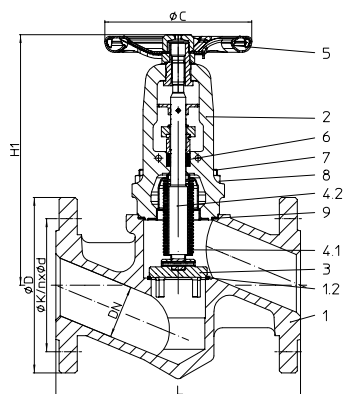
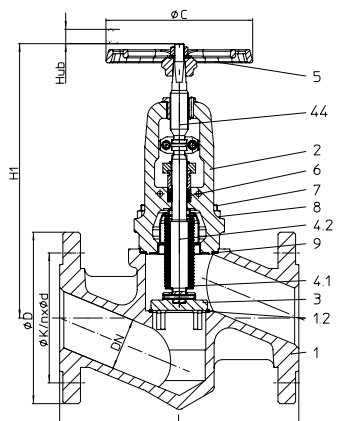
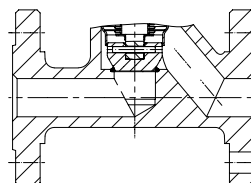
Parts				
Pos.	Sp.p.	Description	Fig. 45.146....153 One-piece stem	Fig. 45.146....154 Two-piece stem
1		Body	P250 GH, 1.0460	
1.2		Seat	G19 9 NbSi, 1.4551	
2	x (Bonnet, opt.)	Bonnet	GP240GH+N, 1.0619+N	
+ 4.1		Bellows seal	X6CrNiMoTi17 12 2, 1.4571	
+ 4.2		Stem	X6CrNiMoTi17 12 2, 1.4571	
+ 6		Packing ring	Pure graphite	
+ 44		Stem, top	--	X39CrMo17-1+QT, 1.4122+QT
3	x	Plug	X20Cr13+QT, 1.4021+QT (hardened)	
5	x	Handwheel	St (cataphoretic coating)	EN-GJS-400-15, EN-JS1030 (epoxy-coating)
7		Stud	25CrMo4, 1.7218	
8		Hexagon nut	C35E, 1.1181	
9	x	Gasket	Pure graphite (with CrNi-grooved)	
L Spare parts				

DN	15	20	25	32	40	50
----	----	----	----	----	----	----

Face-to-face dimension FTF series 1 acc. to DIN EN 558		Standard-flange dimensions refer to page 25					
L	(mm)	130	150	160	180	200	230

Dimensions							
H1 (One-piece stem)	(mm)	235	235	245	250	275	275
H1 (Two-piece stem)	(mm)	250	250	255	260	295	295
ØC (One-piece stem)	(mm)	125	125	125	125	150	150
ØC (Two-piece stem)	(mm)	140	140	140	140	160	160
Travel	(mm)	6	6	8	8	13	13
Kvs-value	(m³/h)	3,3	5,8	9,2	11,5	21,5	32
Zeta-value	--	7,4	7,6	7,4	12,7	8,8	9,7

Zeta-value ... range of tolerance for Kvs-values acc. to VDI/VDE 2173

Weights							
45.146	(kg)	4,4	5,4	6,3	7,8	11	13,5

Information / restriction of technical rules need to be observed!

 Operating and installation instructions can be downloaded at www.ari-armaturen.com.

A production allowance acc. to TRB 801 No. 45 exists

The engineer, designing a system or a plant, is responsible for the selection of the correct valve.

Resistance and fitness must be verified (contact manufacturer for information, refer to Product overview and Resistance list).

Stop valve - straight through with flanges and bellows seal - Industrial version (Stainless steel)

Fig. 146....111 DN15-150
One-piece stem

Fig. 146....112 DN15-150
Two-piece stem

Figure-No.	Nominal pressure	Material	Nominal diameter
54.146....111	PN25	1.4408	DN200-250
55.146....111	PN40	1.4408	DN15-250
54.146....112	PN25	1.4408	DN200-250
55.146....112	PN40	1.4408	DN15-250

Test: • EN ISO 15848-1 / TA - Luft TÜV-Test-No. TA 07 2016 C04

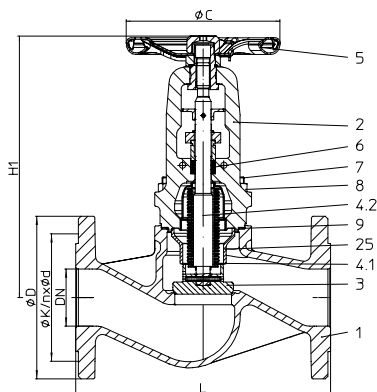
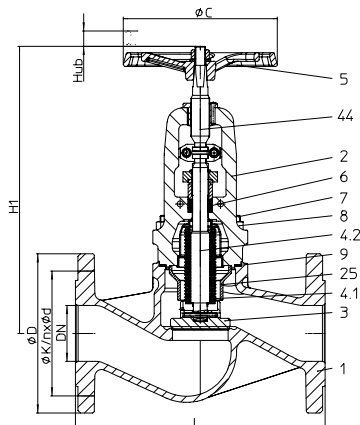
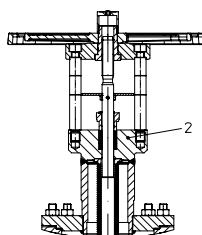
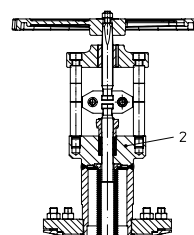
Considered standards: • EN 13709 (1.4408)

Plug design: • Plug with marginal seat standard

At high differential pressures a balancing plug is necessary! (refer to page 21)

Bonnet DN200-250
One-piece stem

Bonnet DN200-250
Two-piece stem

Parts				Fig. 54. / 55. 146....111 One-piece stem	Fig. 54. / 55. 146....112 Two-piece stem
Pos.	Sp.p.	Description			
1		Body	GX5CrNiMo19-11-2, 1.4408		
2	x (Bonnet, opt.)	Bonnet	≤DN150: GX5CrNiMo19-11-2, 1.4408 / ≥DN200: X6CrNiMoTi17-12-2, 1.4571		
+ 4.1		Bellows seal	X6CrNiMoTi17 12 2, 1.4571		
+ 4.2		Stem	X6CrNiMoTi17 12 2, 1.4571		
+ 6		Packing ring	Pure graphite		
+ 44		Stem, top	--	X39CrMo17-1+QT, 1.4122+QT	
3	x	Plug	X6CrNiMoTi17 12 2, 1.4571 / Stellite 6		
5	x	Handwheel	≤DN125: St (cataphoretic coating) / ≥DN150: EN-GJS-400-15, EN-JS1030 (epoxy-coating)		EN-GJS-400-15, EN-JS1030 (epoxy-coating)
7		Stud	A4-70		
8		Hexagon nut	A4		
9	x	Gasket	Pure graphite (with CrNi-grooved)		
25		Guide bush	≤DN32: X6CrNiMoTi17 12 2, 1.4571 / ≥DN40: GX5CrNiMo19-11-2, 1.4408		
L Spare parts					

DN	15	20	25	32	40	50	65	80	100	125	150	200	250
----	----	----	----	----	----	----	----	----	-----	-----	-----	-----	-----

Face-to-face dimension FTF series 1 acc. to DIN EN 558													Standard-flange dimensions refer to page 25	
L	(mm)	130	150	160	180	200	230	290	310	350	400	480	600	730

Dimensions														
H1 (One-piece stem)	(mm)	225	225	230	230	270	275	300	380	460	500	570	780	935
H1 (Two-piece stem)	(mm)	240	240	240	240	290	295	335	395	505	550	605	805	935
øC (One-piece stem)	(mm)	125	125	125	125	150	150	175	225	300	300	400	520	520
øC (Two-piece stem)	(mm)	140	140	140	140	160	160	180	225	300	300	400	520	520
Travel	(mm)	6	6	8	8	13	13	16	20	25	32	40	50	70
Kvs-value	(m³/h)	4,7	6,4	11	15,5	28	42,5	75	105	170	270	405	675	1090
Zeta-value	--	3,7	6,2	5,2	7	5,2	5,5	5,1	5,9	5,5	5,3	4,9	5,6	5,2
Zeta-value ... range of tolerance for Kvs-values acc. to VDI/VDE 2173														

Weights														
54.146	(kg)	--	--	--	--	--	--	--	--	--	--	--	213	300
55.146	(kg)	4,9	5,4	7,1	8,1	11,3	14,1	21,8	30	45,5	63,5	78	245	347

Information / restriction of technical rules need to be observed!
 Operating and installation instructions can be downloaded at www.ari-armaturen.com.
 A production allowance acc. to TRB 801 No. 45 exists
 The engineer, designing a system or a plant, is responsible for the selection of the correct valve.
 Resistance and fitness must be verified (contact manufacturer for information, refer to Product overview and Resistance list).

Stop valve - straight through with flanges and bellows seal - Chemical version (Stainless steel)

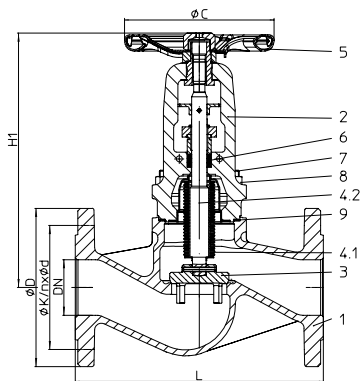
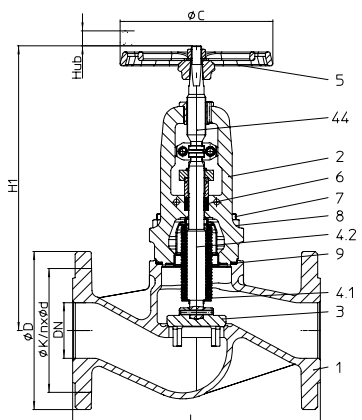
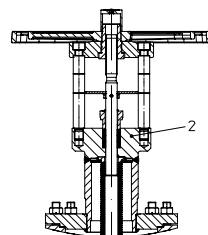
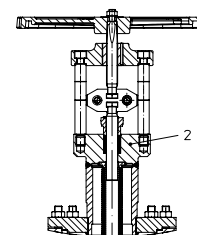

 Fig. 146....153 DN15-150
 One-piece stem

 Fig. 146....154 DN15-150
 Two-piece stem

Figure-No.	Nominal pressure	Material	Nominal diameter
54.146....153	PN25	1.4408	DN200-250
55.146....153	PN40	1.4408	DN15-250
54.146....154	PN25	1.4408	DN200-250
55.146....154	PN40	1.4408	DN15-250

Test: • EN ISO 15848-1 / TA - Luft TÜV-Test-No. TA 07 2016 C04

Considered standards: • EN 13709 (1.4408)

Plug design: V-port plug with marginal seat standard

At high differential pressures a balancing plug is necessary! (refer to page 21)

 Bonnet DN200-250
 One-piece stem

 Bonnet DN200-250
 Two-piece stem

Parts				
Pos.	Sp.p.	Description	Fig. 54. / 55. 146....153 One-piece stem	Fig. 54. / 55. 146....154 Two-piece stem
1		Body	GX5CrNiMo19-11-2, 1.4408	
2	x (Bonnet, cpl.)	Bonnet	≤DN150: GX5CrNiMo19-11-2, 1.4408 / ≥DN200: X6CrNiMoTi17-12-2, 1.4571	
+ 4.1		Bellows seal	X6CrNiMoTi17 12 2, 1.4571	
+ 4.2		Stem	X6CrNiMoTi17 12 2, 1.4571	
+ 6		Packing ring	Pure graphite	
+ 44		Stem, top	--	X39CrMo17-1+QT, 1.4122+QT
3	x	Plug	X6CrNiMoTi17 12 2, 1.4571 / Stellite 6	
5	x	Handwheel	≤DN125: St (cathaphoretic coating) / ≥DN150: EN-GJS-400-15, EN-JS1030 (epoxy-coating)	EN-GJS-400-15, EN-JS1030 (epoxy-coating)
7		Stud	A4-70	
8		Hexagon nut	A4	
9	x	Gasket	Pure graphite (with CrNi-grooved)	
		L Spare parts		

DN	15	20	25	32	40	50	65	80	100	125	150	200	250
----	----	----	----	----	----	----	----	----	-----	-----	-----	-----	-----

Face-to-face dimension FTF series 1 acc. to DIN EN 558													Standard-flange dimensions refer to page 25	
L	(mm)	130	150	160	180	200	230	290	310	350	400	480	600	730

Dimensions														
H1 (One-piece stem)	(mm)	225	225	230	230	270	275	300	380	460	500	570	780	935
H1 (Two-piece stem)	(mm)	240	240	240	240	290	295	335	395	505	550	605	805	935
ØC (One-piece stem)	(mm)	125	125	125	125	150	150	175	225	300	300	400	520	520
ØC (Two-piece stem)	(mm)	140	140	140	140	160	160	180	225	300	300	400	520	520
Travel	(mm)	6	6	8	8	13	13	16	20	25	32	40	50	70
Kvs-value	(m³/h)	4,4	6	10	13,3	25,5	38,5	64	90	135	215	325	580	885
Zeta-value	--	4,2	7,1	6,2	9,5	6,3	6,7	7	8,1	8,8	8,4	7,7	7,6	8

Zeta-value ... range of tolerance for Kvs-values acc. to VDI/VDE 2173

Weights														
54.146	(kg)	--	--	--	--	--	--	--	--	--	--	--	213	300
55.146	(kg)	4,9	5,4	7,1	8,1	11,3	14,1	21,8	30	45,5	63,5	78	245	347

Information / restriction of technical rules need to be observed!
 Operating and installation instructions can be downloaded at www.ari-armaturen.com.
 A production allowance acc. to TRB 801 No. 45 exists
 The engineer, designing a system or a plant, is responsible for the selection of the correct valve.
 Resistance and fitness must be verified (contact manufacturer for information, refer to Product overview and Resistance list).

Stop valve - straight through with butt weld ends and bellows seal - Industrial version (Forged steel)

Fig. 140....111
One-piece stem

Fig. 140....112
Two-piece stem

Figure-No.	Nominal pressure	Material	Nominal diameter
45.140....111	PN40	1.0460	DN15-50
45.140....112	PN40	1.0460	DN15-50
DN >50 refer to Fig. 35.140 (1.0619+N)			

Butt weld ends according to DIN EN 12627 - 4 (refer to page 26)

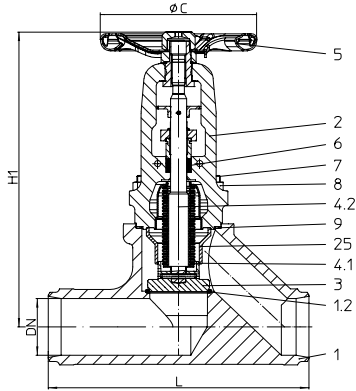
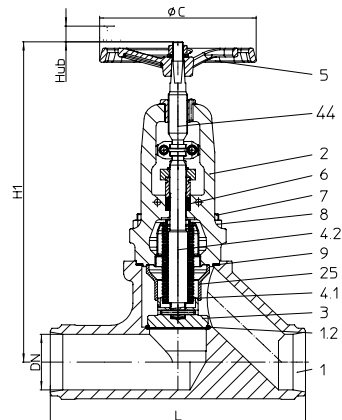
Test: • EN ISO 15848-1 / TA - Luft TÜV-Test-No. TA 07 2016 C04

Considered standards: • EN 13709 (1.0460)

Plug design: • Plug with marginal seat standard

Parts				
Pos.	Sp.p.	Description	Fig. 45. 140....111 One-piece stem	Fig. 45. 140....112 Two-piece stem
1		Body	P250 GH, 1.0460	
1.2		Seat	G19 9 NbSi, 1.4551	
2	x (Bonnet, opt.)	Bonnet	GP240GH+N, 1.0619+N	
+ 4.1		Bellows seal	X6CrNiMoTi17 12 2, 1.4571	
+ 4.2		Stem	X6CrNiMoTi17 12 2, 1.4571	
+ 6		Packing ring	Pure graphite	
+ 44		Stem, top	--	X39CrMo17-1+QT, 1.4122+QT
3	x	Plug	X20Cr13+QT, 1.4021+QT (hardened)	
5	x	Handwheel	St (cataphoretic coating)	EN-GJS-400-15, EN-JS1030 (epoxy-coating)
7		Stud	25CrMo4, 1.7218	
8		Hexagon nut	C35E, 1.1181	
9	x	Gasket	Pure graphite (with CrNi-grooved)	
25		Guide bush	≤DN32: X6CrNiMoTi17 12 2, 1.4571 / ≥DN40: GX5CrNiMo19-11-2, 1.4408	
L Spare parts				

DN	15	20	25	32	40	50
----	----	----	----	----	----	----

Face-to-face dimension ETE series 1 according to DIN EN 12982							
L	(mm)	130	150	160	180	200	230

Dimensions							
H1 (One-piece stem)	(mm)	235	235	245	250	295	300
H1 (Two-piece stem)	(mm)	250	250	255	260	315	320
ØC (One-piece stem)	(mm)	125	125	125	125	150	150
ØC (Two-piece stem)	(mm)	140	140	140	140	160	160
Travel	(mm)	6	6	8	8	13	13
Kvs-value	(m³/h)	3,4	6	9,5	12,5	18,5	28
Zeta-value	--	7	7,1	6,9	10,7	11,9	12,7
Zeta-value ... range of tolerance for Kvs-values acc. to VDI/VDE 2173							

Weights							
45.140	(kg)	3,2	3,4	4,6	5	6,8	9,7

Information / restriction of technical rules need to be observed!

 Operating and installation instructions can be downloaded at www.ari-armaturen.com.

A production allowance acc. to TRB 801 No. 45 exists

The engineer, designing a system or a plant, is responsible for the selection of the correct valve.

Resistance and fitness must be verified (contact manufacturer for information, refer to Product overview and Resistance list).

Stop valve - straight through with butt weld ends and bellows seal - Chemical version (Forged steel)

Fig. 140....153
One-piece stem

Fig. 140....154
Two-piece stem

Figure-No.	Nominal pressure	Material	Nominal diameter
45.140....153	PN40	1.0460	DN15-50
45.140....154	PN40	1.0460	DN15-50

DN >50 refer to Fig. 35.140 (1.0619+N)

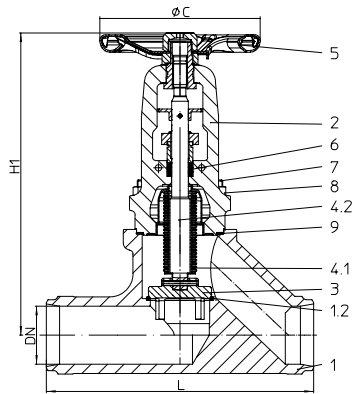
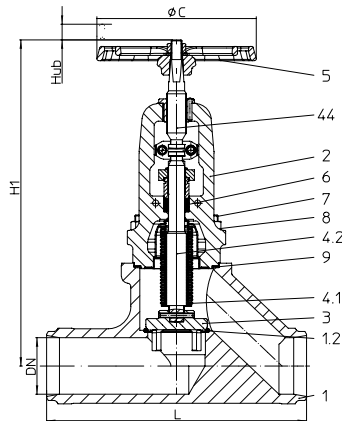
Butt weld ends according to DIN EN 12627 - 4 (refer to page 26)

Test: • EN ISO 15848-1 / TA - Luft TÜV-Test-No. TA 07 2016 C04

Considered standards: • EN 13709 (1.0460)

Plug design: V-port plug with marginal seat standard

Parts				
Pos.	Sp.p.	Description	Fig. 45. 140....153 One-piece stem	Fig. 45. 140....154 Two-piece stem
1		Body	P250 GH, 1.0460	
1.2		Seat	G19 9 NbSi, 1.4551	
2	x (Bonnet, opt.)	Bonnet	GP240GH+N, 1.0619+N	
+ 4.1		Bellows seal	X6CrNiMoTi17 12 2, 1.4571	
+ 4.2		Stem	X6CrNiMoTi17 12 2, 1.4571	
+ 6		Packing ring	Pure graphite	
+ 44		Stem, top	--	X39CrMo17-1+QT, 1.4122+QT
3	x	Plug	X20Cr13+QT, 1.4021+QT (hardened)	
5	x	Handwheel	St (cataphoretic coating)	EN-GJS-400-15, EN-JS1030 (epoxy-coating)
7		Stud	25CrMo4, 1.7218	
8		Hexagon nut	C35E, 1.1181	
9	x	Gasket	Pure graphite (with CrNi-grooved)	
L Spare parts				

DN	15	20	25	32	40	50
----	----	----	----	----	----	----

Face-to-face dimension ETE series 1 according to DIN EN 12982							
L	(mm)	130	150	160	180	200	230

Dimensions							
H1 (One-piece stem)	(mm)	235	235	245	250	295	300
H1 (Two-piece stem)	(mm)	250	250	255	260	315	320
ØC (One-piece stem)	(mm)	125	125	125	125	150	150
ØC (Two-piece stem)	(mm)	140	140	140	140	160	160
Travel	(mm)	6	6	8	8	13	13
Kvs-value	(m³/h)	3,3	5,8	9,2	11,5	19	29
Zeta-value	--	7,4	7,6	7,4	12,7	11,3	11,9

Zeta-value ... range of tolerance for Kvs-values acc. to VDI/VDE 2173

Weights							
45.140	(kg)	3,2	3,4	4,6	5	6,8	9,7

Information / restriction of technical rules need to be observed!

 Operating and installation instructions can be downloaded at www.ari-armaturen.com.

A production allowance acc. to TRB 801 No. 45 exists

The engineer, designing a system or a plant, is responsible for the selection of the correct valve.

Resistance and fitness must be verified (contact manufacturer for information, refer to Product overview and Resistance list).

Stop valve - straight through with butt weld ends and bellows seal - Industrial version (Cast steel)

**Fig. 140....111 DN65-150
One-piece stem**

**Fig. 140....112 DN65-150
Two-piece stem**

Figure-No.	Nominal pressure	Material	Nominal diameter
35.140....111	PN40	1.0619+N	DN65-300
35.140....112	PN40	1.0619+N	DN65-300

DN <65 refer to Fig. 45.140 (1.0460)

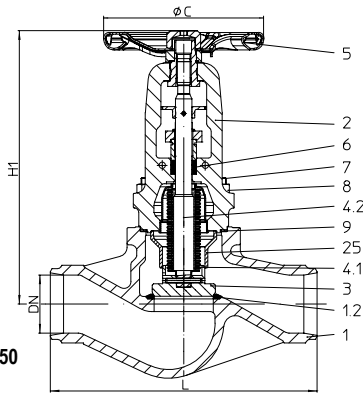
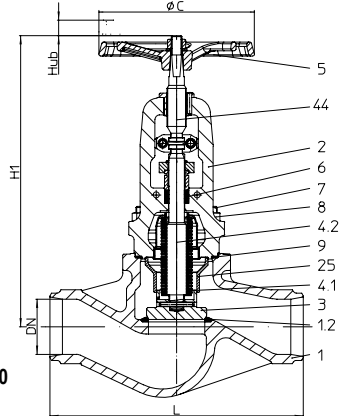
 Butt weld ends according to DIN EN 12627 - 4 (refer to page 26)
 alternative: DN 65-200 with shoed ends of P235GH

Test: • EN ISO 15848-1 / TA - Luft TÜV-Test-No. TA 07 2016 C04

Considered standards: • EN 13709 (1.0619+N)

Plug design: • Plug with marginal seat standard

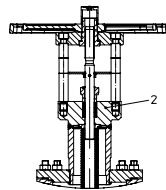
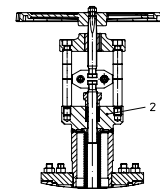
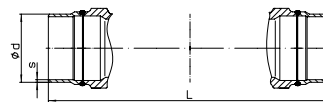
At high differential pressures a balancing plug is necessary! (refer to page 21)

**Bonnet DN200-300
One-piece stem**

**Bonnet DN200-300
Two-piece stem**

alternative

Parts				Fig. 35.140....111 One-piece stem	Fig. 35.140....112 Two-piece stem
Pos.	Sp.p.	Description			
1		Body	GP240GH+N, 1.0619+N		
1.2		Seat	G19 9 NbSi, 1.4551		
2	x (Bonnet, cp.)	Bonnet	≤DN150: GP240GH+N, 1.0619+N / ≥DN200: P250 GH, 1.0460; P235GH-TC1, 1.0345; P265 GH, 1.0425		
+ 4.1		Bellows seal	X6CrNiMoTi17 12 2, 1.4571		
+ 4.2		Stem	X6CrNiMoTi17 12 2, 1.4571		
+ 6		Packing ring	Pure graphite		
+ 44		Stem, top	--	X39CrMo17-1+QT, 1.4122+QT	
3	x	Plug	≤DN150: X20Cr13+QT, 1.4021+QT (hardened) ≥DN200: P265GH, 1.0425 / Stellite 21		
5	x	Handwheel	≤DN125: St (cataphoretic coating) / ≥DN150: EN-GJS-400-15, EN-JS1030 (epoxy-coating)		
7		Stud	25CrMo4, 1.7218		
8		Hexagon nut	C35E, 1.1181		
9	x	Gasket	Pure graphite (with CrNi-grooved)		
25		Guide bush	≤DN32: X6CrNiMoTi17 12 2, 1.4571 / ≥DN40: GX5CrNiMo19-11-2, 1.4408		
L Spare parts					

DN	65	80	100	125	150	200	250	300
----	----	----	-----	-----	-----	-----	-----	-----

Face-to-face dimension ETE series 1 according to DIN EN 12982									
L	(mm)	290	310	350	400	480	600	730	850

Dimensions									
H1 (One-piece stem)	(mm)	300	380	460	500	570	785	940	1025
H1 (Two-piece stem)	(mm)	335	390	505	550	605	810	940	1025
ØC (One-piece stem)	(mm)	175	225	300	300	400	520	520	520
ØC (Two-piece stem)	(mm)	180	225	300	300	400	520	520	520
Travel	(mm)	16	20	25	32	40	50	70	80
Kvs-value	(m³/h)	75	105	170	270	405	675	1090	1460
Zeta-value	--	5,1	5,9	5,5	5,3	4,9	5,6	5,2	6,1
Zeta-value ... range of tolerance for Kvs-values acc. to VDI/VDE 2173									

Weights									
35.140	(kg)	14,8	22	36,2	50	63	186	270	409

Information / restriction of technical rules need to be observed!

 Operating and installation instructions can be downloaded at www.ari-armaturen.com. / A production allowance acc. to TRB 801 No. 45 exists

The engineer, designing a system or a plant, is responsible for the selection of the correct valve.

Resistance and fitness must be verified (contact manufacturer for information, refer to Product overview and Resistance list).

Stop valve - straight through with butt weld ends and bellows seal - Chemical version (Cast steel)

Fig. 140....153 DN65-150
One-piece stem

Fig. 140....154 DN65-150
Two-piece stem

Figure-No.	Nominal pressure	Material	Nominal diameter
35.140....153	PN40	1.0619+N	DN65-300
35.140....154	PN40	1.0619+N	DN65-300
DN <65 refer to Fig. 45.140 (1.0460)			

 Butt weld ends according to DIN EN 12627 - 4 (refer to page 26)
 alternative: DN 65-200 with shoed ends of P235GH

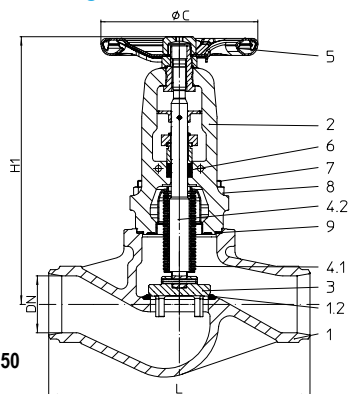
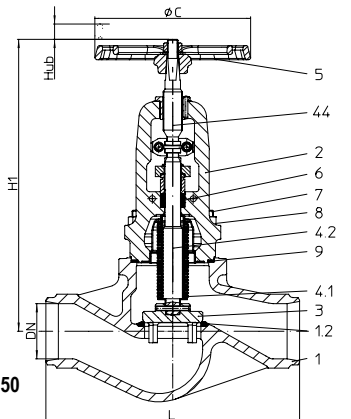
Test: • EN ISO 15848-1 / TA - Luft TÜV-Test-No. TA 07 2016 C04

Considered standards: • EN 13709 (1.0619+N)

Plug design: V-port plug with marginal seat standard

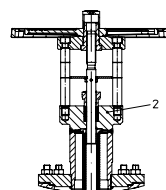
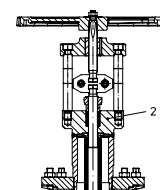
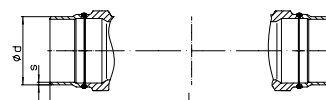
At high differential pressures a balancing plug is necessary! (refer to page 21)

Bonnet DN200-300
One-piece stem

Bonnet DN200-300
Two-piece stem

alternative

Parts				
Pos.	Sp.p.	Description	Fig. 35.140....153 One-piece stem	Fig. 35.140....154 Two-piece stem
1		Body	GP240GH+N, 1.0619+N	
1.2		Seat	G19 9 NbSi, 1.4551	
2	x (Bonnet, cpl.)	Bonnet	≤DN150: GP240GH+N, 1.0619+N / ≥DN200: P250 GH, 1.0460; P235GH-TC1, 1.0345; P265 GH, 1.0425	
+ 4.1		Bellows seal	X6CrNiMoTi17 12 2, 1.4571	
+ 4.2		Stem	X6CrNiMoTi17 12 2, 1.4571	
+ 6		Packing ring	Pure graphite	
+ 44		Stem, top	--	X39CrMo17-1+QT, 1.4122+QT
3	x	Plug	≤DN150: X20Cr13+QT, 1.4021+QT (hardened) ≥DN200: P265GH, 1.0425 / Stellite 21	
5	x	Handwheel	≤DN125: St (cataphoretic coating) / ≥DN150: EN-GJS-400-15, EN-JS1030 (epoxy-coating)	EN-GJS-400-15, EN-JS1030 (epoxy-coating)
7		Stud	25CrMo4, 1.7218	
8		Hexagon nut	C35E, 1.1181	
9	x	Gasket	Pure graphite (with CrNi-grooved)	
L Spare parts				

DN	65	80	100	125	150	200	250	300
----	----	----	-----	-----	-----	-----	-----	-----

Face-to-face dimension ETE series 1 according to DIN EN 12982									
L	(mm)	290	310	350	400	480	600	730	850

Dimensions									
H1 (One-piece stem)	(mm)	300	380	460	500	570	785	940	1025
H1 (Two-piece stem)	(mm)	335	390	505	550	605	810	940	1025
ØC (One-piece stem)	(mm)	175	225	300	300	400	520	520	520
ØC (Two-piece stem)	(mm)	180	225	300	300	400	520	520	520
Travel	(mm)	16	20	25	32	40	50	70	80
Kvs-value	(m³/h)	64	90	135	215	325	580	885	1290
Zeta-value	--	7	8,1	8,8	8,4	7,7	7,6	8	7,8

Zeta-value ... range of tolerance for Kvs-values acc. to VDI/VDE 2173

Weights									
35.140	(kg)	14,8	22	36,2	50	63	186	270	409

Information / restriction of technical rules need to be observed!

 Operating and installation instructions can be downloaded at www.ari-armaturen.com.

A production allowance acc. to TRB 801 No. 45 exists / The engineer, designing a system or a plant, is responsible for the selection of the correct valve.

Resistance and fitness must be verified (contact manufacturer for information, refer to Product overview and Resistance list).

Stop valve - Y-pattern with flanges and bellows seal - Industrial version (Stainless steel)

Fig. 169....111 DN15-150
 One-piece stem

Fig. 169....112 DN15-150
 Two-piece stem

Figure-No.	Nominal pressure	Material	Nominal diameter
54.169....111	PN25	1.4408	DN15-200
55.169....111	PN40	1.4408	DN15-150
54.169....112	PN25	1.4408	DN15-200
55.169....112	PN40	1.4408	DN15-150

Test: • EN ISO 15848-1 / TA - Luft TÜV-Test-No. TA 07 2016 C04

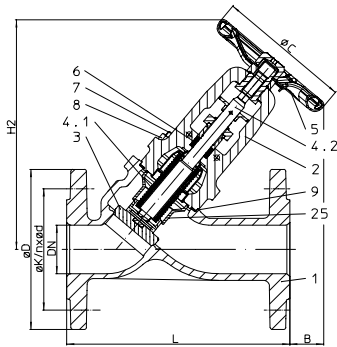
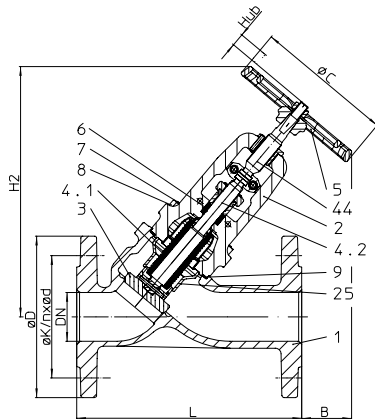
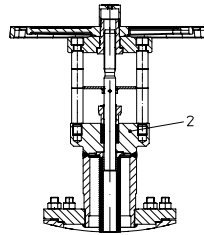
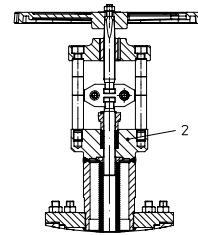
Considered standards: • EN 13709 (1.4408)

Plug design: • Plug with marginal seat standard

At high differential pressures a balancing plug is necessary! (refer to page 21)

Bonnet DN200
 One-piece stem

Bonnet DN200
 Two-piece stem

Parts					
Pos.	Sp.p.	Description	Fig. 54. / 55.169....111 One-piece stem	Fig. 54. / 55.169....112 Two-piece stem	
1		Body	GX5CrNiMo19-11-2, 1.4408		
2		Bonnet	≤DN150: GX5CrNiMo19-11-2, 1.4408 / ≥DN200: X6CrNiMoTi17-12-2, 1.4571		
+ 4.1	x (Bonnet, opt.)	Bellows seal	X6CrNiMoTi17 12 2, 1.4571		
+ 4.2		Stem	X6CrNiMoTi17 12 2, 1.4571		
+ 6		Packing ring	Pure graphite		
+ 44		Stem, top	--	X39CrMo17-1+QT, 1.4122+QT	
3	x	Plug	X6CrNiMoTi17 12 2, 1.4571 / Stellite 6		
5	x	Handwheel	≤DN125: St (cataphoretic coating) / ≥DN150: EN-GJS-400-15, EN-JS1030 (epoxy-coating)	EN-GJS-400-15, EN-JS1030 (epoxy-coating)	
7		Stud	A4-70		
8		Hexagon nut	A4		
9	x	Gasket	Pure graphite (with CrNi-grooved)		
25		Guide bush	≤DN32: X6CrNiMoTi17 12 2, 1.4571 / ≥DN40: GX5CrNiMo19-11-2, 1.4408		
L Spare parts					

DN	15	20	25	32	40	50	65	80	100	125	150	200
----	----	----	----	----	----	----	----	----	-----	-----	-----	-----

Face-to-face dimension FTF series 1 acc. to DIN EN 558												Standard-flange dimensions refer to page 25	
L	(mm)	130	150	160	180	200	230	290	310	350	400	480	600

Dimensions													
H2 (One-piece stem)	(mm)	210	210	220	220	270	270	310	385	455	500	590	828
H2 (Two-piece stem)	(mm)	225	225	230	230	285	285	365	400	490	535	615	875
ØC (One-piece stem)	(mm)	125	125	125	125	150	150	175	225	300	300	400	520
ØC (Two-piece stem)	(mm)	140	140	140	140	160	160	180	225	300	300	400	520
B (One-piece stem)	(mm)	110	85	85	70	95	65	50	125	185	170	180	255
B (Two-piece stem)	(mm)	120	95	90	75	110	80	75	135	210	200	205	590
Travel	(mm)	6	6	8	8	13	13	16	20	25	32	40	50
Kvs-value	(m³/h)	6	9	14	19	32,5	48	83	119	190	300	450	745
Zeta-value	--	2,2	3,2	3,2	4,6	3,9	4,3	4,1	4,6	4,4	4,3	4	4,6

Zeta-value ... range of tolerance for Kvs-values acc. to VDI/VDE 2173

Weights													
54. / 55.169	(kg)	4,6	5,1	6,2	7,3	9,5	13,2	18,8	26,8	43,7	53,8	69	206

Information / restriction of technical rules need to be observed!

 Operating and installation instructions can be downloaded at www.ari-armaturen.com. / A production allowance acc. to TRB 801 No. 45 exists

The engineer, designing a system or a plant, is responsible for the selection of the correct valve.

Resistance and fitness must be verified (contact manufacturer for information, refer to Product overview and Resistance list).

Stop valve - Y-pattern with flanges and bellows seal - Chemical version (Stainless steel)

Fig. 169....153 DN15-150
One-piece stem

Fig. 169....154 DN15-150
Two-piece stem

Figure-No.	Nominal pressure	Material	Nominal diameter
54.169....153	PN25	1.4408	DN15-200
55.169....153	PN40	1.4408	DN15-150
54.169....154	PN25	1.4408	DN15-200
55.169....154	PN40	1.4408	DN15-150

Test:	• EN ISO 15848-1 / TA - Luft TÜV-Test-No. TA 07 2016 C04
-------	--

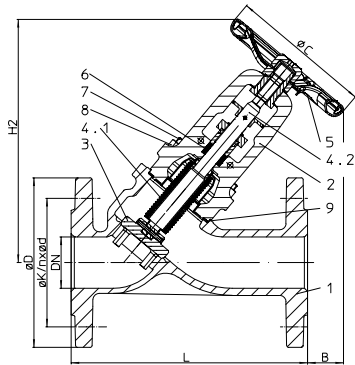
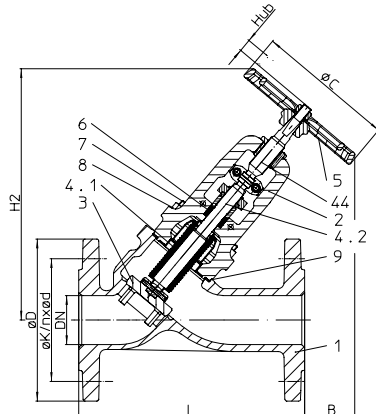
Considered standards:	• EN 13709 (1.4408)
-----------------------	---------------------

Plug design:	V-port plug with marginal seat standard
--------------	---

At high differential pressures a balancing plug is necessary! (refer to page 21)

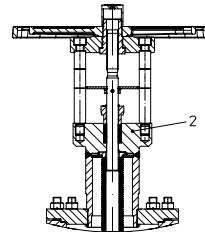
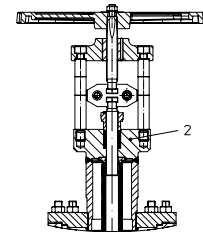
Bonnet DN200
One-piece stem

Bonnet DN200
Two-piece stem

Parts				
Pos.	Sp.p.	Description	Fig. 54. / 55.169....153 One-piece stem	Fig. 54. / 55.169....154 Two-piece stem
1		Body	GX5CrNiMo19-11-2, 1.4408	
2		Bonnet	≤DN150: GX5CrNiMo19-11-2, 1.4408 / ≥DN200: X6CrNiMoTi17-12-2, 1.4571	
+ 4.1	x (Bonnet, cpl.)	Bellows seal	X6CrNiMoTi17 12 2, 1.4571	
+ 4.2		Stem	X6CrNiMoTi17 12 2, 1.4571	
+ 6		Packing ring	Pure graphite	
+ 44		Stem, top	--	X39CrMo17-1+QT, 1.4122+QT
3	x	Plug	X6CrNiMoTi17 12 2, 1.4571 / Stellite 6	
5	x	Handwheel	≤DN125: St (cataphoretic coating) / ≥DN150: EN-GJS-400-15, EN-JS1030 (epoxy-coating)	EN-GJS-400-15, EN-JS1030 (epoxy-coating)
7		Stud	A4-70	
8		Hexagon nut	A4	
9	x	Gasket	Pure graphite (with CrNi-grooved)	
	L	Spare parts		

DN	15	20	25	32	40	50	65	80	100	125	150	200
----	----	----	----	----	----	----	----	----	-----	-----	-----	-----

Face-to-face dimension FTF series 1 acc. to DIN EN 558											Standard-flange dimensions refer to page 25		
L	(mm)	130	150	160	180	200	230	290	310	350	400	480	600

Dimensions													
H2 (One-piece stem)	(mm)	210	210	220	220	270	270	310	385	455	500	590	828
H2 (Two-piece stem)	(mm)	225	225	230	230	285	285	365	400	490	535	615	875
ØC (One-piece stem)	(mm)	125	125	125	125	150	150	175	225	300	300	400	520
ØC (Two-piece stem)	(mm)	140	140	140	140	160	160	180	225	300	300	400	520
B (One-piece stem)	(mm)	110	85	85	70	95	65	50	125	185	170	180	255
B (Two-piece stem)	(mm)	120	95	90	75	110	80	75	135	210	200	205	590
Travel	(mm)	6	6	8	8	13	13	16	20	25	32	40	50
Kvs-value	(m³/h)	5,5	8	12,5	17	28	42	72	100	150	239	360	595
Zeta-value	--	2,7	4	4	5,8	5,2	5,7	5,5	6,5	7,1	6,8	6,2	7,2

Zeta-value ... range of tolerance for Kvs-values acc. to VDI/VDE 2173

Weights													
54. / 55.169	(kg)	4,6	5,1	6,2	7,3	9,5	13,2	18,8	26,8	43,7	53,8	69	206

Information / restriction of technical rules need to be observed!

Operating and installation instructions can be downloaded at www.ari-armaturen.com.

A production allowance acc. to TRB 801 No. 45 exists / The engineer, designing a system or a plant, is responsible for the selection of the correct valve.

Resistance and fitness must be verified (contact manufacturer for information, refer to Product overview and Resistance list).

Stop valve - Y-pattern with butt weld ends and bellows seal - Industrial version (Cast steel)

Fig. 166....111 DN15-150
 One-piece stem

Fig. 166....112 DN15-150
 Two-piece stem

Figure-No.	Nominal pressure	Material	Nominal diameter
35.166....111	PN40	1.0619+N	DN15-300
35.166....112	PN40	1.0619+N	DN15-300

Butt weld ends according to DIN EN 12627 - 4 (refer to page 26)

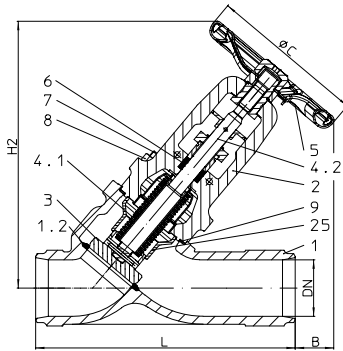
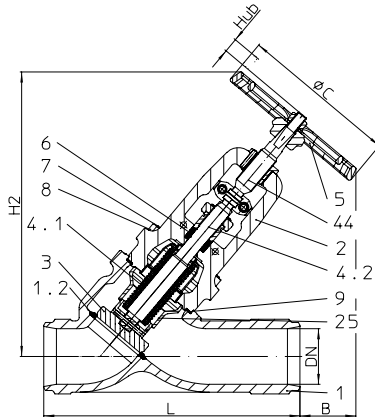
Test: • EN ISO 15848-1 / TA - Luft TÜV-Test-No. TA 07 2016 C04

Considered standards: • EN 13709 (1.0619+N)

Plug design: • Plug with marginal seat standard

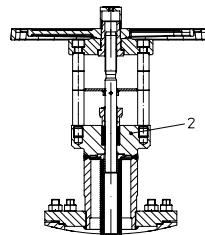
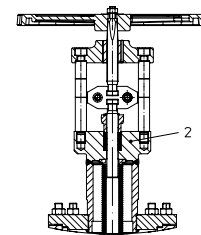
At high differential pressures a balancing plug is necessary! (refer to page 21)

Bonnet DN200-300
 One-piece stem

Bonnet DN200-300
 Two-piece stem

Parts			Fig. 35.166....111 One-piece stem	Fig. 35.166....112 Two-piece stem
1		Body	GP240GH+N, 1.0619+N	
1.2		Seat	G19 9 NbSi, 1.4551	
2	x (Bonnet, opt.)	Bonnet	≤DN150: GP240GH+N, 1.0619+N / ≥DN200: P250 GH, 1.0460; P235GH-TC1, 1.0345; P265 GH, 1.0425	
+ 4.1		Bellows seal	X6CrNiMoTi17 12 2, 1.4571	
+ 4.2		Stem	X6CrNiMoTi17 12 2, 1.4571	
+ 6		Packing ring	Pure graphite	
+ 44		Stem, top	--	X39CrMo17-1+QT, 1.4122+QT
3	x	Plug	≤DN150: X20Cr13+QT, 1.4021+QT (hardened) / ≥DN200: P265GH, 1.0425 / Stellite 21	
5	x	Handwheel	≤DN125: St (cataphoretic coating) / ≥DN150: EN-GJS-400-15, EN-JS1030 (epoxy-coating)	EN-GJS-400-15, EN-JS1030 (epoxy-coating)
7		Stud	25CrMo4, 1.7218	
8		Hexagon nut	C35E, 1.1181	
9	x	Gasket	Pure graphite (with CrNi-grooved)	
25		Guide bush	≤DN32: X6CrNiMoTi17 12 2, 1.4571 / ≥DN40: GX5CrNiMo19-11-2, 1.4408	
L Spare parts				

DN	15	20	25	32	40	50	65	80	100	125	150	200	250	300
----	----	----	----	----	----	----	----	----	-----	-----	-----	-----	-----	-----

Face-to-face dimension ETE series 1 according to DIN EN 12982															
L	(mm)	130	150	160	180	200	230	290	310	350	400	480	600	730	850

Dimensions															
H2 (One-piece stem)	(mm)	210	210	220	220	270	270	310	385	455	500	590	795	905	990
H2 (Two-piece stem)	(mm)	225	225	230	230	285	285	365	400	490	535	615	840	950	1035
ØC (One-piece stem)	(mm)	125	125	125	125	150	150	175	225	300	300	400	520	520	520
ØC (Two-piece stem)	(mm)	140	140	140	140	160	160	180	225	300	300	400	520	520	520
B (One-piece stem)	(mm)	110	85	85	70	95	65	50	125	185	170	180	255	235	205
B (Two-piece stem)	(mm)	120	95	90	75	110	80	75	135	210	200	205	290	270	240
Travel	(mm)	6	6	8	8	13	13	16	20	25	32	40	50	70	80
Kvs-value	(m³/h)	6	9	14	19	32,5	48	83	119	190	300	450	745	1200	1610
Zeta-value	--	2,2	3,2	3,2	4,6	3,9	4,3	4,1	4,6	4,4	4,3	4	4,6	4,3	5
Zeta-value ... range of tolerance for Kvs-values acc. to VDI/VDE 2173															

Weights															
35.166	(kg)	3,4	3,6	4,2	4,4	5,5	8,8	11,8	16,5	42,5	52,5	69	164	257	349

Information / restriction of technical rules need to be observed!

 Operating and installation instructions can be downloaded at www.ari-armaturen.com. / A production allowance acc. to TRB 801 No. 45 exists

The engineer, designing a system or a plant, is responsible for the selection of the correct valve.

Resistance and fitness must be verified (contact manufacturer for information, refer to Product overview and Resistance list).

Stop valve - Y-pattern with butt weld ends and bellows seal - Chemical version (Cast steel)

Fig. 166....153 DN15-150
One-piece stem

Fig. 166....154 DN15-150
Two-piece stem

Figure-No.	Nominal pressure	Material	Nominal diameter
35.166....153	PN40	1.0619+N	DN15-300
35.166....154	PN40	1.0619+N	DN15-300

Butt weld ends according to DIN EN 12627 - 4 (refer to page 26)

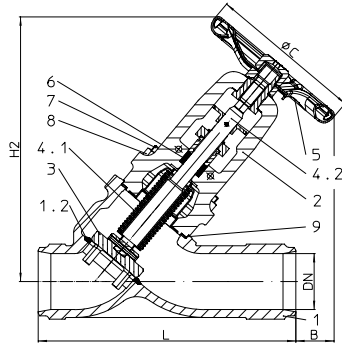
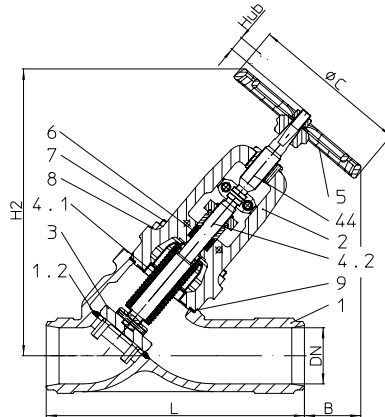
Test: • EN ISO 15848-1 / TA - Luft TÜV-Test-No. TA 07 2016 C04

Considered standards: • EN 13709 (1.0619+N)

Plug design: V-port plug with marginal seat standard

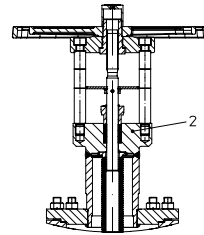
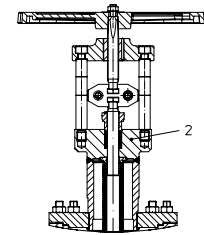
At high differential pressures a balancing plug is necessary! (refer to page 21)

Bonnet DN200-300
One-piece stem

Bonnet DN200-300
Two-piece stem

Parts				Fig. 35.166....153 One-piece stem	Fig. 35.166....154 Two-piece stem
1		Body	GP240GH+N, 1.0619+N		
1.2		Seat	G19 9 NbSi, 1.4551		
2	x (Bonnet, cpl.)	Bonnet	≤DN150: GP240GH+N, 1.0619+N / ≥DN200: P250 GH, 1.0460; P235GH-TC1, 1.0345; P265 GH, 1.0425		
+ 4.1		Bellows seal	X6CrNiMoTi17 12 2, 1.4571		
+ 4.2		Stem	X6CrNiMoTi17 12 2, 1.4571		
+ 6		Packing ring	Pure graphite		
+ 44		Stem, top	--	X39CrMo17-1+QT, 1.4122+QT	
3	x	Plug	≤DN150: X20Cr13+QT, 1.4021+QT (hardened) ≥DN200: P265GH, 1.0425 / Stellite 21		
5	x	Handwheel	≤DN125: St (cataphoretic coating) / ≥DN150: EN-GJS-400-15, EN-JS1030 (epoxy-coating)		
7		Stud	25CrMo4, 1.7218		
8		Hexagon nut	C35E, 1.1181		
9	x	Gasket	Pure graphite (with CrNi-grooved)		
L Spare parts					

DN	15	20	25	32	40	50	65	80	100	125	150	200	250	300
----	----	----	----	----	----	----	----	----	-----	-----	-----	-----	-----	-----

Face-to-face dimension ETE series 1 according to DIN EN 12982															
L	(mm)	130	150	160	180	200	230	290	310	350	400	480	600	730	850

Dimensions															
H2 (One-piece stem)	(mm)	210	210	220	220	270	270	310	385	455	500	590	795	905	990
H2 (Two-piece stem)	(mm)	225	225	230	230	285	285	365	400	490	535	615	840	950	1035
ØC (One-piece stem)	(mm)	125	125	125	125	150	150	175	225	300	300	400	520	520	520
ØC (Two-piece stem)	(mm)	140	140	140	140	160	160	180	225	300	300	400	520	520	520
B (One-piece stem)	(mm)	110	85	85	70	95	65	50	125	185	170	180	255	235	205
B (Two-piece stem)	(mm)	120	95	90	75	110	80	75	135	210	200	205	290	270	240
Travel	(mm)	6	6	8	8	13	13	16	20	25	32	40	50	70	80
Kvs-value	(m³/h)	5,5	8	12,5	17	28	42	72	100	150	239	360	595	960	1280
Zeta-value	--	2,7	4	4	5,8	5,2	5,7	5,5	6,5	7,1	6,8	6,2	7,2	6,8	7,9

Zeta-value ... range of tolerance for Kvs-values acc. to VDI/VDE 2173

Weights															
35.166	(kg)	3,4	3,6	4,2	4,4	5,5	8,8	11,8	16,5	42,5	52,5	69	164	257	349

Information / restriction of technical rules need to be observed!

 Operating and installation instructions can be downloaded at www.ari-armaturen.com.

A production allowance acc. to TRB 801 No. 45 exists / The engineer, designing a system or a plant, is responsible for the selection of the correct valve.

Resistance and fitness must be verified (contact manufacturer for information, refer to Product overview and Resistance list).

Stop valve - Y-pattern with butt weld ends and bellows seal - Industrial version (Stainless steel)

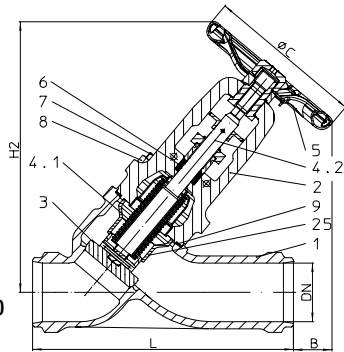
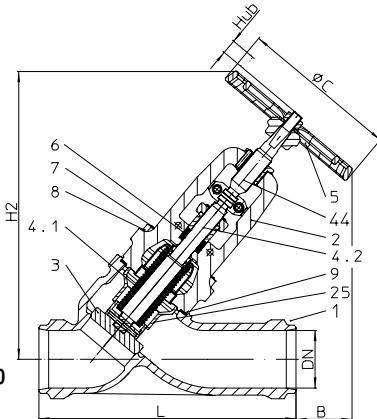

Fig. 166....111 DN15-150
 One-piece stem

Fig. 166....112 DN15-150
 Two-piece stem

Figure-No.	Nominal pressure	Material	Nominal diameter
55.166....111	PN40	1.4581	DN15-200
55.166....112	PN40	1.4581	DN15-200

Butt weld ends according to DIN EN 12627 - 4 (refer to page 26)

Test: • EN ISO 15848-1 / TA - Luft TÜV-Test-No. TA 07 2016 C04

Considered standards: • EN 13709 (1.4581)

Plug design: • Plug with marginal seat standard

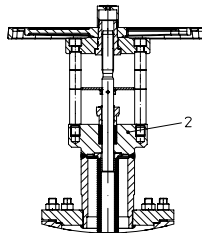
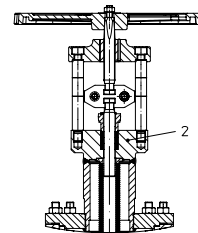
At high differential pressures a balancing plug is necessary! (refer to page 21)

Bonnet DN200
 One-piece stem

Bonnet DN200
 Two-piece stem

Parts				Fig. 55.166....111 One-piece stem	Fig. 55.166....112 Two-piece stem
Pos.	Sp.p.	Description			
1		Body	GX5CrNiMoN19-11-2, 1.4581		
2		Bonnet	≤DN150: GX5CrNiMo19-11-2, 1.4408 / ≥DN200: X6CrNiMoTi17-12-2, 1.4571		
+ 4.1	x (Bonnet, opt.)	Bellows seal	X6CrNiMoTi17 12 2, 1.4571		
+ 4.2		Stem	X6CrNiMoTi17 12 2, 1.4571		
+ 6		Packing ring	Pure graphite		
+ 44		Stem, top	--	X39CrMo17-1+QT, 1.4122+QT	
3	x	Plug	X6CrNiMoTi17 12 2, 1.4571 / Stellite 6		
5	x	Handwheel	≤DN125: St (cataphoretic coating) / ≥DN150: EN-GJS-400-15, EN-JS1030 (epoxy-coating)	EN-GJS-400-15, EN-JS1030 (epoxy-coating)	
7		Stud	A4-70		
8		Hexagon nut	A4		
9	x	Gasket	Pure graphite (with CrNi-grooved)		
25		Guide bush	≤DN32: X6CrNiMoTi17 12 2, 1.4571 / ≥DN40: GX5CrNiMo19-11-2, 1.4408		
L Spare parts					

DN	15	20	25	32	40	50	65	80	100	125	150	200
----	----	----	----	----	----	----	----	----	-----	-----	-----	-----

Face-to-face dimension ETE series 1 according to DIN EN 12982													
L	(mm)	130	150	160	180	200	230	290	310	350	400	480	600

Dimensions													
H2 (One-piece stem)	(mm)	210	210	220	220	270	270	310	385	455	500	590	795
H2 (Two-piece stem)	(mm)	225	225	230	230	285	285	365	400	490	535	615	840
ØC (One-piece stem)	(mm)	125	125	125	125	150	150	175	225	300	300	400	520
ØC (Two-piece stem)	(mm)	140	140	140	140	160	160	180	225	300	300	400	520
B (One-piece stem)	(mm)	110	85	85	70	95	65	50	125	185	170	180	255
B (Two-piece stem)	(mm)	120	95	90	75	110	80	75	135	210	200	205	290
Travel	(mm)	6	6	8	8	13	13	16	20	25	32	40	50
Kvs-value	(m³/h)	6	9	14	19	32,5	48	83	119	190	300	450	745
Zeta-value	--	2,2	3,2	3,2	4,6	3,9	4,3	4,1	4,6	4,4	4,3	4	4,6

Zeta-value ... range of tolerance for Kvs-values acc. to VDI/VDE 2173

Weights													
55.166	(kg)	3,8	4,2	4,8	5,6	7,8	10	12,8	18,9	45	55,3	73	183

Information / restriction of technical rules need to be observed!

 Operating and installation instructions can be downloaded at www.ari-armaturen.com.

A production allowance acc. to TRB 801 No. 45 exists

The engineer, designing a system or a plant, is responsible for the selection of the correct valve.

Resistance and fitness must be verified (contact manufacturer for information, refer to Product overview and Resistance list).

Stop valve - Y-pattern with butt weld ends and bellows seal - Chemical version (Stainless steel)

Fig. 166....153 DN15-150
One-piece stem

Fig. 166....154 DN15-150
Two-piece stem

Figure-No.	Nominal pressure	Material	Nominal diameter
55.166....153	PN40	1.4581	DN15-200
55.166....154	PN40	1.4581	DN15-200

Butt weld ends according to DIN EN 12627 - 4 (refer to page 26)

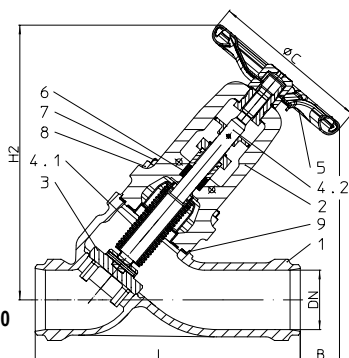
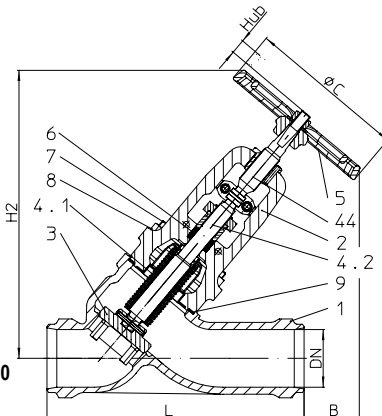
Test: • EN ISO 15848-1 / TA - Luft TÜV-Test-No. TA 07 2016 C04

Considered standards: • EN 13709 (1.4581)

Plug design: V-port plug with marginal seat standard

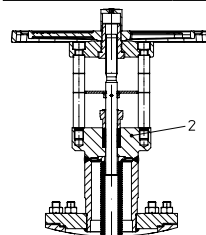
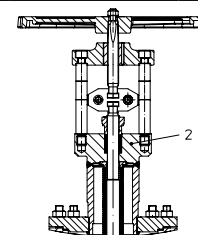
At high differential pressures a balancing plug is necessary! (refer to page 21)

Bonnet DN200
One-piece stem

Bonnet DN200
Two-piece stem

Parts				Fig. 55.166....153 One-piece stem	Fig. 55.166....154 Two-piece stem
1		Body	GX5CrNiMoN19-11-2, 1.4581		
2	x (Bonnet, cpl.)	Bonnet	≤DN150: GX5CrNiMo19-11-2, 1.4408 / ≥DN200: X6CrNiMoTi17-12-2, 1.4571		
+ 4.1		Bellows seal	X6CrNiMoTi17 12 2, 1.4571		
+ 4.2		Stem	X6CrNiMoTi17 12 2, 1.4571		
+ 6		Packing ring	Pure graphite		
+ 44		Stem, top	--	X39CrMo17-1+QT, 1.4122+QT	
3	x	Plug	X6CrNiMoTi17 12 2, 1.4571 / Stellite 6		
5	x	Handwheel	≤DN125: St (cataphoretic coating) / ≥DN150: EN-GJS-400-15, EN-JS1030 (epoxy-coating)		
7		Stud	A4-70		
8		Hexagon nut	A4		
9	x	Gasket	Pure graphite (with CrNi-grooved)		
		L Spare parts			

DN	15	20	25	32	40	50	65	80	100	125	150	200
----	----	----	----	----	----	----	----	----	-----	-----	-----	-----

Face-to-face dimension ETE series 1 according to DIN EN 12982													
L	(mm)	130	150	160	180	200	230	290	310	350	400	480	600

Dimensions													
H2 (One-piece stem)	(mm)	210	210	220	220	270	270	310	385	455	500	590	795
H2 (Two-piece stem)	(mm)	225	225	230	230	285	285	365	400	490	535	615	840
ØC (One-piece stem)	(mm)	125	125	125	125	150	150	175	225	300	300	400	520
ØC (Two-piece stem)	(mm)	140	140	140	140	160	160	180	225	300	300	400	520
B (One-piece stem)	(mm)	110	85	85	70	95	65	50	125	185	170	180	255
B (Two-piece stem)	(mm)	120	95	90	75	110	80	75	135	210	200	205	290
Travel	(mm)	6	6	8	8	13	13	16	20	25	32	40	50
Kvs-value	(m³/h)	5,5	8	12,5	17	28	42	72	100	150	239	360	595
Zeta-value	--	2,7	4	4	5,8	5,2	5,7	5,5	6,5	7,1	6,8	6,2	7,2

Zeta-value ... range of tolerance for Kvs-values acc. to VDI/VDE 2173

Weights													
55.166	(kg)	3,8	4,2	4,8	5,6	7,8	10	12,8	18,9	45	55,3	73	183

Information / restriction of technical rules need to be observed!

 Operating and installation instructions can be downloaded at www.ari-armaturen.com.

A production allowance acc. to TRB 801 No. 45 exists

The engineer, designing a system or a plant, is responsible for the selection of the correct valve.

Resistance and fitness must be verified (contact manufacturer for information, refer to Product overview and Resistance list).

Stop valve - angle pattern with flanges and bellows seal - Industrial version (Cast steel)

Fig. 147....111 DN15-150
One-piece stem

Fig. 147....112 DN15-150
Two-piece stem

Figure-No.	Nominal pressure	Material	Nominal diameter
34.147....111	PN25	1.0619+N	DN200-300
35.147....111	PN40	1.0619+N	DN15-150
34.147....112	PN25	1.0619+N	DN200-300
35.147....112	PN40	1.0619+N	DN15-150

Test: • EN ISO 15848-1 / TA - Luft TÜV-Test-No. TA 07 2016 C04

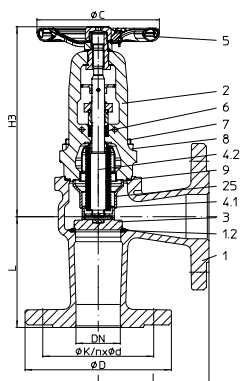
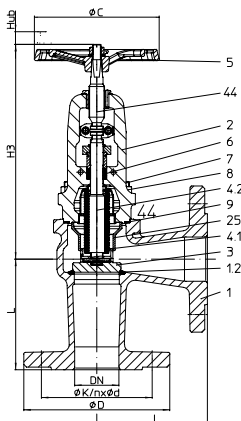
Considered standards: • EN 13709 (1.0619+N)

Plug design: • Plug with marginal seat standard

At high differential pressures a balancing plug is necessary! (refer to page 21)

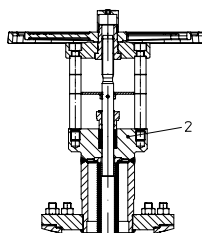
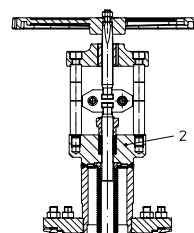
Bonnet DN200
One-piece stem

Bonnet DN200
Two-piece stem

Parts				Fig. 34. / 35.147....111 One-piece stem	Fig. 34. / 35.147....112 Two-piece stem
1		Body	GP240GH+N, 1.0619+N		
1.2		Seat	G19 9 NbSi, 1.4551		
2	x (Bonnet, opt.)	Bonnet	≤DN150: GP240GH+N, 1.0619+N / ≥DN200: P250 GH, 1.0460; P235GH-TC1, 1.0345; P265 GH, 1.0425		
+ 4.1		Bellows seal	X6CrNiMoTi17 12 2, 1.4571		
+ 4.2		Stem	X6CrNiMoTi17 12 2, 1.4571		
+ 6		Packing ring	Pure graphite		
+ 44		Stem, top	--	X39CrMo17-1+QT, 1.4122+QT	
3	x	Plug	≤DN150: X20Cr13+QT, 1.4021+QT (hardened) / ≥DN200: P265GH, 1.0425 / Stellite 21		
5	x	Handwheel	≤DN125: St (cataphoretic coating) / ≥DN150: EN-GJS-400-15, EN-JS1030 (epoxy-coating) / EN-GJS-400-15, EN-JS1030 (epoxy-coating)		
7		Stud	25CrMo4, 1.7218		
8		Hexagon nut	C35E, 1.1181		
9	x	Gasket	Pure graphite (with CrNi-grooved)		
25		Guide bush	≤DN32: X6CrNiMoTi17 12 2, 1.4571 / ≥DN40: GX5CrNiMo19-11-2, 1.4408		
L Spare parts					

DN	15	20	25	32	40	50	65	80	100	125	150	200	250	300
----	----	----	----	----	----	----	----	----	-----	-----	-----	-----	-----	-----

Face-to-face dimension CTF series 8 acc. to DIN EN 558											Standard-flange dimensions refer to page 25				
l	(mm)	90	95	100	105	115	125	145	155	175	200	225	275	325	375

Dimensions															
H3 (One-piece stem)	(mm)	210	210	215	215	255	255	275	350	420	450	510	720	835	915
H3 (Two-piece stem)	(mm)	225	225	225	225	275	275	310	365	465	500	545	745	835	915
ØC (One-piece stem)	(mm)	125	125	125	125	150	150	175	225	300	300	400	520	520	520
ØC (Two-piece stem)	(mm)	140	140	140	140	160	160	180	225	300	300	400	520	520	520
Travel	(mm)	6	6	8	8	13	13	16	20	25	32	40	50	70	80
Kvs-value	(m³/h)	6	9	14	19	33	49	85	129	220	350	530	760	1225	1645
Zeta-value	--	2,2	3,2	3,2	4,6	3,8	4,2	3,9	3,9	3,3	3,2	2,9	4,4	4,2	4,8
Zeta-value ... range of tolerance for Kvs-values acc. to VDI/VDE 2173															

Weights															
34. / 35.147	(kg)	5,2	7	7,5	8,3	11,1	14,2	20,3	27	46,5	59	67	180	270	347

Information / restriction of technical rules need to be observed!

Operating and installation instructions can be downloaded at www.ari-armaturen.com.

A production allowance acc. to TRB 801 No. 45 exists

The engineer, designing a system or a plant, is responsible for the selection of the correct valve.

Resistance and fitness must be verified (contact manufacturer for information, refer to Product overview and Resistance list).

Stop valve - angle pattern with flanges and bellows seal - Chemical version (Cast steel)

Fig. 147....153 DN15-150
One-piece stem

Fig. 147....154 DN15-150
Two-piece stem

Figure-No.	Nominal pressure	Material	Nominal diameter
34.147....153	PN25	1.0619+N	DN200-300
35.147....153	PN40	1.0619+N	DN15-150
34.147....154	PN25	1.0619+N	DN200-300
35.147....154	PN40	1.0619+N	DN15-150

Test: • EN ISO 15848-1 / TA - Luft TÜV-Test-No. TA 07 2016 C04

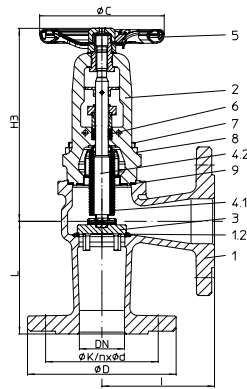
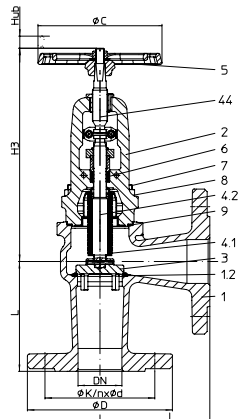
Considered standards: • EN 13709 (1.0619+N)

Plug design: V-port plug with marginal seat standard

At high differential pressures a balancing plug is necessary! (refer to page 21)

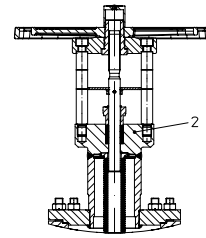
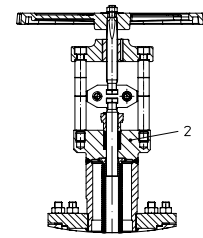
Bonnet DN200
One-piece stem

Bonnet DN200
Two-piece stem

Parts				Fig. 34. / 35.147....153 One-piece stem	Fig. 34. / 35.147....154 Two-piece stem
Pos.	Sp.p.	Description			
1		Body	GP240GH+N, 1.0619+N		
1.2		Seat	G19 9 NbSi, 1.4551		
2	x (Bonnet, opt.)	Bonnet	≤DN150: GP240GH+N, 1.0619+N / ≥DN200: P250 GH, 1.0460; P235GH-TC1, 1.0345; P265 GH, 1.0425		
+ 4.1		Bellows seal	X6CrNiMoTi17 12 2, 1.4571		
+ 4.2		Stem	X6CrNiMoTi17 12 2, 1.4571		
+ 6		Packing ring	Pure graphite		
+ 44		Stem, top	--	X39CrMo17-1+QT, 1.4122+QT	
3	x	Plug	≤DN150: X20Cr13+QT, 1.4021+QT (hardened) ≥DN200: P265GH, 1.0425 / Stellite 21		
5	x	Handwheel	≤DN125: St (cataphoretic coating) / ≥DN150: EN-GJS-400-15, EN-JS1030 (epoxy-coating)		
7		Stud	25CrMo4, 1.7218		
8		Hexagon nut	C35E, 1.1181		
9	x	Gasket	Pure graphite (with CrNi-grooved)		
L Spare parts					

DN	15	20	25	32	40	50	65	80	100	125	150	200	250	300
----	----	----	----	----	----	----	----	----	-----	-----	-----	-----	-----	-----

Face-to-face dimension CTF series 8 acc. to DIN EN 558													Standard-flange dimensions refer to page 25		
l	(mm)	90	95	100	105	115	125	145	155	175	200	225	275	325	375

Dimensions															
H3 (One-piece stem)	(mm)	210	210	215	215	255	255	275	350	420	450	510	720	835	915
H3 (Two-piece stem)	(mm)	225	225	225	225	275	275	310	365	465	500	545	745	835	915
ØC (One-piece stem)	(mm)	125	125	125	125	150	150	175	225	300	300	400	520	520	520
ØC (Two-piece stem)	(mm)	140	140	140	140	160	160	180	225	300	300	400	520	520	520
Travel	(mm)	6	6	8	8	13	13	16	20	25	32	40	50	70	80
Kvs-value	(m³/h)	5,5	8	12,5	17	28	42	80	100	155	245	370	530	850	1140
Zeta-value	--	2,7	4	4	5,8	5,2	5,7	4,5	6,5	6,6	6,5	5,9	9,1	8,6	10

Zeta-value ... range of tolerance for Kvs-values acc. to VDI/VDE 2173

Weights															
34. / 35.147	(kg)	5,2	7	7,5	8,3	11,1	14,2	20,3	27	46,5	59	67	180	270	347

Information / restriction of technical rules need to be observed!

Operating and installation instructions can be downloaded at www.ari-armaturen.com.

A production allowance acc. to TRB 801 No. 45 exists

The engineer, designing a system or a plant, is responsible for the selection of the correct valve.

Resistance and fitness must be verified (contact manufacturer for information, refer to Product overview and Resistance list).

ARI-FABA®-Supra I

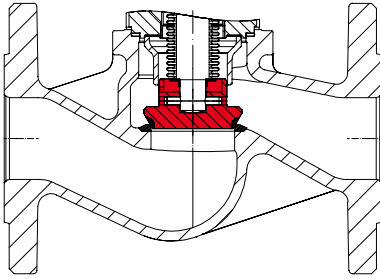

Isolation plug with marginal seat; stellited seat and plug

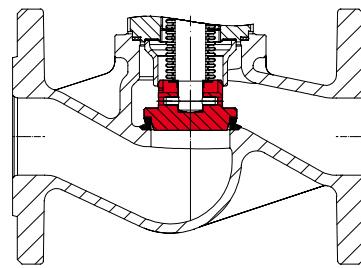

Plug with soft seal
Max. operating temperature 200°C at PTFE + 25% carbon

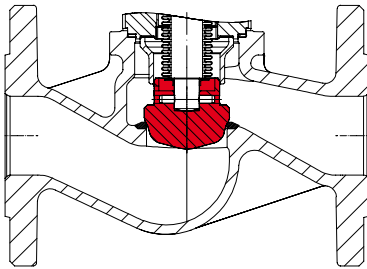

Regulating plug with marginal seat

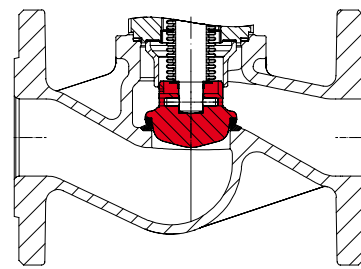

Regulating plug with soft seal
Max. operating temperature 200°C at PTFE + 25% carbon

ARI-FABA®-Supra C

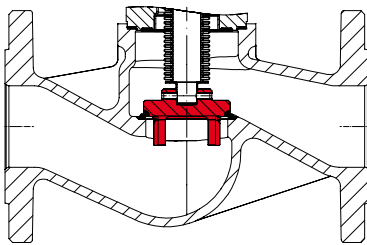

V-port plug with marginal seat, stellited

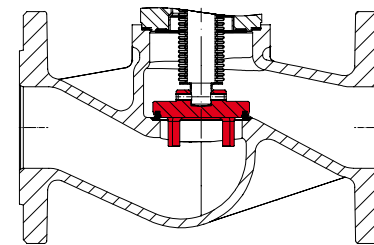

V-port plug with soft seal
Max. operating temperature 200°C at PTFE + 25% carbon

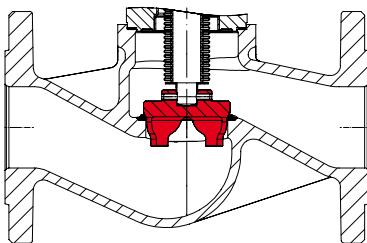

V-port regulating plug with marginal seat

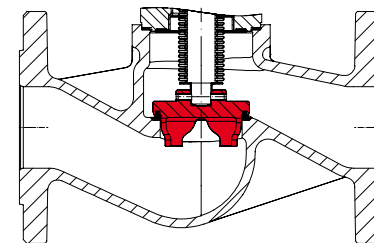

V-port regulating plug with soft seal
Max. operating temperature 200°C at PTFE + 25% carbon

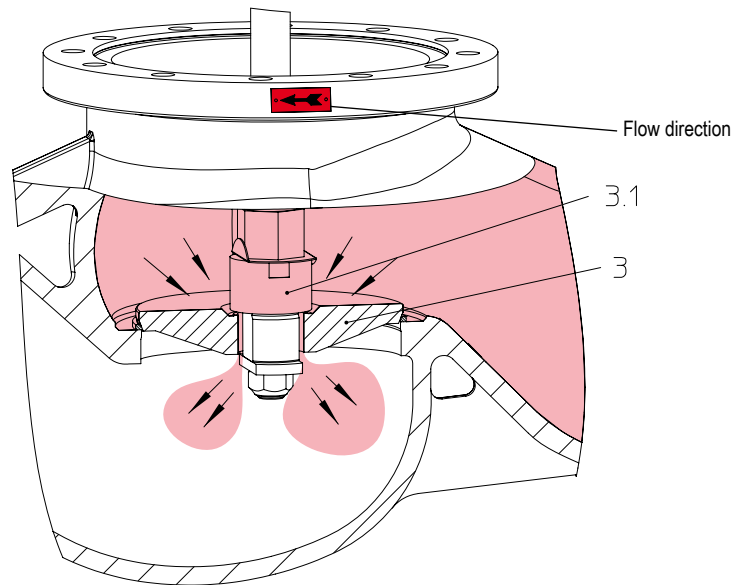

Balancing plug
(Standard: DN15 - 300 with marginal seat, from DN350 with flat seat)

Valves with balancing plugs have to be installed with medium flowing over the plug (3) as indicated by flow direction arrow on valve body.

Working principles:

When the valve is closed, anticlockwise rotation of the hand wheel lifts the pilot plug (3.1) off the larger balancing plug (3).

This allows the medium to pass through the plug and equalizes the pressure of the medium under the plug (3). After the pressures have been equalized within the valves stated in the table, the valve can be opened by turning the valve further with normal manual force.

Balancing plugs are fully effective only in closed systems.

The pressures of the medium on either side of the plug can not be equalized if the medium is discharged into open air.

A bypass line or some other arrangement is necessary if too much time is required for pressure equalization owing to the volume in the piping system.

ARI-stop valves with differential pressures exceeding the following pressures, have to be fitted with pressure balancing plugs

DN		125	150	200	250	300	350	400	500
Gauge press. (ΔP)	(bar)	25	21	14	9	6	4,5	3,5	1,5

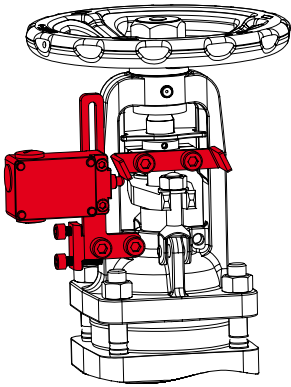

Limit switch

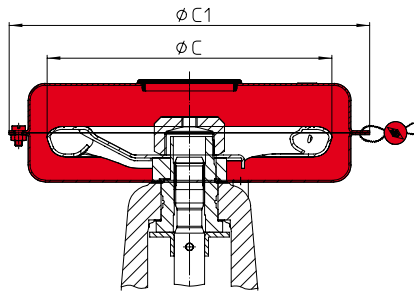

Hood valve acc.to DIN EN 12828
(tamper-proof handwheel cover,
only construction with one-piece stem)

Size	DN (mm)	ØC (mm)	ØC1 (mm)
I	15-50	125	170
II	65-80	150	190
III	100-150	225	330

Handwheel-Ø from DN 65 reduced!

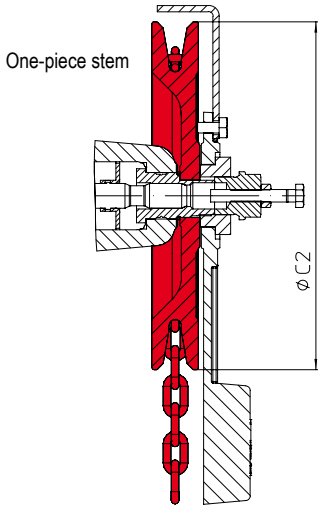

One-piece stem

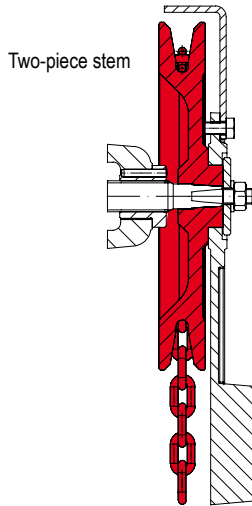

Two-piece stem

Chain wheel

DN (mm)	ØC2 (mm)	Weight (kg)
15-32	180	2,5
40-80	220	7
100-150	260	8,9
200-400	300	11

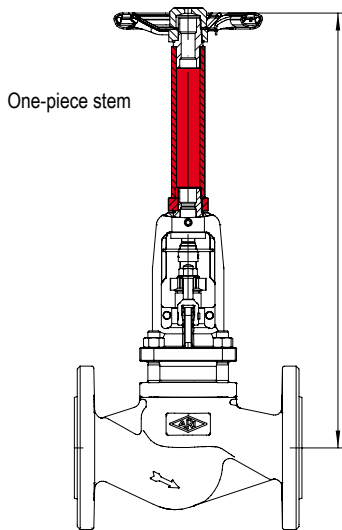

One-piece stem

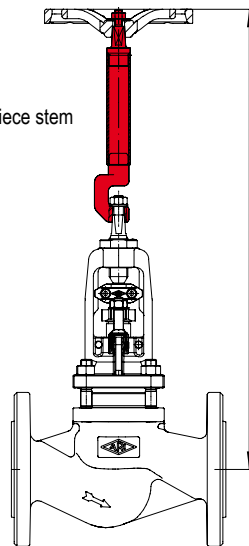

Two-piece stem

Stem extension (please specify height in your order)

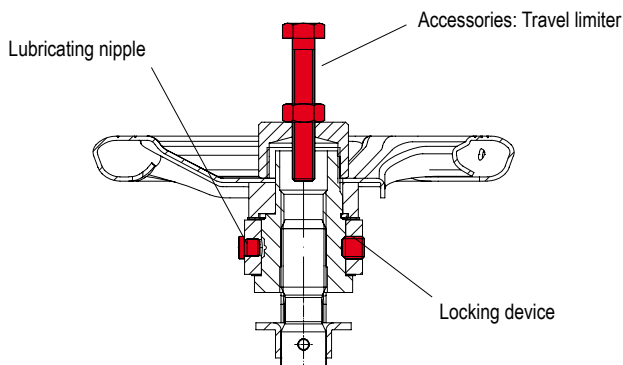

Travel limiter
(Accessories are not included !)

DN (mm)	Hexagon bolt (M x mm)
15-80	M8 x 55
100	M12 x 70
125-150	M12 x 80
200	M12 x 100
250-300	M12 x 120
350-400	M16 x 160

Lubricating nipple / Locking device / Travel limiter (only construction with one-piece stem)

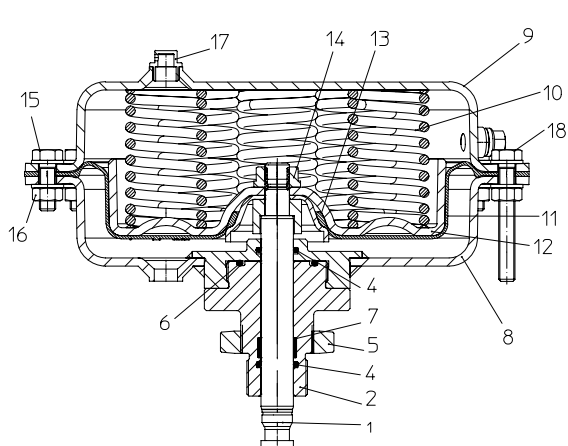
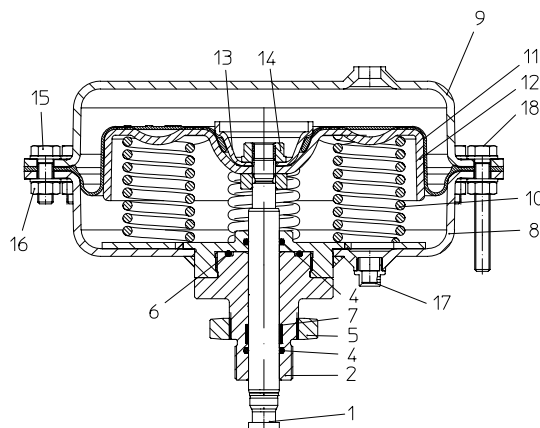
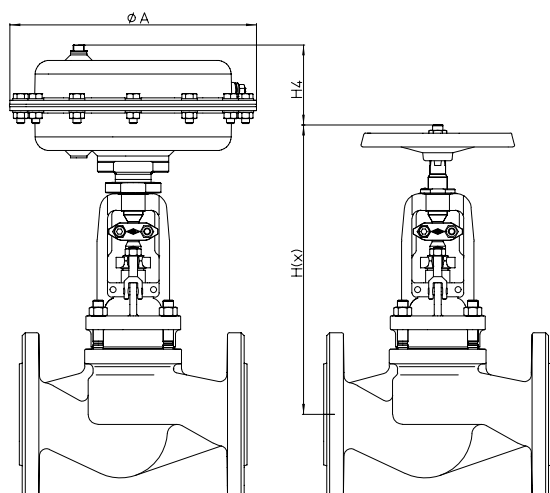
Pneumatic actuator ARI-FA

Spring closes (Extended stem on air failure)

Spring opens on air failure (Retracted stem on air failure)

Important:

The pneumatic actuator ARI-FA can be combined with all ARI-FABA-Supra versions with two-piece stem!

Max. medium temperatur in the valve 250°C !

Not aplicable for design with balancing plugs !

Parts			
Pos.	Sp.p.	Description	Material
1		Stem	X20Cr13+QT, 1.4021+QT
2		Head	X20Cr13+QT, 1.4021+QT
4	x	O-ring	NBR
5		Lock nut	11SMn30+C, 1.0715+C
6	x	O-ring	NBR
7	x	Guiding band	PTFE -+25%C
8		Lower diaphragm casing	DD13+QT, 1.0335+QT (powder coated)
9		Upper diaphragm casing	DD13+QT, 1.0335+QT (powder coated)
10	x	Spring	FDSiCr
11	x	Rolling diaphragm	NBR + webbing
12		Diaphragm plate	DD13+QT, 1.0335+QT (Fe/Zn12B)
13		Diaphragm flange	DD13+QT, 1.0335+QT (Fe/Zn12B)
14	x	Collar nut with sealing ring	8-A2B
15		Hexagon bolt	8.8-A2B
16		Hexagon nut	8-A2B
17	x	Vent plug	Polyethylene
		L Spare parts	

Type of actuator		FA160	FA250	FA400	FA800
Ø A	(mm)	210	250	300	405
H(x)	(mm)	refer to page 2 - 19			
max. H4	(mm)	90	105	120	165
max. pressure	(bar)	6	6	6	6
Weight (Actuator)	(kg)	6,5	9	17	50

max. permissible closing pressures on flow-to-open P2 = 0.
 Observe regulations, refer to page 25.

DN		15	20	25	32	40	50	65	80	100	125	150	
Travel		(mm)	6	6	8	8	13	13	16	20	25	32	40
FA160 Spring closes (Extended stem on air failure)	Air supply pressure min. (bar) ¹⁾	4 (bar)	40	40	26,7	18							
		4,5 (bar)				40	20,5	11,1	1,6				
		4,5 (bar)					40	31	14,8	6,5	1,4		
		5 (bar)									17,4	8,9	4,3

DN		15	20	25	32	40	50	65	80	100	125	150	
Travel		(mm)	6	6	8	8	13	13	16	20	25	32	40
FA160 Spring opens (Retracted stem on air failure)	Air supply pressure min. (bar) ¹⁾	3 (bar)	40	40	21,1	13,7							
		4 (bar)	40	40	40	31,9							
		5 (bar)	40	40	40	40							
		6 (bar)	40	40	40	40							
FA250 Spring opens (Retracted stem on air failure)	Air supply pressure min. (bar) ¹⁾	3 (bar)			38,4	13,8	6,9						
		4 (bar)				40	30	17,3	6,2				
		5 (bar)				40	40	27,8	12,5				
		6 (bar)				40	40	38,2	18,7				
FA400 Spring opens (Retracted stem on air failure)	Air supply pressure min. (bar) ¹⁾	3 (bar)						9,6	3,9				
		4 (bar)							19,6	10,5	4,7		
		5 (bar)							29,6	17,1	9		
		6 (bar)							39,5	23,8	13,2		
FA800 Spring opens (Retracted stem on air failure)	Air supply pressure min. (bar) ¹⁾	3 (bar)								10,4	4,5	1,8	
		4 (bar)								18,9	10	5,6	
		5 (bar)									27,5	15,5	9,4
		6 (bar)									36	21	13,2

¹⁾Air supply pressure max. to actuator: 6 bar

DN		15	20	25	32	40	50	65	80	100	125	150	200	250	300	350	400	500	
Standard-flange dimensions																			
Flanges acc. to DIN EN 1092-1/-2 (Flange holes / -thickness tol. acc. to DIN 2533/2544/2545)																			
PN25	ØD	(mm)	95	105	115	140	150	165	185	200	235	270	300	360	425	485	555	620	730
	ØK	(mm)	65	75	85	100	110	125	145	160	190	220	250	310	370	430	490	550	660
	n x Ød	(mm)	4x14	4x14	4x14	4x18	4x18	4x18	8x18	8x18	8x22	8x26	8x26	12x26	12x30	16x30	16x33	16x36	20x36
PN40	ØD	(mm)	95	105	115	140	150	165	185	200	235	270	300	375	450	515	580	660	755
	ØK	(mm)	65	75	85	100	110	125	145	160	190	220	250	320	385	450	510	585	670
	n x Ød	(mm)	4x14	4x14	4x14	4x18	4x18	4x18	8x18	8x18	8x22	8x26	8x26	12x30	12x33	16x33	16x36	16x39	20x42

Pressure-temperature-ratings	Intermediate values for max. permissible operational pressures can be determined by linear interpolation of the given temperature / pressure chart.
-------------------------------------	---

acc. to manufacturers standard			-60°C to <-10°C ¹⁾	-10°C to 120°C	150°C	200°C	250°C	300°C	350°C	400°C	450°C
1.0619+N	25	(bar)	18,7	25	23,9	22	20	17,2	16	14,8	8,2
1.0619+N	40	(bar)	30	40	38,1	35	32	28	25,7	23,8	13,1
1.0460	25	(bar)	18,7	25	23,9	22	20	17,2	16	14,8	10
1.0460	40	(bar)	30	40	38,1	35	32	28	25,7	23,8	16

acc. to DIN EN 1092-1			-60°C to <-10°C ¹⁾	-10°C to 100°C	150°C	200°C	250°C	300°C	350°C	400°C	450°C
1.4408	25	(bar)	25	25	22,7	21	19,8	18,5	17,8	17,1	--
1.4408	40	(bar)	40	40	36,3	33,7	31,8	29,7	28,5	27,4	--
1.4581	25	(bar)	12,5	25	24,5	23,3	22,1	20,8	20,1	19,5	--
1.4581	40	(bar)	20	40	39,2	37,3	35,4	33,3	32,1	31,2	--

¹⁾ Studs and nuts made of A4-70 (at temperatures below -10°C)

Please indicate when ordering

- Figure-No.
- Nominal pressure
- Nominal diameter
- Special design / accessories

Example:

Figure 35.146; Nominal pressure PN40; Nominal diameter DN100.

L = Face-to-face dimension

Edge shaping acc. to DIN EN ISO 5817

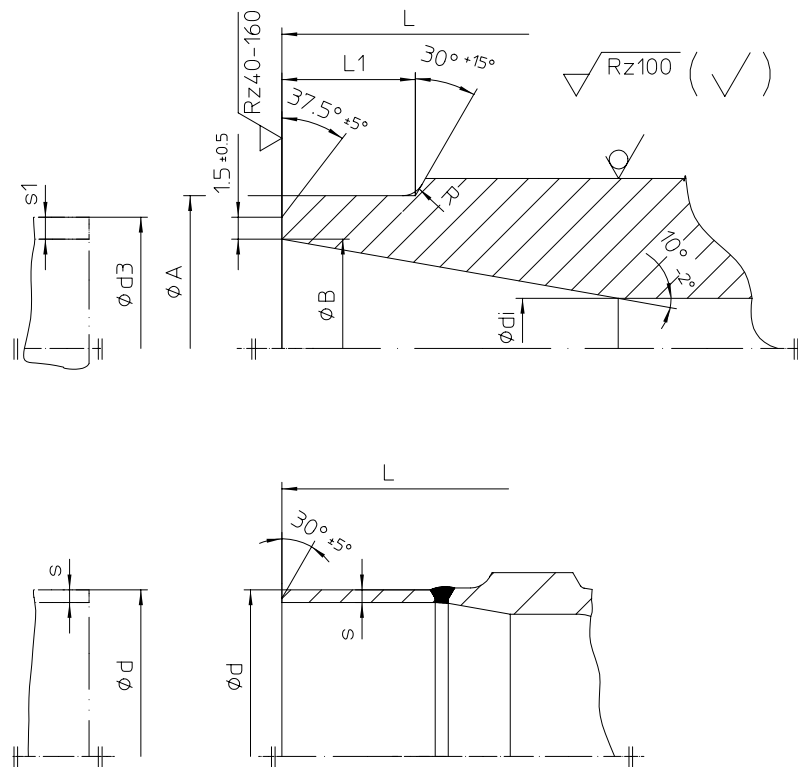

DN	15	20	25	32	40	50	65	80	100	125	150	200	250	300	350	400
----	----	----	----	----	----	----	----	----	-----	-----	-----	-----	-----	-----	-----	-----

Butt weld ends according to DIN EN 12627																	
L	(mm)	130	150	160	180	200	230	290	310	350	400	480	600	730	850	980	1100
ØA	(mm)	22	28	35	44	50	62	77	91	117	144	172	223	278	329	362	413
ØB	(mm)	17,3	22,3	28,5	37,2	43,1	53,9	68,9	80,9	104,3	130,7	157,1	204,9	257	307,9	338	384,4
Ødi	(mm)	15	20	25	32	40	50	65	80	100	125	150	200	250	300	330	375
R	(mm)	3	3	3	3	3	3	3	3	3	3	3	5	5	5	5	5
L1 (similar)	(mm)	10	10	10	10	10	10	10	12	14	18	20	20	25	33	45	45
Ød3	(mm)	21,3	26,9	33,7	42,4	48,3	60,3	76,1	88,9	114,3	139,7	168,3	219,1	273	323,9	355,6	406,4
s1	(mm)	2	2,3	2,6	2,6	2,6	3,2	3,6	4	5	4,5	5,6	7,1	8	8	8,8	11

Face-to-face dimension ETE series 1 according to DIN EN 12982.

Butt weld ends according to DIN EN 12627 Fig. 4.

Weld joint according to DIN EN 29692 code number 1.3.3.

The material used for ARI valves with butt weld ends are:

GP240GH+N, 1.0619+N acc. to DIN EN 10213-2,

P250GH, 1.0460 acc. to DIN EN 10222-2.

DN	15	20	25	32	40	50	65	80	100	125	150	200	250	300	350	400
----	----	----	----	----	----	----	----	----	-----	-----	-----	-----	-----	-----	-----	-----

Shoed ends of P235GH (Pipe connection Δ welding neck flanges)																	
Ød	(mm)	--	--	--	--	--	--	76,1	88,9	114,3	139,7	168,3	219,1	--	--	--	--
Øs	(mm)	--	--	--	--	--	--	2,9	3,2	3,6	4	4,5	6,3	--	--	--	--

The material used for ARI valves with shoed ends (DN 65-200) P235GH according to DIN EN 10216-2.

Based on our experience we recommend electric welding process for connecting valves or strainers with tubes or with each other.

Lime based electrodes with an appropriate composite material should be used as filler material for welding.

Gas welding should be avoided.

Due to the different material composition and material thickness of valves and tubes, gas welding is more susceptible to produce faults than electric welding (hardness cracks, coarse-grained structure).