

**RESILIENT SEAT GATE VALVE ISO PN16**



ISO 9001 : 2008



**Size :** DN 40 to DN 400  
**Ends :** ISO PN10/16 flanges  
**Min Temperature :** - 10°C  
**Max Temperature :** + 110°C with EPDM wedge  
**Max Pressure :** 16 Bars  
**Specifications :** Non rising stem  
Clockwise to close  
Full and total bore

**Materials :** Ductile iron body

## RESILIENT SEAT GATE VALVE ISO PN16

### SPECIFICATIONS :

- Full and total bore
- Stainless steel non rising stem
- Clockwise to close
- Sliding pad ( to facilitating the wedge movement ) up to DN200
- Ductile iron wedge EPDM or NBR coated
- No retention area
- Heel positioning
- NBR bonnet gasket
- Screws bonnet protected
- 3 NBR O ring on stem
- Possibility to change stem gasket under pressure
- Epoxy painting RAL 5005 color 250 µm thickness
- Dust-coat on stem
- ISO PN10/16 flanges R.F.

### USE :

- For water distribution
- Min and max Temperature Ts : - 10°C to + 110°C for ductile iron wedge EPDM coated **Ref. 180**
- Min and max Temperature Ts : - 10°C to + 70°C for ductile iron wedge NBR coated **Ref. 182**
- Max Pressure PN : 16 bars

### RANGE :

- Ductile iron body with ISO PN10/16 flanges R.F. and handwheel with EPDM wedge **Ref. 180** from DN 40 to DN 400
- Ductile iron body with ISO PN10/16 flanges R.F. and handwheel with NBR wedge **Ref. 182** from DN 40 to DN 300
- Possible with cap top ( option ) **Ref. 9801831-9801838**

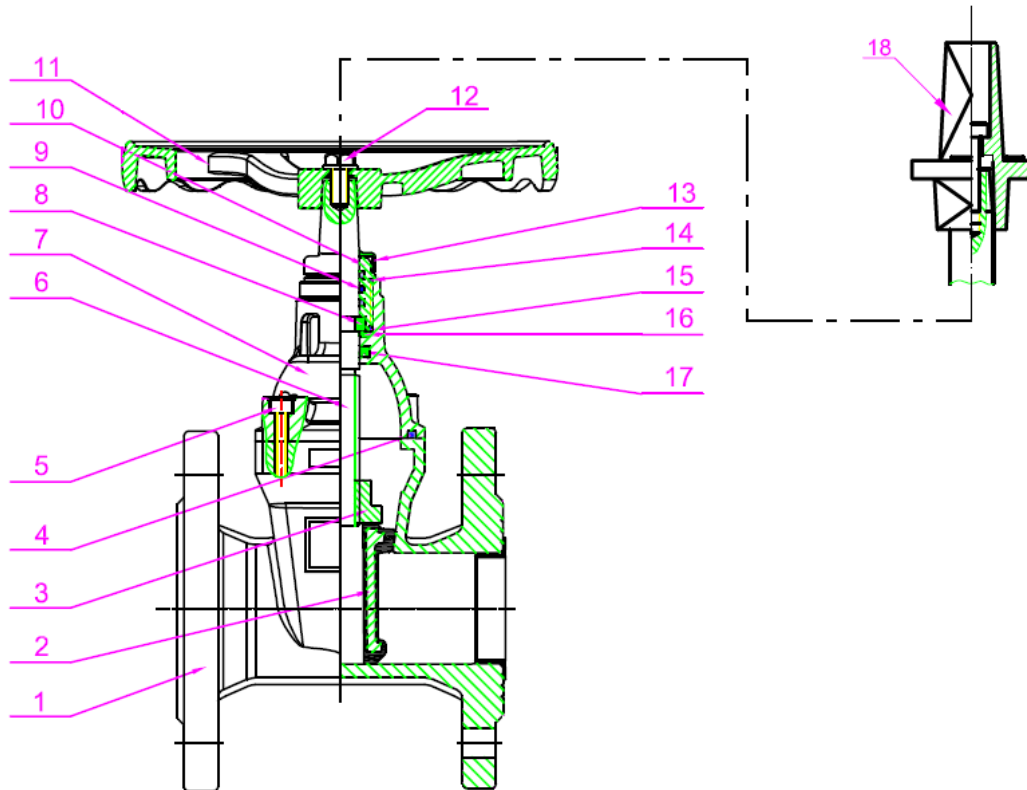

**RESILIENT SEAT GATE VALVE ISO PN16**
**MATERIALS :**

Item	Designation	Materials Ref.180	Materials Ref.182
1	Body	Ductile iron EN GJS-500-7	Ductile iron EN GJS-500-7
2	Wedge	Ductile iron EN GJS-500-7 + EPDM	Ductile iron EN GJS-500-7 + NBR
3	Stem nut	Brass CuZn40Pb3	Brass CuZn40Pb3
4	Gasket bonnet	NBR	NBR
5	Bonnet screw	Steel C35	Steel C35
6	Stem	SS 420	SS 420
7	Bonnet	Ductile iron EN GJS-500-7	Ductile iron EN GJS-500-7
8	Holding ring	Brass CuZn39Pb2	Brass CuZn39Pb2
9	O ring	NBR	NBR
10	Pusher nut	Brass CuZn39Pb2	Brass CuZn39Pb2
11	Handwheel	Ductile iron EN GJS-500-7	Ductile iron EN GJS-500-7
12	Handwheel screw	Steel Rst 37-2	Steel Rst 37-2
13	Dust-coat	NBR	NBR
14	O ring	NBR	NBR
15	O ring	NBR	NBR
16	Ring	Nylon 66	Nylon 66
17	Auto sealing ring	NBR	NBR
18	Cap top	Ductile iron EN GJS-500-7	Ductile iron EN GJS-500-7

**RESILIENT SEAT GATE VALVE ISO PN16**

HANDWHEEL VALVE SIZE ( in mm ) :

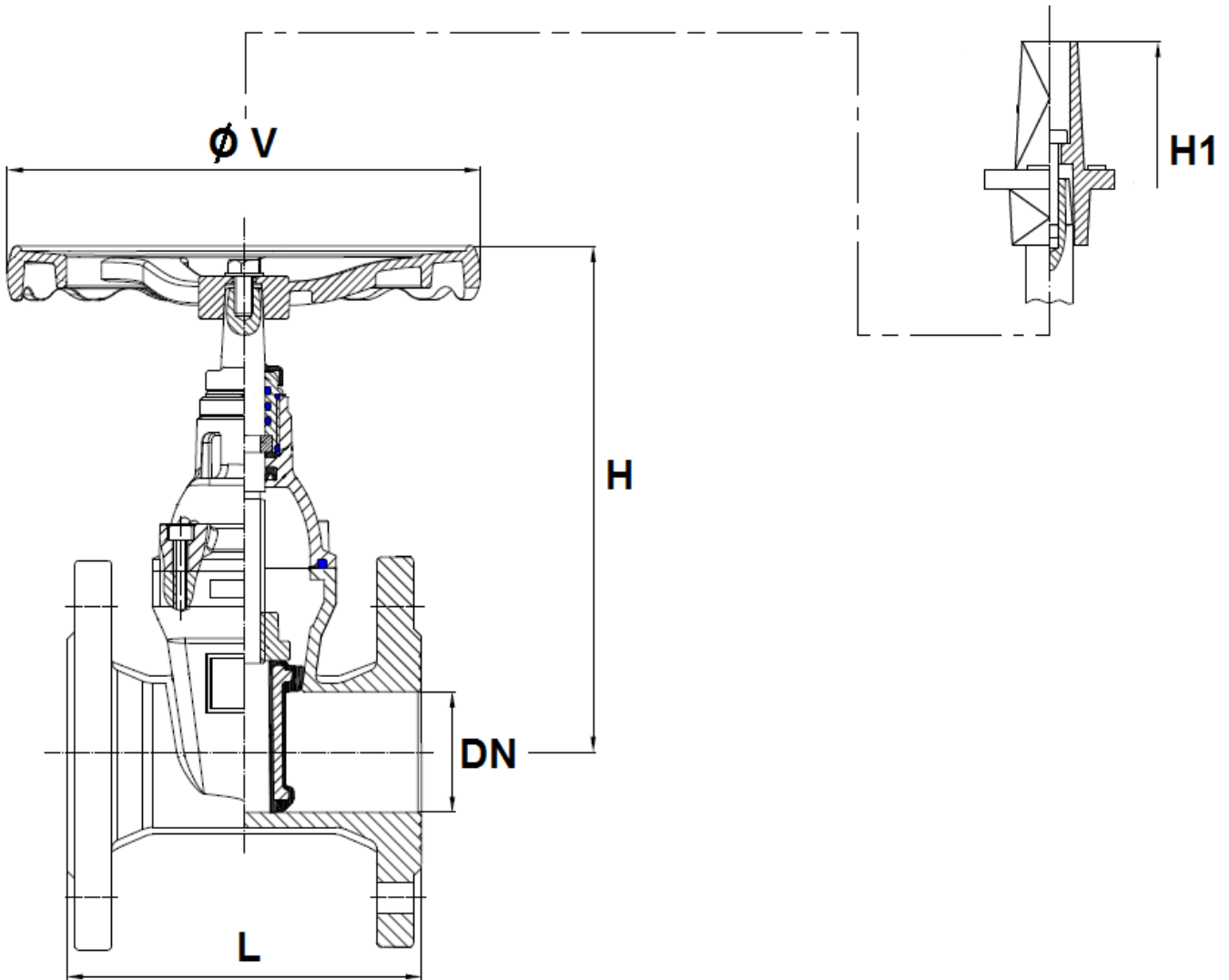

Ref.	DN	40	50	65	80	100	125	150	200	250	300	350	400
180/182	L	140	150	170	180	190	200	210	230	250	270	290	310
	H	190	215	235	265	315	350	385	485	600	680	810	890
	H1	280	285	300	320	390	430	470	560	680	770	900	1000
	$\varnothing V$	200	200	200	254	254	315	315	315	406	406	500	500
	Weight ( Kg )	7.38	8.83	12.12	13.32	19.65	23.12	32.08	53.9	79.39	107.31	185.82	236

**RESILIENT SEAT GATE VALVE ISO PN16**

CAP TOP VALVE SIZE ( in mm ) :

**DN 40 – 300**

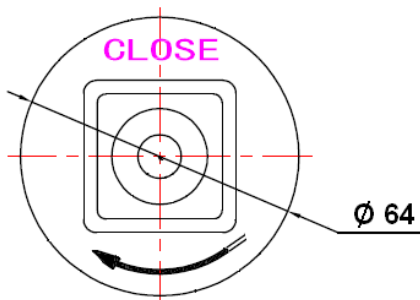
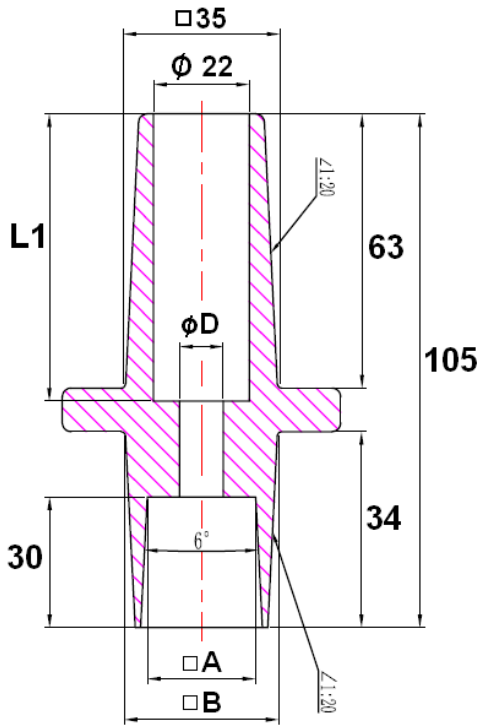

**DN 350 - 400**

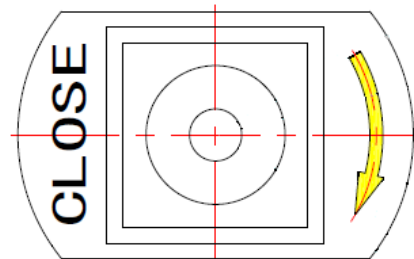
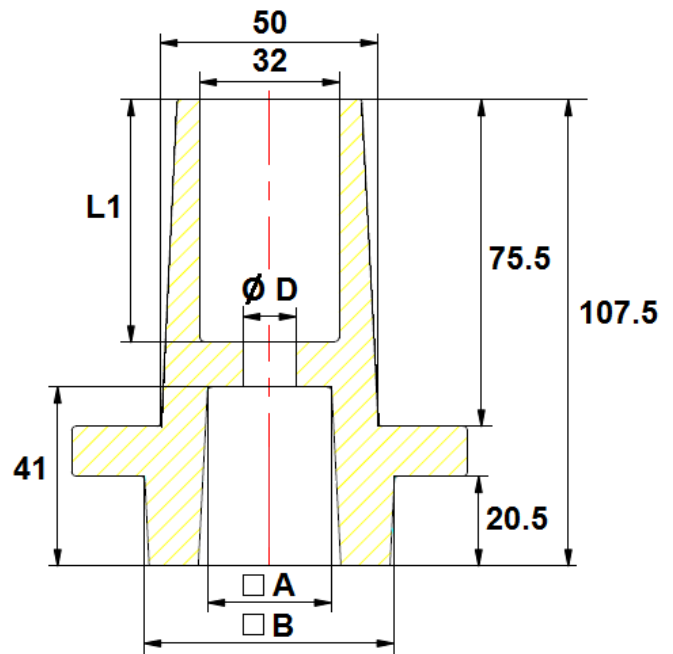

DN	40	50	65	80	100	125	150	200	250	300	350	400
A	14	14	14	17	17	19	19	19	24	24	28.5	28.5
B	34	34	34	34	34	36	36	36	42.5	42.5	57.5	57.5
L1	66	66	66	63	63	63	63	63	63	63	56	56
Ø D	10	10	10	10	10	10	10	10	12	12	12	12
Weight ( Kg )	0.7	0.7	0.7	0.6	0.6	0.6	0.6	0.6	0.7	0.7	0.8	0.8
Ref.	9801831	9801831	9801831	9801832	9801832	9801833	9801833	9801833	9801834	9801834	9801838	9801838

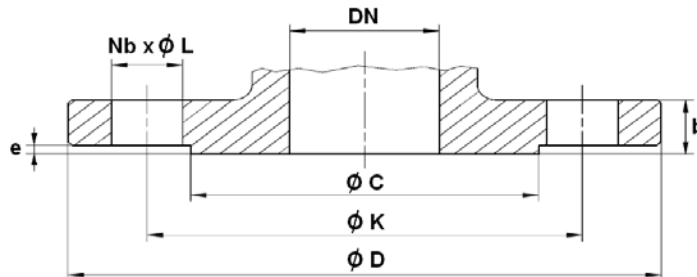
**RESILIENT SEAT GATE VALVE ISO PN16**
**FLANGES SIZE ISO PN10 ( in mm ) :**

DN	40	50	65	80	100	125	150	200	250	300	350	400
Ø C	84	99	118	132	156	184	211	266	319	370	429	480
Ø D	150	165	185	200	220	250	285	340	405	460	520	580
Ø K	110	125	145	160	180	210	240	295	350	400	460	515
Nb x Ø L	4 x 19	4 x 19	4 x 19	8 x 19	8 x 19	8 x 19	8 x 23	8 x 23	12 x 23	12 x 23	16 x 23	16 x 28
b	19	19	19	19	19	19	19	20	22	24.5	26.5	28
e	3	3	3	3	3	3	3	3	3	4	4	4
Ref. 180	180040	180050	180065	180080	180100	180125	180150	180200	180250	180300	180350	180400
Ref. 182	182040	182050	182065	182080	182100	182125	182150	182200	182250	182300	-	-

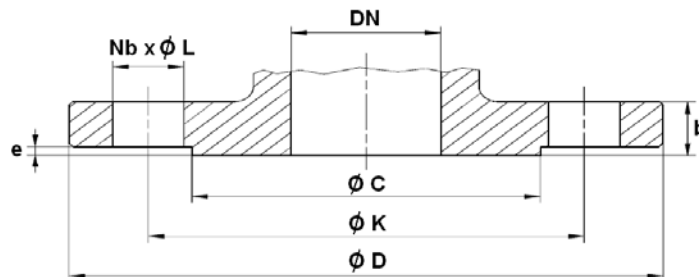
**FLANGES SIZE ISO PN16 ( in mm ) :**

DN	200	250	300
Ø C	266	319	370
Ø D	340	405	460
Ø K	295	355	410
Nb x Ø L	12 x 23	12 x 28	12 x 28
b	20	22	24.5
e	3	3	4
Ref. 180	180201	180251	180301
Ref. 182	182201	182251	182301

**RESILIENT SEAT GATE VALVE ISO PN16**
**TORQUE VALUES ( in Nm without safety coefficient ) :**

DN	40	50	65	80	100	125	150	200	250	300	350	400
Torque ( Nm )	35	40	45	50	55	70	75	100	160	245	350	360

**NUMBER OF CYCLES TO CLOSE OR OPEN THE VALVE :**

DN	40	50	65	80	100	125	150	200	250	300	350	400
Number of cycles	13	14.5	18.75	21.5	21.5	24.5	30	34	45.25	49.75	55	61

**STANDARDS :**

- Fabrication according to ISO 9001 :2008
- Designing according to DIN 3352.4, EN 1074-1 and EN 1074-2
- Tests according to EN 1074 and EN 12266
- DIRECTIVE 97/23/CE : Concerned by article 3, § 3
- Length according to EN 558 series 14 ( DIN 3202 F4 )
- Flanges according to EN 1092-2 PN10/16
- English water agreement WRAS N° 0812501 for the wedge EPDM coated
- Approval certificate Russian **GOST-R**

**ADVICE :** Our opinion and our advice are not guaranteed and SFERACO shall not be liable for the consequences of damages. The customer must check the right choice of the products with the real service conditions.

**RESILIENT SEAT GATE VALVE ISO PN16****INSTALLATION INSTRUCTIONS****GENERAL GUIDELINES :**

- Ensure that the valves to be used are appropriate for the conditions of the installation (type of fluid, pressure and temperature).
- Be sure to have enough valves to be able to isolate the sections of piping as well as the appropriate equipment for maintenance and repair.
- Ensure that the valves to be installed are of correct strength to be able to support the capacity of their usage.
- **Installation of all circuits should ensure that their function can be automatically tested on a regular basis (at least two times a year).**

**INSTALLATION INSTRUCTIONS :**

- **Before installing the valves, clean and remove any objects from the pipes** (in particular bits of sealing and metal) which could obstruct and block the valves.
- **Ensure that both connecting pipes either side of the valve (upstream and downstream) are aligned (if they're not, the valves may not work correctly).**
- **Make sure that the two sections of the pipe (upstream and downstream) match, the valve unit will not absorb any gaps. Any distortions in the pipes may affect the tightness of the connection, the working of the valve and can even cause a rupture.** To be sure, place the kit in position to ensure the assembling will work.
- **If sections of piping do not have their final support in place, they should be temporarily fixed. This is to avoid unnecessary strain on the valve.**
- Tighten the bolts in cross.
- It's recommended to operate the valve ( open and close ) 1 to 2 times per year