

Gate Valve

ECOLINE GT 40

PN 10-40
DN 50-600
Bolted bonnet
Flanged ends

Type Series Booklet



Legal information/Copyright

Type Series Booklet ECOLINE GT 40

KSB Aktiengesellschaft

All rights reserved. The contents provided herein must neither be distributed, copied, reproduced, edited or processed for any other purpose, nor otherwise transmitted, published or made available to a third party without KSB's express written consent.

Subject to technical modification without prior notice.

© KSB Aktiengesellschaft Frankenthal 2012

Gate Valves

Gate Valves with Bolted Bonnet

ECOLINE GT 40

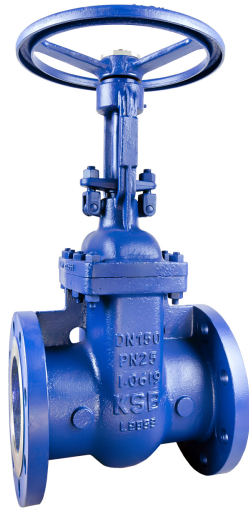

Main applications

- Boiler recirculation
- Cooling circuits
- Condensate transport
- Petrochemical industry
- Process engineering
- Heat recovery systems
- Sugar industry
- Mining
- Descaling units
- Paper and cellulose industry
- Snow-making systems

Fluids handled

- Water
- Steam
- Gas
- Oil
- Other fluids on request.

Operating data

Operating properties

Characteristic	Value
Nominal pressure	PN 10-40
Nominal size	DN 50-600
Max. permissible pressure	40 bar
Max. permissible temperature	400 °C

Selection as per pressure/temperature ratings (⇒ Page 4)

Body materials

Overview of available materials

Material	Material number	Temperature limit
GP 240 GH	1.0619	Up to 400 °C

Other materials on request.

Design details

Design

- Bolted bonnet
- Non-rotating stem with external screw
- Back seat
- Flexible wedge
- Yoke head suitable for mounting electric and pneumatic actuators (DIN ISO 5210)
- The valves satisfy the safety requirements of Annex I of the European Pressure Equipment Directive 97/23/EC (PED) for fluids in Groups 1 and 2.
- The valves do not have a potential internal source of ignition and can be used in potentially explosive atmospheres, Group II, category 2 (zones 1+21) and category 3 (zones 2+22) to ATEX 94/9/EC.

Variants

- Stem protecting tube
- Stem protecting tube with position indicator
- Stem protecting tube with position switch
- Bypass
- Actuator installation kit
- Spur gear
- Bevel gear
- Electric actuators
- Seat/disc interface made of wear-resistant and corrosion-proof Stellite
- TA-Luft-compliant model for applications to VDI 2440 up to 400 °C (max.)
- Other flange designs

Product benefits

- Additional features ensure safe sealing to atmosphere:
 - Bonnet gasket fully confined to prevent creep (PN 40).
 - Graphite gland packing with packing end rings.
- Additional safety and blow-out protection by standard back seat.
- Long service life and high functional reliability
 - Of the gland packing due to non-rotating stem with burnished shank.
 - Hard-faced seat/disc interface made of wear-resistant and corrosion-proof materials.
- Threaded bush free from non-ferrous metals, for versatile application.

Related documents

- Operating manual 7367.8

On all enquiries/orders please specify

- | | |
|---|--|
| <ol style="list-style-type: none"> 1. Type 2. Nominal pressure 3. Nominal size 4. Operating pressure 5. Differential pressure 6. Operating temperature 7. Material | <ol style="list-style-type: none"> 8. Fluid handled 9. Flow rate 10. Pipe connection 11. Variants 12. Number of type series booklet <p>Always indicate the original serial number and the year of construction when ordering spare parts.</p> |
|---|--|

Pressure/temperature ratings

Permissible operating pressures in bar at a temperature of °C (to EN 1092-1)

Nominal pressure	Material	RT ¹⁾	100	150	200	250	300	350	400
10	GP 240 GH	10.0	9.2	8.8	8.3	7.6	6.9	6.4	5.9
16		16.0	14.8	14.0	13.3	12.1	11.0	10.2	9.5
25		25.0	23.2	22.0	20.8	19.0	17.2	16.0	14.8
40		40.0	37.1	35.2	33.3	30.4	27.6	25.7	23.8

¹⁾ RT: room temperature (-10 °C to +50 °C)

Materials

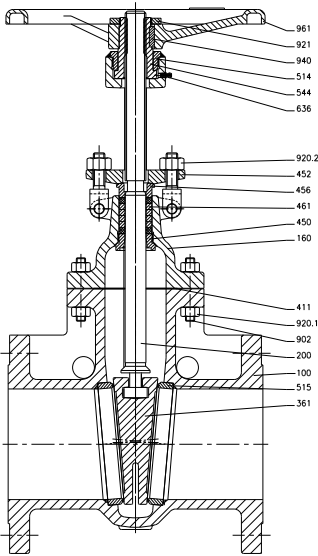

PN 10-25
DN 50-300

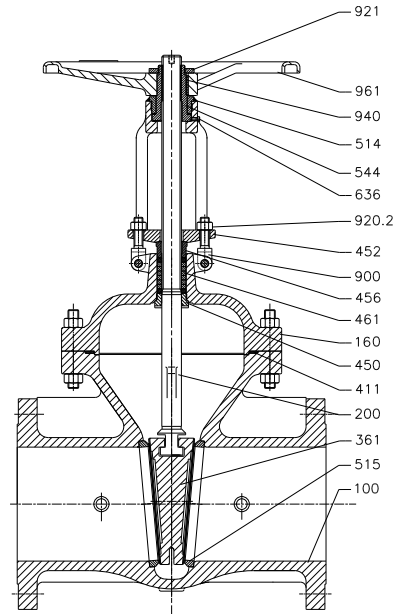

PN 40
DN 50-300

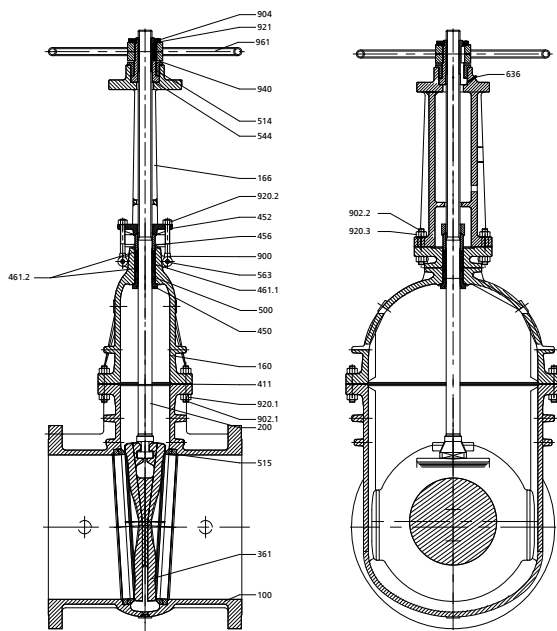

PN 10-25
DN 350-600

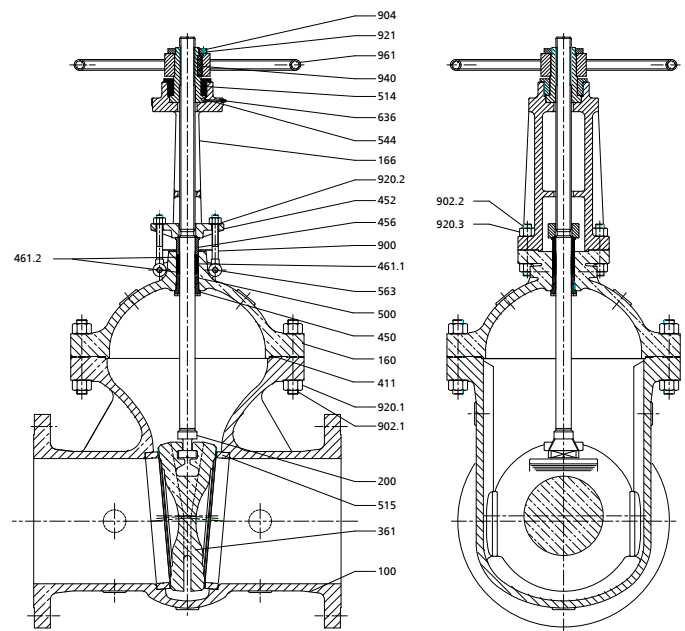

PN 40
DN 350-400

Overview of available materials

Part No.	Description	Material	Material number	Note
100	Body	GP 240 GH	1.0619	
160	Bonnet	GP 240 GH	1.0619	
166	Yoke	A 216 WCB		Equivalent DIN material: GP 240 GH
200	Stem	A 182 F6A		Equivalent DIN material: X 10 Cr 13
361	Flexible wedge	A 216 WCB		Equivalent DIN material: GP 240 GH
Seat/disc interface	Body	Stellite 6		
	Wedge halves	13 % Cr		
411	Joint ring	SS316/graphite		
450	Back seat	A 276 410		Equivalent DIN material: X 12 Cr 13

Part No.	Description	Material	Material number	Note
452	Gland follower	A 216 WCB		Equivalent DIN material: GP 240 GH
456	Gland bush	A 276 410		Equivalent DIN material: X 12 Cr 13
461.1	Packing ring	Graphite		
461.2		Graphite		Packing end rings
500	Neck ring	A 276 410		≥ DN400
514	Yoke bush	A 29 M 1035		Equivalent DIN material: C 35
515	Seat ring	A 105		P 250 GH
544	Threaded bush	A 439 D-2		Free from non-ferrous metals
563	Grooved pin	A 29 M 1035		Equivalent DIN material: C 35
636	Lubricating nipple	SS304		
900	Eyebolt	A 307-B		Equivalent DIN material: St 50.11
902.1/.2	Stud	A 193 B7		Equivalent DIN material: 24 CrMo 5
904	Grub screw			
920.1/.2/.3	Hexagon nut	A 194 2H		Equivalent DIN material: C 35
921	Keywayed nut	A 29 M 1035		Equivalent DIN material: C 35
940	Key	A 29 M 1035		Equivalent DIN material: C 35
961	Handwheel	QT400-18		≤ DN 350, nodular cast iron
		A 29 M 1020		> DN 350 Equivalent DIN material: C 22

Variants

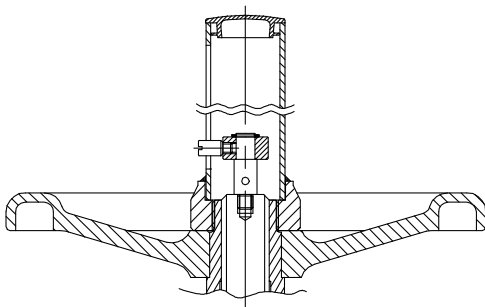

Stem protecting tube with position indicator

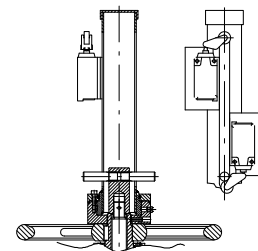

Stem protecting tube with position switch(es)

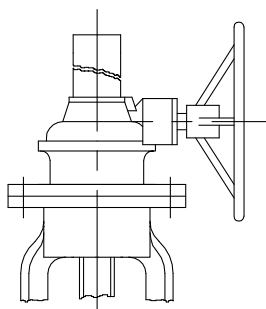

Gearbox

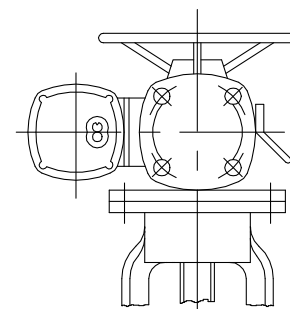

Electric actuators

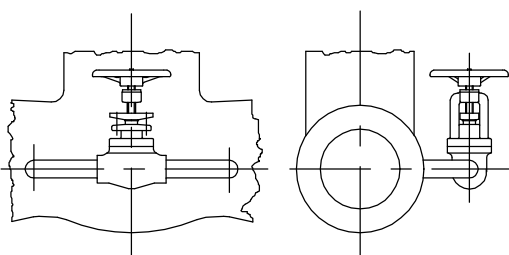

Bypass

Dimensions

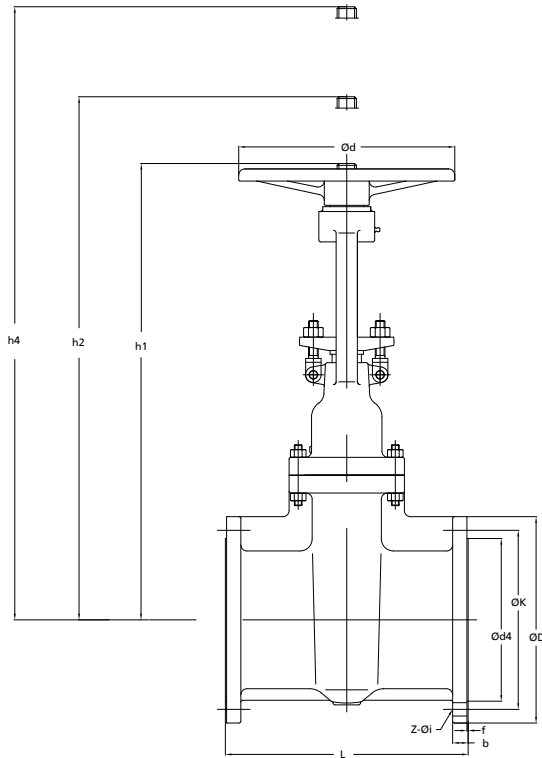

Dimensions in mm

PN	DN	l	Ø D	Ø k	No. of bolt holes z	Bolt hole dia. i	Ø d ₄ x f	b	h ₁	h ₂ ²⁾	h ₄ ³⁾	Ø d	[kg]
10	50	250	165	125	4	18	102 x 2	19	300	355	427	203	18
	65	270	185	145	8	18	122 x 2	18.5	350	433	505	254	26
	80	280	200	160	8	18	138 x 2	22	355	437	552	254	28
	100	300	220	180	8	18	158 x 2	22	425	530	670	254	39
	125	325	250	210	8	18	188 x 2	23	559	705	845	356	60
	150	350	285	240	8	22	212 x 2	23	597	763	953	356	103
	200	400	340	295	8	22	268 x 2	25.5	745	970	1186	356	132
	250	450	395	350	12	22	320 x 2	27.5	890	1155	1400	457	206
	300	500	445	400	12	22	370 x 2	27	1074	1395	1795	508	301
	350	550	505	460	16	22	430 x 2	27	1295	1660	1950	508	443
	400	600	565	515	16	26	482 x 2	27	1493	1903	2423	610	619
450	650	615	565	20	26	532 x 2	29.5	1583	2051	2544	700	753	
500	700	670	620	20	26	585 x 2	29.5	1748	2260	2665	800	889	
600	800	780	725	20	30	685 x 2	35.5	2051	2669	3169	800	1349	
16	50	250	165	125	4	18	102 x 2	19	300	355	427	203	18
	65	270	185	145	8	18	122 x 2	18.5	350	433	505	254	26
	80	280	200	160	8	18	138 x 2	22	355	437	552	254	28
	100	300	220	180	8	18	158 x 2	22	425	530	670	254	40
	125	325	250	210	8	18	188 x 2	23	559	705	845	356	60
	150	350	285	240	8	22	212 x 2	23	597	763	953	356	104
	200	400	340	295	12	22	268 x 2	25.5	745	970	1186	356	133
	250	450	405	355	12	26	320 x 2	27.5	890	1155	1400	457	210
	300	500	460	410	12	26	378 x 2	29	1074	1395	1795	508	307
	350	550	520	470	16	26	438 x 2	31	1295	1660	1950	508	430
400	600	580	525	16	30	490 x 2	33	1493	1903	2423	610	629	
450	650	640	585	20	30	550 x 2	41.5	1583	2051	2544	700	789	

2) Open

3) Vertical clearance for removal

PN	DN	l	ø D	ø k	No. of bolt holes z	Bolt hole dia. i	ø d ₄ x f	b	h ₁	h ₂ ²⁾	h ₄ ³⁾	ø d	[kg]
	500	700	715	650	20	33	610 x 2	45.5	1748	2260	2665	800	964
	600	800	840	770	20	36	725 x 2	57	2051	2669	3169	800	1467
25	50	250	165	125	4	18	102 x 2	21	300	355	427	203	19
	65	270	185	145	8	18	122 x 2	24	350	433	505	254	26
	80	280	200	160	8	18	138 x 2	26.5	355	437	552	254	32
	100	300	235	190	8	22	162 x 2	25	425	530	670	254	42
	125	325	270	220	8	26	188 x2	27	559	705	845	356	67
	150	350	300	250	8	26	218 x2	29	597	763	953	356	105
	200	400	360	310	12	26	278 x 2	31.5	745	970	1186	356	133
	250	450	425	370	12	30	335 x 2	33.5	890	1155	1400	457	235
	300	500	485	430	16	30	395 x 2	35.5	1074	1395	1795	508	338
	350	550	555	490	16	33	450 x 2	39.5	1295	1660	1960	508	484
	400	600	620	550	16	36	505 x 2	41.5	1493	1903	2423	610	707
	450	650	670	600	20	36	555 x 2	47.5	1583	2051	2519	700	847
40	500	700	730	660	20	36	615 x 2	49.5	1748	2260	2615	800	1025
	600	800	845	770	20	39	720 x 2	60.5	2051	2669	3169	800	1536
	50	250	165	125	4	18	102 x 2	21	300	355	427	203	19
	65	290	185	145	8	18	122 x 2	23.5	385	465	537	254	36
	80	310	200	160	8	18	138 x 2	26.5	400	486	601	254	43
	100	350	235	190	8	22	162 x 2	25	505	615	755	254	89
	125	400	270	220	8	26	188 x2	27	576	720	860	356	120
	150	450	300	250	8	26	218 x2	29.5	665	835	1025	356	128
	200	550	375	320	12	30	285 x 2	35.5	797	1022	1238	457	220
	250	650	450	385	12	33	345 x 2	39.5	970	1237	1627	508	368
	300	750	515	450	16	33	410 x 2	43.5	1104	1427	1872	508	489
	350	850	580	510	16	36	465 x 2	47.5	1366	1738	2238	610	847
400	950	660	585	16	39	535 x 2	51.5	1493	1920	2470	700	1145	

Mating dimensions - Standards

Face-to-face PN 10-25: EN 558-1/15
lengths: PN 40: EN 558-1/26
Flanges: Mating dimensions to DIN EN 1092-1
Flange facing: Type B

Other flange designs

- E.g. groove (type D), tongue (type C), recess (type F), spigot (type E) to EN 1092-1 at both ends
- Other flange designs on request

Installation instructions

The gate valves are designed for a max. differential pressure equal to the permissible operating pressure.

If a bypass line is required or requested for other reasons, an ECOLINE GL 800 globe valve as per type series booklet 7247.1240 should be used as bypass valve. The nominal size of the globe valve depends on the gate valve nominal size (see table).

Nominal size of bypass valve

Nominal size of gate valve	Nominal size of bypass valve
DN 150 - 200	DN 15
DN 250 - 350	DN 25
DN 400 - 600	DN 40

2) Open

3) Vertical clearance for removal



KSB Aktiengesellschaft

Bahnhofplatz 1 • 91257 Pegnitz (Germany)

Tel. +49 9241 71-0 • Fax +49 9241 71-1795

E-Mail: valves@ksb.com • www.ksb.com