

BRONZE GATE VALVE PN10/16

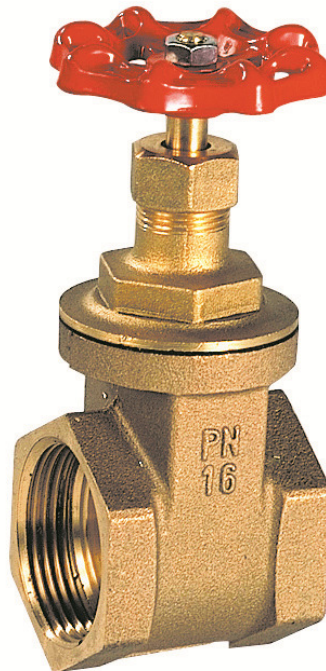

ISO 9001:2000



Size : DN 1/4" to 4"
Ends : Female - Female BSP
Min Temperature : -10°C
Max Temperature : + 80°C
Max Pressure : 16 Bars up to DN 2"
Specifications : Rotating non rising stem
Inside screw stem
Reduce bore

Materials : Bronze

BRONZE GATE VALVE PN10/16

SPECIFICATIONS :

- Reduce bore
- Rotating non rising stem
- Inside screw stem
- Bronze
- Single wedge disc
- Female / Female BSP cylindric
- PTFE packing

USE :

- Water distribution and watering
- Min and max Temperature Ts : - 10°C to + 80°C
- Max Pressure Ps : 16 bars up to DN2" , 10 bars over
- Do not use for firefighting networks

HEAD LOSS GRAPH :

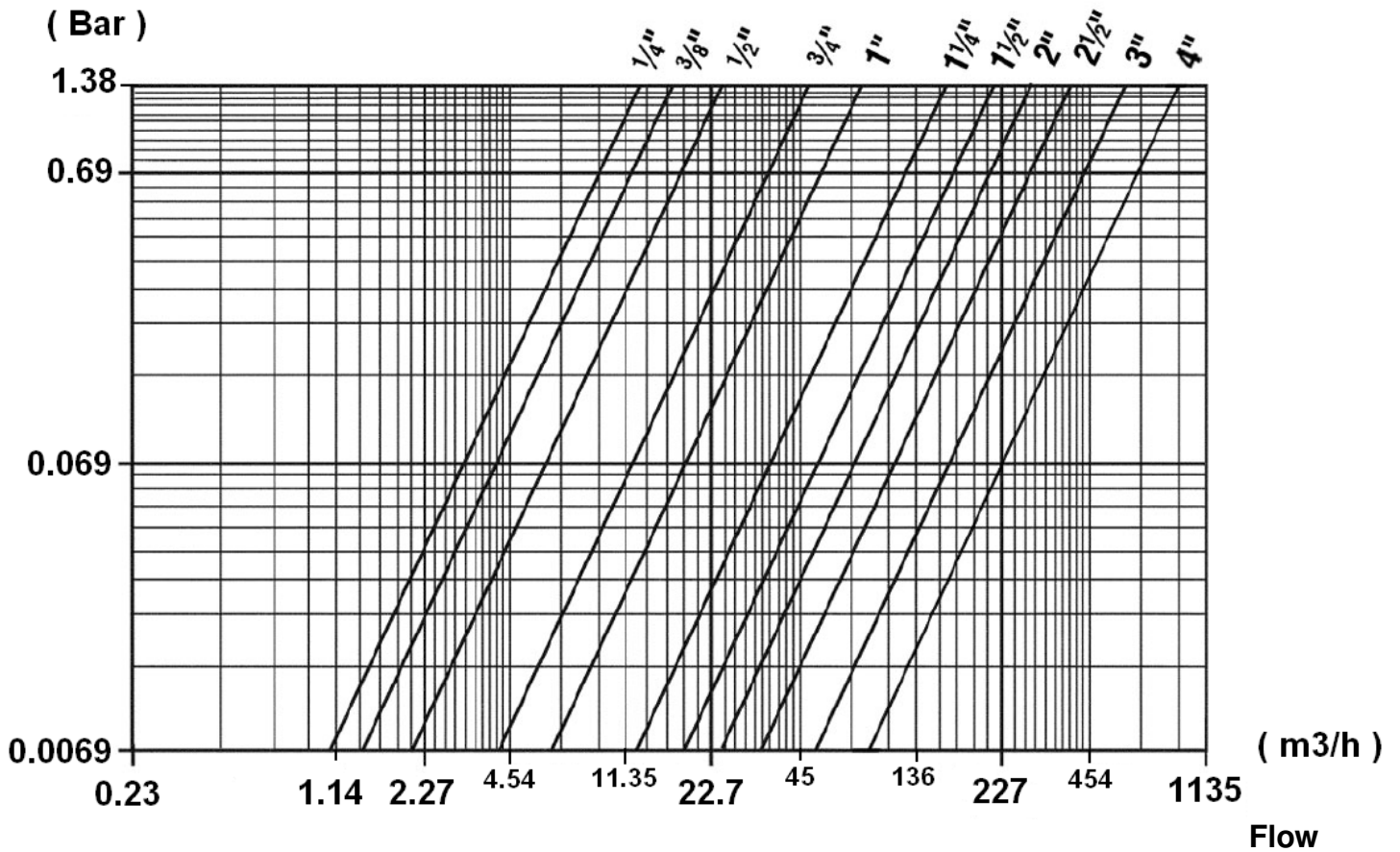

BRONZE GATE VALVE PN10/16
RANGE :

- Bronze female/female threaded BSP cylindric **Ref. 146** DN 1/4" to DN 4"

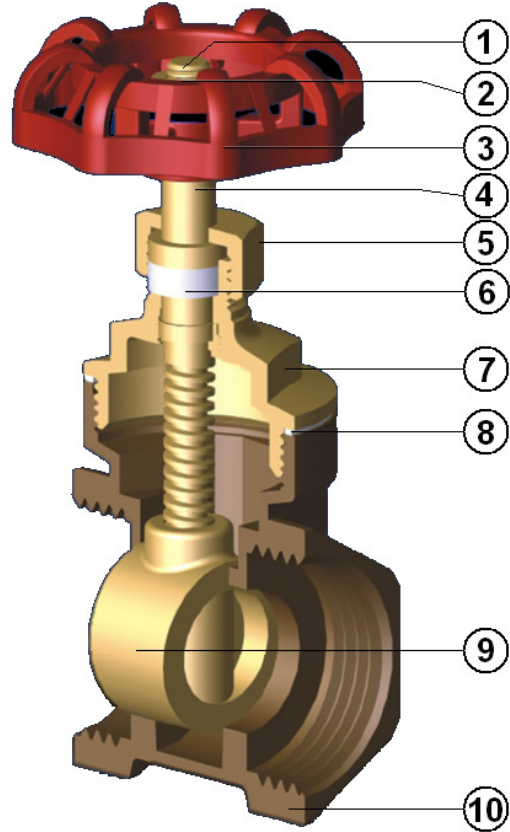
MATERIALS :

Item	Designation	Materials
1	Handwheel nut	Brass
2	ID plate	Aluminium
3	Handwheel DN 1/4" to 1"1/2	Aluminium
3	Handwheel DN 2" to 4"	Cast iron
4	Stem	Brass
5	Packing nut	Brass
6	Packing	PTFE
7	Bonnet	Brass
8	Bonnet gasket (DN1/4" to 2")	PTFE
9	Wedge disc	Brass
10	Body	Bronze

BRONZE GATE VALVE PN10/16

SIZE (in mm) :

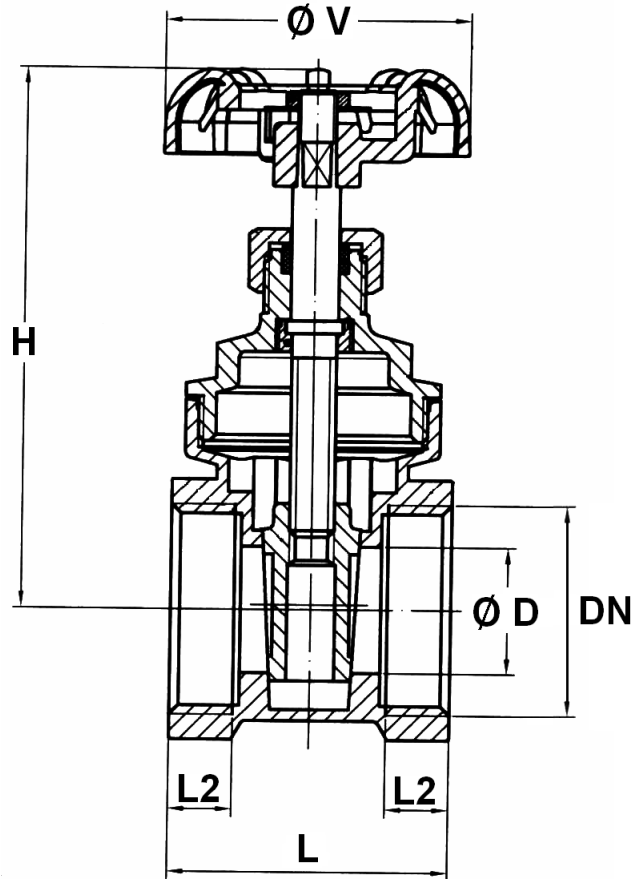

DN	1/4"	3/8"	1/2"	3/4"	1"	1"1/4	1"1/2	2"	2"1/2	3"	4"
Ø D	11.6	12.5	14	17	20	25	31	43	60	70	84
L	33	36	37	40	44	50	52	56	65	70	83
L2	9	9	9	9.5	10	11.5	12	13	13.5	14	17
H	58	58	62	69	75	90	98	118	157	177	211
Ø V	48	48	48	55	55	70	80	78	98	105	127
Weight (Kg)	0.17	0.16	0.18	0.25	0.33	0.51	0.67	0.97	2.01	2.54	4.80

BRONZE GATE VALVE PN10/16

STANDARDS :

- Fabrication according to ISO 9001 :2000
- DIRECTIVE 97/23/CE : Concerned by article 3, § 3
- Threaded female / female BSP cylindric according to ISO 228/1

ADVICE : Our opinion and our advice are not guaranteed and SFERACO shall not be liable for the consequences of damages.
The customer must check the right choice of the products with the real service conditions.

BRONZE GATE VALVE PN10/16

INSTALLATION INSTRUCTIONS

GENERAL GUIDELINES :

- Ensure that the valves to be used are appropriate for the conditions of the installation (type of fluid, pressure and temperature).
- Be sure to have enough valves to be able to isolate the sections of piping as well as the appropriate equipment for maintenance and repair.
- Ensure that the valves to be installed are of correct strength to be able to support the capacity of their usage.
- **Installation of all circuits should ensure that their function can be automatically tested on a regular basis (at least two times a year).**

INSTALLATION INSTRUCTIONS :

- **Before installing the valves, clean and remove any objects from the pipes** (in particular bits of sealing and metal) which could obstruct and block the valves.
- **Ensure that both connecting pipes either side of the valve (upstream and downstream) are aligned (if they're not, the valves may not work correctly).**
- **Make sure that the two sections of the pipe (upstream and downstream) match, the valve unit will not absorb any gaps. Any distortions in the pipes may affect the tightness of the connection, the working of the valve and can even cause a rupture.** To be sure, place the kit in position to ensure the assembling will work.
- **If sections of piping do not have their final support in place, they should be temporarily fixed. This is to avoid unnecessary strain on the valve.**
- It's recommended to operate the valve (open and close) 1 to 2 times per year