

STAINLESS STEEL GATE VALVE PN16



**Lloyd's
Register**

PED 97/23/CE



Size : DN 1/2" to 2"
Ends : Female - Female BSP
Min Temperature : - 20°C
Max Temperature : + 180°C
Max Pressure : 16 Bars
Specifications : Rotating non rising stem
Inside screw stem
Full bore

Materials : Stainless steel

STAINLESS STEEL GATE VALVE PN16

SPECIFICATIONS :

- Full bore
- Rotating non rising stem
- Inside screw stem
- Screwed bonnet
- Single wedge
- Female / Female BSP cylindrical
- PTFE packing

USE :

- For all common fluids
- Min and max Temperature Ts : - 20°C to + 180°C
- Max Pressure PN : 16 bars

HEAD LOSS GRAPH :

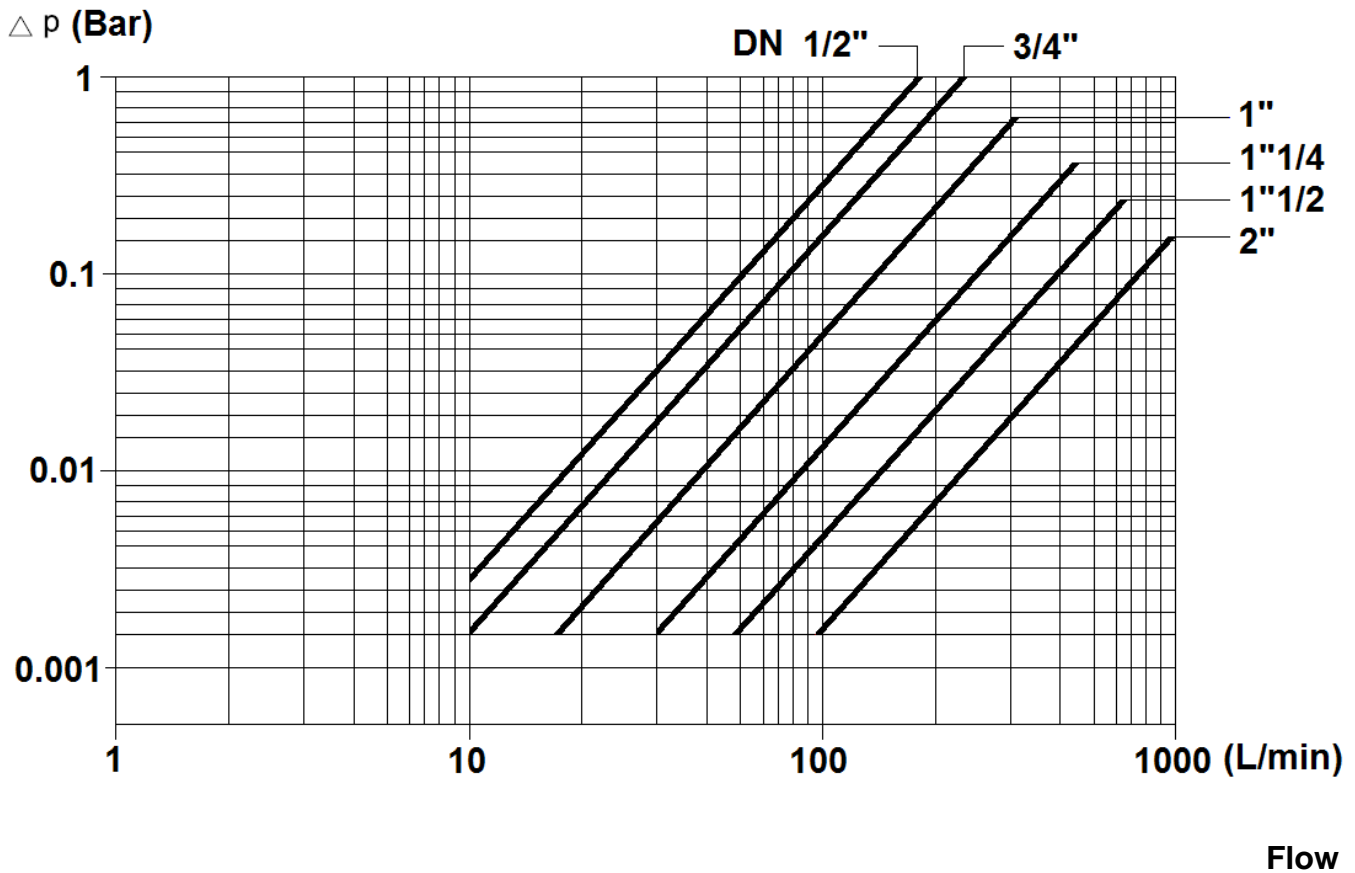

STAINLESS STEEL GATE VALVE PN16

FLOW COEFFICIENT Kv (M3 / h) :

DN	1/2"	3/4"	1"	1"1/4	1"1/2	2"
Kv (m3/h)	19.18	35.43	57.72	96.69	154.63	254

PRESSURE / TEMPERATURE GRAPH (STEAM EXCLUDED):

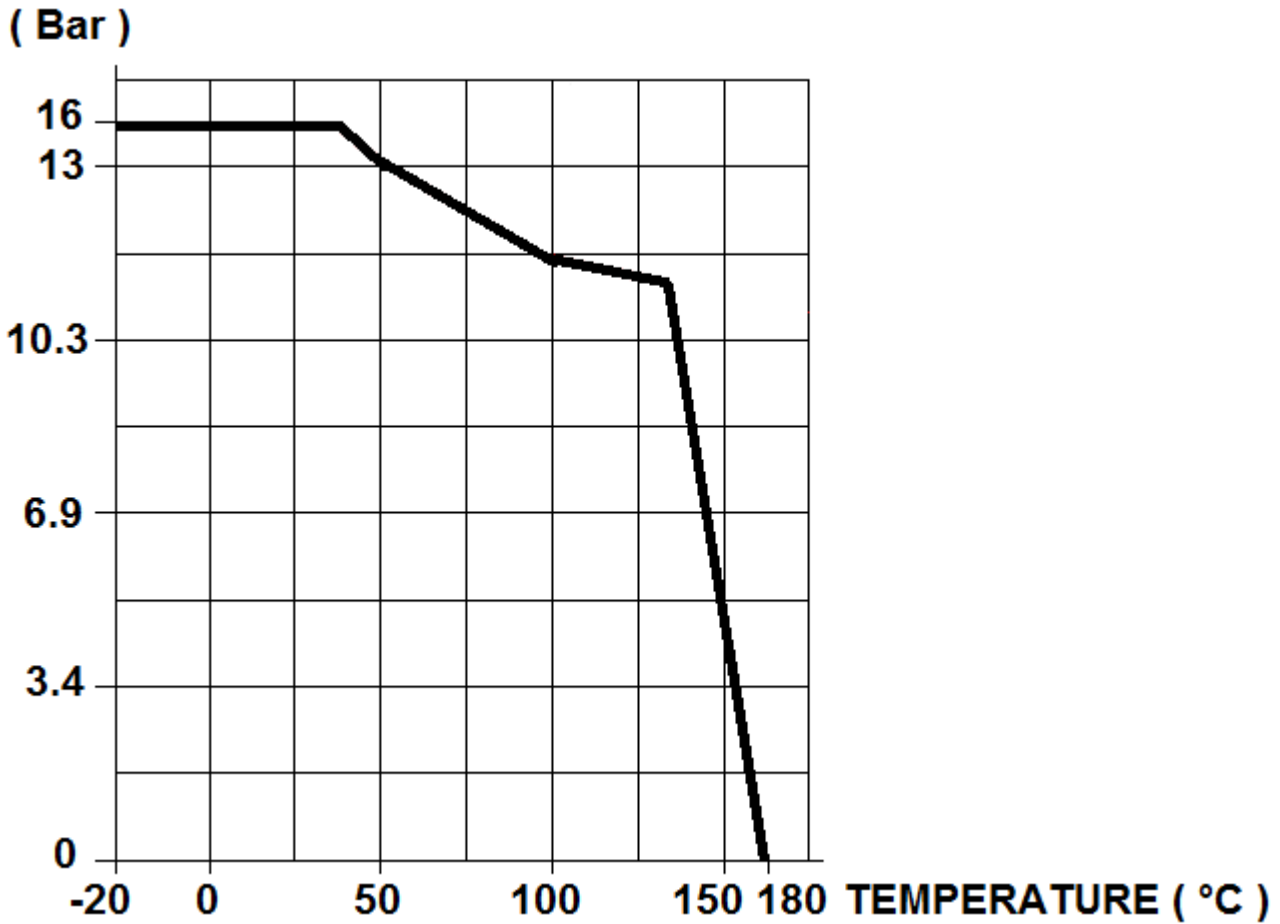

RANGE :

- Female / female threaded BSP cylindrical **Ref. 106** from DN 1/2" to DN 2"

STAINLESS STEEL GATE VALVE PN16

MATERIALS :

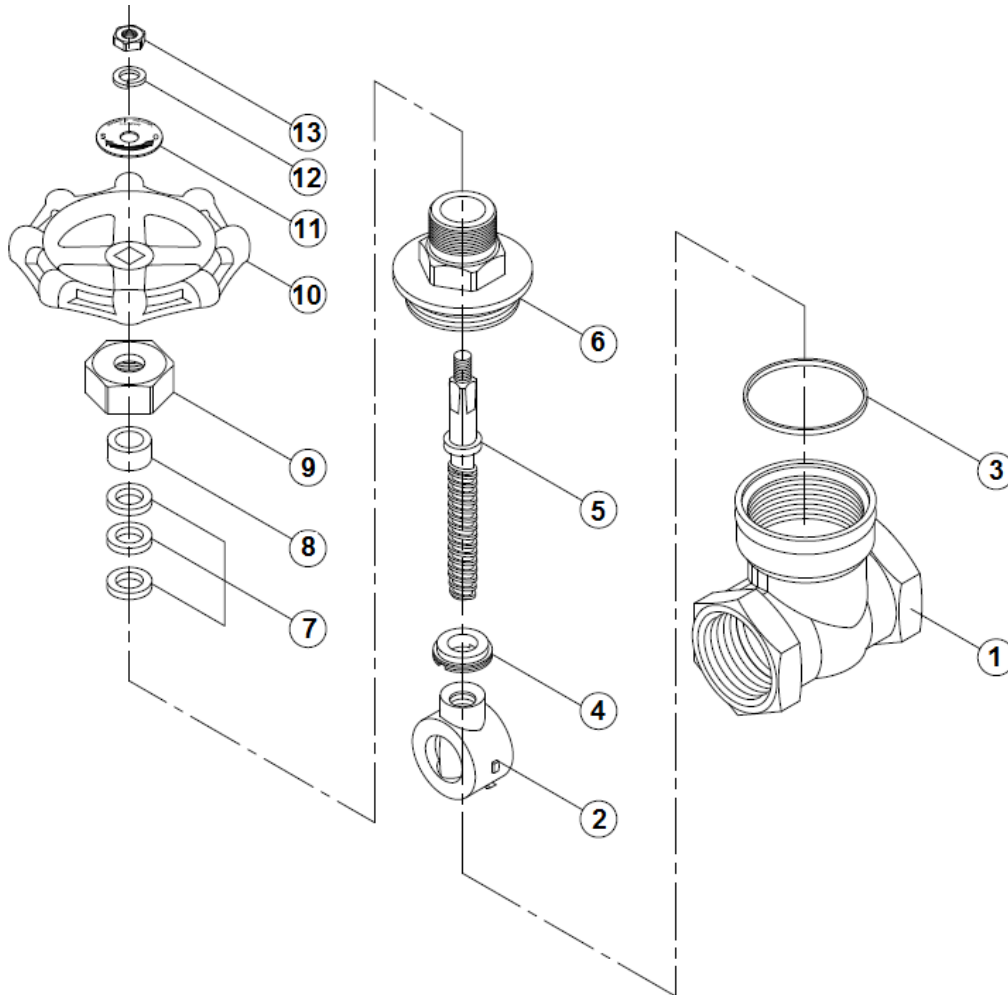

Item	Designation	Materials
1	Body	ASTM A351 CF8M
2	Wedge	ASTM A351 CF8M
3	Body gasket	PTFE
4	Nut	SS 304
5	Stem	SS 316
6	Bonnet	ASTM A351 CF8M
7	Packing	PTFE
8	Gland follower	SS 304
9	Packing nut	SS 316
10	Handwheel	Zamak
11	ID plate	Aluminium
12	Handwheel washer	SS 304
13	Handwheel nut	SS 304

STAINLESS STEEL GATE VALVE PN16

SIZE (in mm) :

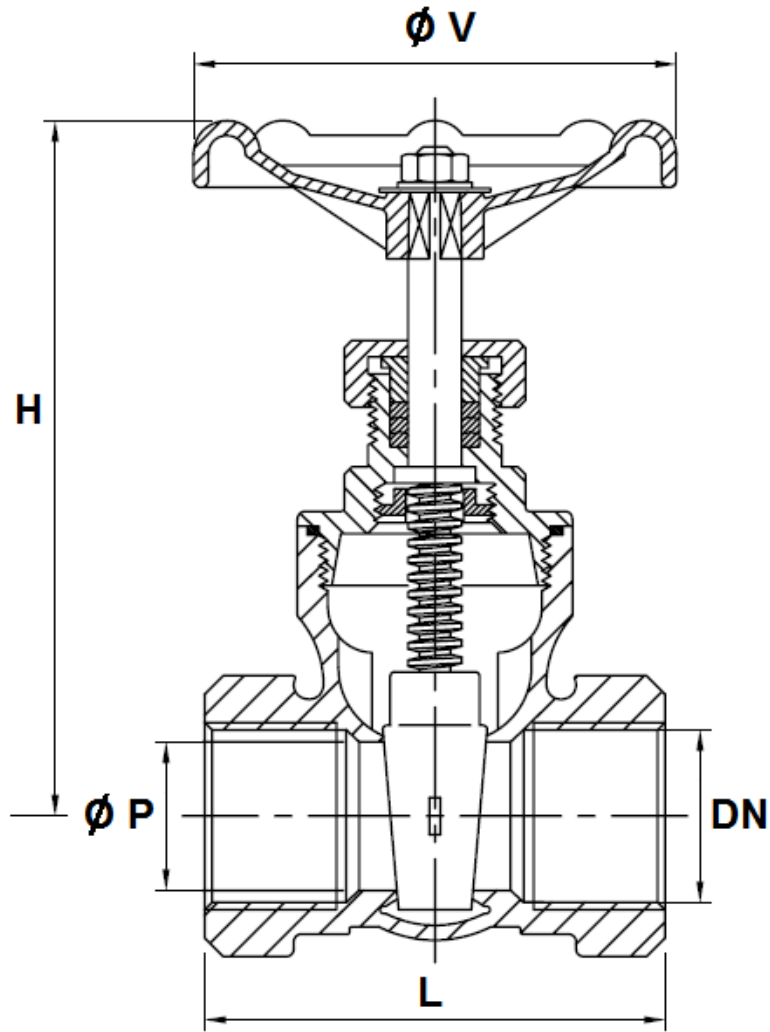

Ref.	DN	1/2"	3/4"	1"	1"1/4	1"1/2	2"
106	Ø P	15	20	25	32	40	50
	L	55	60.5	65.5	76.5	85.5	95.5
	H	92	97	108.5	123.5	146	162
	Ø V	70	70	80	80	90	100
	Weight (Kg)	0.440	0.570	0.740	1.120	1.550	2.250

STAINLESS STEEL GATE VALVE PN16

STANDARDS :

- Fabrication according to ISO 9001 :2008
- DIRECTIVE 97/23/CE : CE n° 0038 Module H
Risk category I up to DN 1"1/4
Risk category II from DN 1"1/2 to DN 2"
- Threaded female / female BSP cylindrical according to ISO 228/1

ADVICE : Our opinion and our advice are not guaranteed and SFERACO shall not be liable for the consequences of damages.
The customer must check the right choice of the products with the real service conditions.

STAINLESS STEEL GATE VALVE PN16

INSTALLATION INSTRUCTIONS

GENERAL GUIDELINES :

- Ensure that the valves to be used are appropriate for the conditions of the installation (type of fluid, pressure and temperature).
- Be sure to have enough valves to be able to isolate the sections of piping as well as the appropriate equipment for maintenance and repair.
- Ensure that the valves to be installed are of correct strength to be able to support the capacity of their usage.
- **Installation of all circuits should ensure that their function can be automatically tested on a regular basis (at least two times a year).**

INSTALLATION INSTRUCTIONS :

- **Before installing the valves, clean and remove any objects from the pipes** (in particular bits of sealing and metal) which could obstruct and block the valves.
- **Ensure that both connecting pipes either side of the valve (upstream and downstream) are aligned (if they're not, the valves may not work correctly).**
- **Make sure that the two sections of the pipe (upstream and downstream) match, the valve unit will not absorb any gaps. Any distortions in the pipes may affect the tightness of the connection, the working of the valve and can even cause a rupture.** To be sure, place the kit in position to ensure the assembling will work.
- The theoretical lengths given by ISO/R7 for the tapping are typically longer than required, the length of the thread should be limited, and **check that the end of the tube does not press right up to the head of the thread.**
- **Never use a vice to tighten the fixings of the valve.**
- **If sections of piping do not have their final support in place, they should be temporarily fixed. This is to avoid unnecessary strain on the valve.**
- **It may be necessary to screw the packing gland during using according to the type of use.**
- **Do not use a tool to shut the valve**
- **Fluids in the valve must not contain solid objects (it could damaged the seat).**
- It's recommended to operate the valve (open and close) 1 to 2 times per year