

ANSI/ASME Cast Steel Globe Valves



Flanged Bonnet

Flanged Ends

Class 150-600
2"-12"

Application

- Refineries, power stations, process and general industry
- For water, steam, gas, oil, and other media
- Other applications on request

Operating Data

- Maximum allowable pressure 1500 psi (106 bar)
- Maximum allowable temperature 1500 °F (816 °C)
- Pressure/Temperature ratings per ASME B16.34
- Temperature below 0°C on request

Materials

- ASTM A216 WCB up to 800 °F (427 °C)
- ASTM A217 WC6 up to 1100 °F (593 °C)
- ASTM A217 WC9 up to 1100 °F (593 °C)
- ASTM A217 C5 up to 1200 °F (649 °C)
- ASTM A217 C12 up to 1200 °F (649 °C)
- ASTM A352 LCB up to 650 °F (343 °C)
- ASTM A352 LCC up to 650 °F (343 °C)
- ASTM A351 CF8 up to 1500 °F (816 °C)
- ASTM A351 CF8M up to 1500 °F (816 °C)

Trim Materials

- Trim 1 13Cr/13Cr
- Trim 2 304/304
- Trim 5 Stellite/Stellite
- Trim 8 Stellite/13Cr
- Trim 10 316/316

Design

- Globe valve design per BS 1873
- Pressure/temperature rating per ASME B16.34
- End-end dimension per ASME B16.10
- Flange dimensions per ASME B16.5
- Testing per API 598
- Bolted bonnet
- Outside screw and yoke
- Graphite packing
- Stainless steel/graphite gaskets

The valves meet the safety requirements of the Pressure Equipment Directive 97/23/EC (PED) of annex I for fluids of the groups 1 and 2.

Variants on request

- Gear operators
- Electric actuators
- Bypass execution
- Radiography
- Buttweld ends per ASME B16.25
- Throttling Cone
- Other variants

Remarks

- EcoLine gate valve type series booklet no. 7247.11
- EcoLine check valve type series booklet no. 7247.13
- Operating instructions no: 7427.8000.831

On all enquiries / orders please specify

1. Valve Type
2. ANSI Pressure Class
3. Size
4. Design pressure
5. Design temperature
6. Differential Pressure-shut off
7. Flow Medium
8. Material of Construction
9. Trim Material (API Trim Number)
10. Type of End Connection
11. Pipe Schedule (for Buttweld Ends)
12. Variants
13. Type Series Booklet Number
14. Valve Data Sheet if Applicable

When ordering spare parts, indicate valve product code (shown on nameplate) and serial number.



Pressure/Temperature ratings (ASME B16.34 Standard Class)

ASTM A216 WCB

Temperature		Class 150		Class 300		Class 600	
°F	°C	psi	bar	psi	bar	psi	bar
32 to 100	0 to 38	285	19.7	740	51.0	1480	102.0
200	93	260	17.9	675	46.5	1350	93.1
300	149	230	15.9	655	45.2	1315	90.7
400	204	200	13.8	635	43.8	1270	87.6
500	260	170	11.7	600	41.4	1200	82.7
600	316	140	9.7	550	37.9	1095	75.5
650	343	125	8.6	535	36.9	1075	74.1
700	371	110	7.6	535	36.9	1065	73.4
750	399	95	6.6	505	34.8	1010	69.6
800	427	80	5.5	410	28.3	825	56.9
850 (1)	454	65	4.5	270	18.6	535	36.9
900 (1)	482	50	3.4	170	11.7	345	23.8
950 (1)	510	35	2.4	105	7.2	205	14.1
1000 (1)	538	20	1.4	50	3.4	105	7.2

Note 1. Permissible but not recommended for prolonged usage Above 800 °F (427 °C).

ASTM A217 WC6

Temperature		Class 150		Class 300		Class 600	
°F	°C	psi	bar	psi	bar	psi	bar
32 to 100	0 to 38	290	20.0	750	51.7	1500	103.4
200	93	260	17.9	750	51.7	1500	103.4
300	149	230	15.9	720	49.6	1445	99.6
400	204	200	13.8	695	47.9	1385	95.5
500	260	170	11.7	665	45.9	1330	91.7
600	316	140	9.7	605	41.7	1210	83.4
650	343	125	8.6	590	40.7	1175	81.0
700	371	110	7.6	570	39.3	1135	78.3
750	399	95	6.6	530	36.5	1065	73.4
800	427	80	5.5	510	35.2	1015	70.0
850	454	65	4.5	485	33.4	975	67.2
900	482	50	3.4	450	31.0	900	62.1
950	510	35	2.4	320	22.1	640	44.1
1000	538	20	1.4	215	14.8	430	29.6
1050	566	20 (1)	1.4 (1)	145	10.0	290	20.0
1100	593	20 (1)	1.4 (1)	95	6.6	190	13.1

Note 1. For welded end valves only. Flanged end ratings terminate at 1000 °F (593 °C).

Note 2. Not to be used over 1100 °F (593 °C).

ASTM A217 C5

Temperature		Class 150		Class 300		Class 600	
°F	°C	psi	bar	psi	bar	psi	bar
32 to 100	0 to 38	290	20.0	750	51.7	1500	103.4
200	93	260	17.9	745	51.4	1490	102.7
300	149	230	15.9	715	49.3	1430	98.6
400	204	200	13.8	705	48.6	1410	97.2
500	260	170	11.7	665	45.9	1330	91.7
600	316	140	9.7	605	41.7	1210	83.4
650	343	125	8.6	590	40.7	1175	81.0
700	371	110	7.6	570	39.3	1135	78.3
750	399	95	6.6	530	36.5	1055	72.7
800	427	80	5.5	510	35.2	1015	70.0
850	454	65	4.5	485	33.4	965	66.5
900	482	50	3.4	370	25.5	740	51.0
950	510	35	2.4	275	19.0	550	37.9
1000	538	20	1.4	200	13.8	400	27.6
1050	566	20 (1)	1.4 (1)	145	10.0	290	20.0
1100	593	20 (1)	1.4 (1)	100	6.9	200	13.8
1150	621	20 (1)	1.4 (1)	60	4.1	125	8.6
1200	649	15 (1)	1.0 (1)	35	2.4	70	4.8

Note 1. For welded end valves only. Flanged end ratings terminate at 1000 °F (593 °C).

ASTM A217 WC9

Temperature		Class 150		Class 300		Class 600	
°F	°C	psi	bar	psi	bar	psi	Bar
32 to 100	0 to 38	290	20.0	750	51.7	1500	103.4
200	93	260	17.9	750	51.7	1500	103.4
300	149	230	15.9	730	50.3	1455	100.3
400	204	200	13.8	705	48.6	1410	97.2
500	260	170	11.7	665	45.9	1330	91.7
600	316	140	9.7	605	41.7	1210	83.4
650	343	125	8.6	590	40.7	1175	81.0
700	371	110	7.6	570	39.3	1135	78.3
750	399	95	6.6	530	36.5	1065	73.4
800	427	80	5.5	510	35.2	1015	70.0
850	454	65	4.5	485	33.4	975	67.2
900	482	50	3.4	450	31.0	900	62.1
950	510	35	2.4	375	25.9	755	52.1
1000	538	20	1.4	260	17.9	520	35.9
1050	566	20 (1)	1.4 (1)	175	12.1	350	24.1
1100	593	20 (1)	1.4 (1)	110	7.6	220	15.2

ASTM A217 C12

Temperature		Class 150		Class 300		Class 600	
°F	°C	psi	bar	psi	bar	psi	Bar
32 to 100	0 to 38	290	20.0	750	51.7	1500	103.4
200	93	260	17.9	750	51.7	1500	103.4
300	149	230	15.9	730	50.3	1455	100.3
400	204	200	13.8	705	48.6	1410	97.2
500	260	170	11.7	665	45.9	1330	91.7
600	316	140	9.7	605	41.7	1210	83.4
650	343	125	8.6	590	40.7	1175	81.0
700	371	110	7.6	570	39.3	1135	78.3
750	399	95	6.6	530	36.5	1065	73.4
800	427	80	5.5	510	35.2	1015	70.0
850	454	65	4.5	485	33.4	975	67.2
900	482	50	3.4	450	31.0	900	62.1
950	510	35	2.4	375	25.9	755	52.1
1000	538	20	1.4	255	17.6	505	34.8
1050	566	20 (1)	1.4 (1)	170	11.7	345	23.8
1100	593	20 (1)	1.4 (1)	115	7.9	225	15.5
1150	621	20 (1)	1.4 (1)	75	5.2	150	10.3
1200	649	20 (1)	1.4 (1)	50	3.4	105	7.2

ASTM A352 LCB

Temperature		Class 150		Class 300		Class 600	
°F	°C	psi	bar	psi	bar	psi	bar
32 to 100	0 to 38	265	18.3	695	47.9	1390	95.8
200	93	250	17.2	655	45.2	1315	90.7
300	149	230	15.9	640	44.1	1275	87.9
400	204	200	13.8	620	42.7	1235	85.2
500	260	170	11.7	585	40.3	1165	80.3
600	316	140	9.7	535	36.9	1065	73.4
650	343	125	8.6	525	36.2	1045	72.1

Note 1. Not to be used above 650 °F (343 °C).

ASTM A352 LCC

Temperature		Class 150		Class 300		Class 600	
°F	°C	psi	bar	psi	bar	psi	Bar
32 to 100	0 to 38	290	20.0	750	51.7	1500	103.4
200	93	260	17.9	750	51.7	1500	103.4
300	149	230	15.9	730	50.3	1465	101.0
400	204	200	13.8	705	48.6	1410	97.2
500	260	170	11.7	665	45.9	1330	91.7
600	316	140	9.7	605	41.7	1210	83.4
650	343	125	8.6	590	40.7	1175	81.0

ASTM A351 CF8

Temperature		Class 150		Class 300		Class 600	
°F	°C	psi	bar	psi	bar	psi	bar
32 to 100	0 to 38	275	19.0	720	49.6	1440	99.3
200	93	230	15.9	600	41.4	1200	82.7
300	149	205	14.1	540	37.2	1080	74.5
400	204	190	13.1	495	34.1	995	68.6
500	260	170	11.7	465	32.1	930	64.1
600	316	140	9.7	435	30.0	875	60.3
650	343	125	8.6	430	29.6	860	59.3
700	371	110	7.6	425	29.3	850	58.6
750	399	95	6.6	415	28.6	830	57.2
800	427	80	5.5	405	27.9	805	55.5
850	454	65	4.5	395	27.2	790	54.5
900	482	50	3.4	390	26.9	780	53.8
950	510	35	2.4	380	26.2	765	52.7
1000(2)	538	20	1.4	320	22.1	640	44.1
1050(2)	566	20 (1)	1.4 (1)	310	21.4	615	42.4
1100(2)	593	20 (1)	1.4 (1)	255	17.6	515	35.5
1150(2)	621	20 (1)	1.4 (1)	200	13.8	400	27.6
1200(2)	649	20 (1)	1.4 (1)	155	10.7	310	21.4
1250(2)	677	20 (1)	1.4 (1)	115	7.9	225	15.5
1300(2)	704	20 (1)	1.4 (1)	85	5.9	170	11.7
1350(2)	732	20 (1)	1.4 (1)	60	4.1	125	8.6
1400(2)	760	20 (1)	1.4 (1)	50	3.4	95	6.6
1450(2)	788	15 (1)	1.0 (1)	35	2.4	70	4.8
1500(2)	816	10 (1)	0.7 (1)	25	1.7	44	3.0

Note 1. For welded end valves only. Flanged end ratings terminate at 1000 °F (593 °C).

Note 2. At temperatures over 1000 °F (593 °C), use only when carbon content is 0.04% or higher.

ASTM A351 CF8M

Temperature		Class 150		Class 300		Class 600	
°F	°C	psi	bar	psi	bar	psi	Bar
32 to 100	0 to 38	275	19.0	720	49.6	1440	99.3
200	93	235	16.2	620	42.7	1240	85.5
300	149	215	14.8	560	38.6	1120	77.2
400	204	195	13.4	515	35.5	1025	70.7
500	260	170	11.7	480	33.1	955	65.8
600	316	140	9.7	450	31.0	900	62.1
650	343	125	8.6	445	30.7	890	61.4
700	371	110	7.6	430	29.6	870	60.0
750	399	95	6.6	425	29.3	855	59.0
800	427	80	5.5	420	29.0	845	58.3
850	454	65	4.5	420	29.0	835	57.6
900	482	50	3.4	415	28.6	830	57.2
950	510	35	2.4	385	26.5	775	53.4
1000	538	20	1.4	350	24.1	700	48.3
1050(2)	566	20 (1)	1.4 (1)	345	23.8	685	47.2
1100(2)	593	20 (1)	1.4 (1)	305	21.0	610	42.1
1150(2)	621	20 (1)	1.4 (1)	235	16.2	475	32.8
1200(2)	649	20 (1)	1.4 (1)	185	12.8	370	25.5
1250(2)	677	20 (1)	1.4 (1)	145	10.0	295	20.3
1300(2)	704	20 (1)	1.4 (1)	115	7.9	235	16.2
1350(2)	732	20 (1)	1.4 (1)	95	6.6	190	13.1
1400(2)	760	20 (1)	1.4 (1)	75	5.2	150	10.3
1450(2)	788	20 (1)	1.4 (1)	60	4.1	115	7.9
1500(2)	816	20 (1)	1.4 (1)	40	2.8	85	5.9

Globe Valves - Type GL
Design Specifications

General Valve Design	: BS 1873
Pressure/Temperature Rating	: ASME B16.34
Flange Dimensions	: ASME B16.5
Buttweld Ends	: ASME B16.25
End-to-End	: ASME B16.10
Testing	: API 598

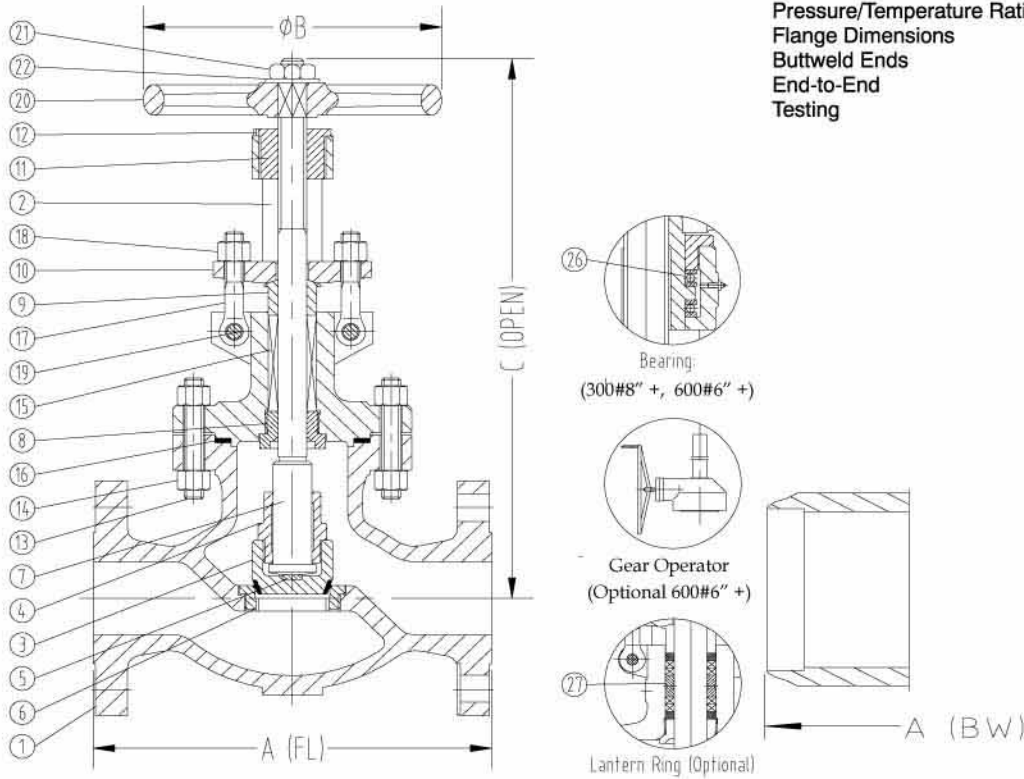
Dimensions

CLASS 150		2	2.5	3	4	6	8	10	12
A (FL)	inch	8.00	8.50	9.50	11.50	16.00	19.50	24.50	27.50
	mm	203	216	241	292	406	495	622	698
A (BW)	inch	8.00	8.50	9.50	11.50	16.00	19.50	24.50	27.50
	mm	203	216	241	292	406	495	622	698
B	inch	8	8	10	14	14	18	20	25
	mm	200	200	250	350	350	450	500	640
C	inch	13.3	16.3	16.0	18.4	22.0	26.5	33.8	33.9
	mm	338	415	406	468	560	672	858	862
Wt.	lbs	42	70	77	121	254	309	562	1186
	kg	19	32	35	55	115	140	255	539

CLASS 300		2	2.5	3	4	6	8	10	12
A (FL)	inch	10.50	11.50	12.50	14.00	17.50	22.00	24.50	28.00
	mm	267	292	318	356	444	559	622	711
A (BW)	inch	10.50	11.50	12.50	14.00	17.50	22.00	24.50	28.00
	mm	267	292	318	356	444	559	622	711
B	inch	8	10	10	14	18	20	20	26
	mm	200	250	250	350	450	500	500	650
C	inch	14.0	18.7	16.9	19.7	23.9	32.6	36.0	40.6
	mm	355	474	430	500	607	828	914	1032
Wt.	lbs	60	106	106	154	276	639	805	1390
	kg	27	48	48	70	125	290	365	632

CLASS 600		2	2.5	3	4	6	8	10	12
A (FL)	inch	11.50	13.00	14.00	17.00	22.00	26.00	31.00	33.00
	mm	292	330	356	432	559	660	787	838
A (BW)	inch	11.50	13.00	14.00	17.00	22.00	26.00	31.00	33.00
	mm	292	330	356	432	559	660	787	838
B	inch	10	10	12	14	20	24	24	24
	mm	250	250	350	350	500	610	610	610
C	inch	11.8	21.3	19.2	21.9	30.6	36.0	43.8	50.4
	mm	300	540	488	555	777	915	1113	1280
Wt.	lbs	77	154	143	231	474	1168	1720	1980
	kg	35	70	65	105	215	530	780	900

Materials

Part No.	Part Name	WCB	WC6	WC9	C5	C12	LCB	LCC	CF8	CF8M	
1	Body	A216 WCB	A217 WC6	A217 WC9	A217 C5	A217 C12	A352 LCB	A352 LCC	A351 CF8	A351 CF8M	
2	Bonnet	A216 WCB	A217 WC6	A217 WC9	A217 C5	A217 C12	A352 LCB	A352 LCC	A351 CF8	A351 CF8M	
3	Disc Base	A216 WCB	A217 WC6	A217 WC9	A217 C5	A217 C12	A352 LCB	A352 LCC	A351 CF8	A351 CF8M	
4	Disc Nut	13Cr	13Cr	13Cr	13Cr	13Cr	304	304	304	316	
5	Thrust Washer	13Cr	13Cr	13Cr	13Cr	13Cr	304	304	304	316	
6	Seat Ring Base	A105	A182 F11	A182 F22	A182 F5	A182 F9	A350 LF2	A350 LF2	Integral		
7	Stem	See Trim Material Table									
8	Backseat Bushing	See Trim Material Table									
9	Gland	13Cr	13Cr	13Cr	13Cr	13Cr	304	304	304	316	
10	Gland Flange	A216 WCB	A217 WC6	A217 WC9	A217 C5	A217 C12	A352 LCB	A352 LCC	A351 CF8	A351 CF8M	
11	Yoke Bushing	A439 D2C									
12	Set Screw	Carbon Steel							Stainless Steel		
13	Bonnet Studs	A193 B7	A193 B16	A193 B16	A193 B16	A193 B16	A320 L7	A320 L7	A193 B8	A193 B8	
14	Bonnet Nuts	A194 2H	A194 Gr. 4	A194 Gr. 4	A194 Gr. 4	A194 Gr. 4	A194 Gr. 4	A194 Gr. 4	A194 Gr. 8	A194 Gr. 8	
15	Packing	Graphite									
16	Gasket	Graphite + Stainless Steel									
17	Eyebolt	A307 B	A193 B16	A193 B16	A193 B16	A193 B16	A320 L7	A320 L7	A193 B8	A193 B8	
18	Eyebolt Nuts	A194 2H	A194 Gr. 4	A194 Gr. 4	A194 Gr. 4	A194 Gr. 4	A194 Gr. 4	A194 Gr. 4	A194 Gr. 8	A194 Gr. 8	
19	Eyebolt Pins	Carbon Steel							Stainless Steel		
20	Handwheel	Ductile or Malleable Iron									
21	Handwheel Nut	Carbon Steel							Stainless Steel		
22	Washer	Carbon Steel							Stainless Steel		
23	Yoke	A216 WCB	A217 WC6	A217 WC9	A217 C5	A217 C12	A352 LCB	A352 LCC	A351 CF8	A351 CF8M	
24	Yoke Bolts	A193 B7	A193 B16	A193 B16	A193 B16	A193 B16	A320 L7	A320 L7	A193 B8	A193 B8	
25	Yoke Nuts	A194 2H	A194 Gr. 4	A194 Gr. 4	A194 Gr. 4	A194 Gr. 4	A194 Gr. 4	A194 Gr. 4	A194 Gr. 8	A194 Gr. 8	
26	Bearing	Steel									
27	Lantern Ring	13Cr	13Cr	13Cr	13Cr	13Cr	304	304	304	316	

Trim Materials

Part No.	Part Name	Trim 1 13Cr/13Cr	Trim 2 304/304	Trim 5 Stellite/Stellite	Trim 8 Stellite/13Cr	Trim 10 316/316
3	Disc Face	13Cr	304 Stainless Steel	Stellite	13Cr	316 Stainless Steel
6	Seat Ring Face	13Cr	304 Stainless Steel	Stellite	Stellite	316 Stainless Steel
7	Stem	13Cr	304 Stainless Steel	13Cr	13Cr	316 Stainless Steel
8	Backseat Bushing	13Cr	304 Stainless Steel	13Cr	13Cr	316 Stainless Steel

Test Requirements

Test	Medium	Class 150		Class 300		Class 600	
		psi	bar	psi	bar	psi	bar
Shell	Water	450	32	1125	78	2225	153
Backseat	Water	315	23	815	56	1630	112
Seat	Water	315	23	815	56	1630	112

Note: A216 WCB test pressures

Flange Dimensions (ASME B16.5)

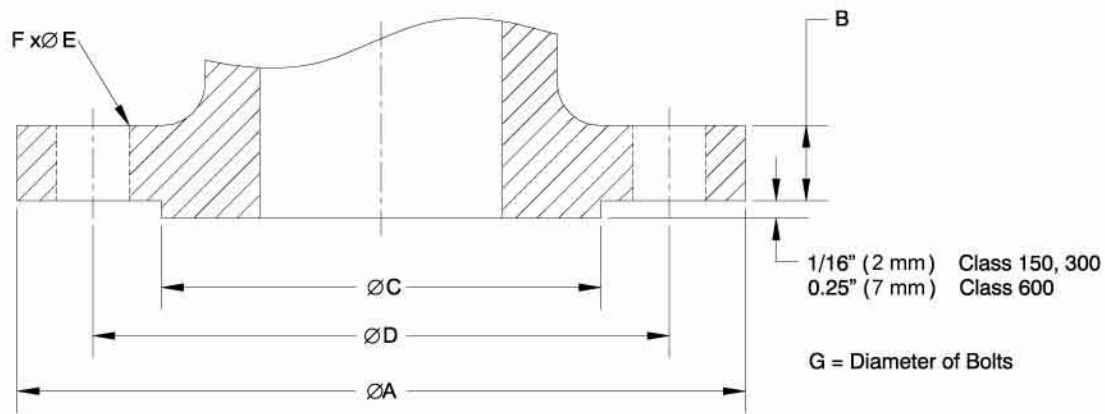

Class 150

Inches							
Size	A	B	C	D	E	F	G
2	6.00	0.56	3.62	4.75	0.75	4	$5/8$
2.5	7.00	0.62	4.12	5.50	0.75	4	$5/8$
3	7.50	0.69	5.00	6.00	0.75	4	$5/8$
4	9.00	0.88	6.19	7.50	0.75	8	$5/8$
6	11.00	0.94	8.50	9.50	0.88	8	$3/4$
8	13.50	1.06	10.62	11.75	0.88	8	$3/4$
10	16.00	1.12	12.75	14.25	1.00	12	$7/8$
12	19.00	1.19	15.00	17.00	1.00	12	$7/8$

Millimeters							
DN	A	B	C	D	E	F	G
50	150	14.3	92.1	120.7	19.1	4	15.9
65	180	15.9	104.8	139.7	19.1	4	15.9
80	190	17.5	127.0	152.4	19.1	4	15.9
100	230	22.3	157.2	190.5	19.1	8	15.9
150	280	23.9	215.9	241.3	22.4	8	19.1
200	345	27.0	269.9	298.5	22.4	8	19.1
250	405	28.6	323.8	362.0	25.4	12	22.2
300	485	30.2	381.0	431.8	25.4	12	22.2

Class 300

Inches							
Size	A	B	C	D	E	F	G
2	6.50	0.81	3.62	5.00	0.75	8	$5/8$
2.5	7.50	0.94	4.12	5.88	0.88	8	$3/4$
3	8.25	1.06	5.00	6.62	0.88	8	$3/4$
4	10.00	1.19	6.19	7.88	0.88	8	$3/4$
6	12.50	1.38	8.50	10.62	0.88	12	$3/4$
8	15.00	1.56	10.62	13.00	1.00	12	$7/8$
10	17.50	1.81	12.75	15.25	1.12	16	1
12	20.50	1.94	15.00	17.75	1.25	16	$1-1/8$

Millimeters							
DN	A	B	C	D	E	F	G
50	165	20.7	92.1	127.0	19.1	8	15.9
65	190	23.9	104.8	149.2	22.4	8	19.1
80	210	27.0	127.0	168.3	22.4	8	19.1
100	255	30.2	157.2	200.0	22.4	8	19.1
150	320	35.0	215.9	269.9	22.4	12	19.1
200	380	39.7	269.9	330.2	25.4	12	22.2
250	445	46.1	323.8	387.4	28.4	16	25.4
300	520	49.3	381.0	450.8	31.8	16	28.6

Class 600

Inches							
Size	A	B	C	D	E	F	G
2	6.50	1.00	3.62	5.00	0.75	8	$5/8$
2.5	7.50	1.12	4.12	5.88	0.88	8	$3/4$
3	8.25	1.25	5.00	6.62	0.88	8	$3/4$
4	10.75	1.50	6.19	8.50	1.00	8	$7/8$
6	14.00	1.88	8.50	11.50	1.12	12	1
8	16.50	2.19	10.62	13.75	1.25	12	$1-1/8$
10	20.00	2.50	12.75	17.00	1.38	16	$1-1/4$
12	22.00	2.62	15.00	19.25	1.38	20	$1-1/4$

Millimeters							
DN	A	B	C	D	E	F	G
50	165	25.4	92.1	127.0	19.1	8	15.9
65	190	28.6	104.8	149.4	22.4	8	19.1
80	210	31.8	127.0	168.3	22.4	8	19.1
100	275	38.1	157.2	215.9	25.4	8	22.2
150	355	47.7	215.9	292.1	28.4	12	25.4
200	420	55.6	269.9	349.2	31.8	12	28.6
250	510	63.5	323.8	431.8	35.1	16	31.8
300	560	66.7	381.0	489.0	35.1	20	31.8

Buttweld Dimensions (ASME B16.25)

Welding end details for joints without backing ring

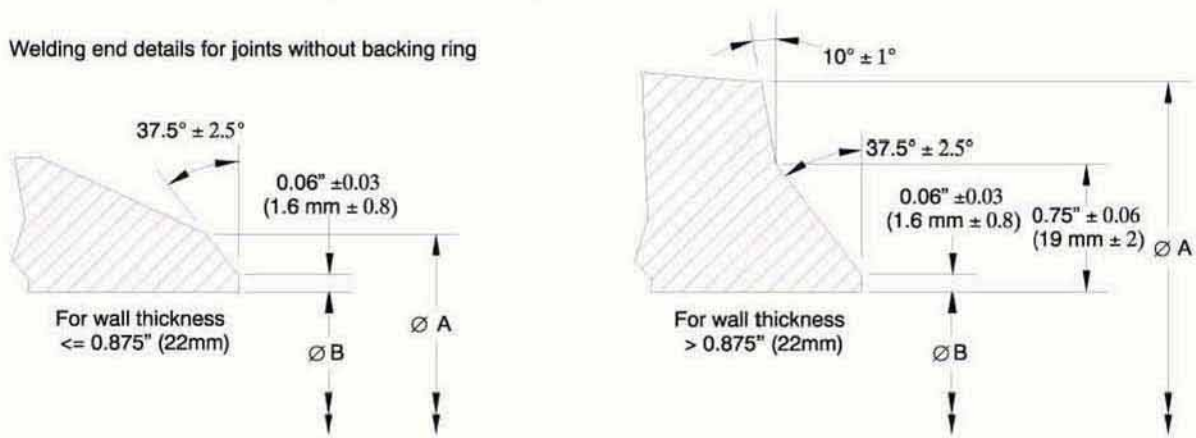

inches															
Size	Pipe OD	$\varnothing A$	$\varnothing B$ for Various Pipe Schedules												
			10	20	30	40	60	80	100	120	140	160	STD	XS	XXS
2.5	2.875	2.96	2.635			2.469		2.323				2.125	Sch 40	Sch 80	1.771
3	3.500	3.59	3.260			3.068		2.900				2.624	Sch 40	Sch 80	2.300
4	4.500	4.62	4.260			4.026		3.826		3.624		3.428	Sch 40	Sch 80	3.152
6	6.625	6.78	6.357			6.065		5.761		5.501		5.187			
8	8.625	8.78	8.329	8.125		7.981	7.813	7.625	7.437	7.187	7.001	6.813	Sch 40	Sch 80	6.875
10	10.750	10.94	10.420	10.250		10.020	9.750	9.562	9.312	9.062	8.750	8.500	Sch 40	Sch 60	Sch 140
12	12.750	12.97	12.390	12.250		11.938	11.626	11.374	11.062	10.750	10.500	10.126	12.000	11.750	Sch 120

millimeters															
DN	Pipe OD	$\varnothing A$	$\varnothing B$ for Various Pipe Schedules												
			10	20	30	40	60	80	100	120	140	160	STD	XS	XXS
65	73.03	75.2	66.93			62.71		59.00				53.98	Sch 40	Sch 80	44.98
80	88.90	91.2	82.80			77.93		73.66				66.65	Sch 40	Sch 80	58.42
100	114.30	117.3	108.20			102.26		97.18		92.05		87.07	Sch 40	Sch 80	80.06
150	168.28	172.2	161.47			154.05		146.33		139.73		131.75			
200	219.08	223.0	211.56	206.38		202.72	198.45	193.68	188.90	182.55	177.83	173.05	Sch 40	Sch 80	174.63
250	273.05	277.9	264.67	260.35		254.51	247.65	242.87	236.52	230.17	222.25	215.90	Sch 40	Sch 60	Sch 140
300	323.85	329.4	314.71	311.15		303.23	295.30	288.90	280.97	273.05	266.70	257.20	304.80	298.45	Sch 120

Product features - to our customers' benefit



Two piece self aligning gland

Your benefit

- Even compression of packing rings
- No distortion on stem surface due to improper assembly

Die-moulded graphite rings, top and bottom rings braided

Your benefit

- Prevents extrusion of graphite

Hardened back seat bushing

Your benefit

- Additional stem seal in full open position
- Blow-out protection

Valve seat made of wear and corrosion-resistant materials

Your benefit

- Long reliability
- Long life
- Seal facing

(Long service required)



Ni-Steel Stem Nut

Your benefit

- Corrosion resistant in ammonia atmosphere

Stem with burnished shank

Your benefit

- Long gland life
- Improved fugitive emissions performance
- Burnished stem 0.2um

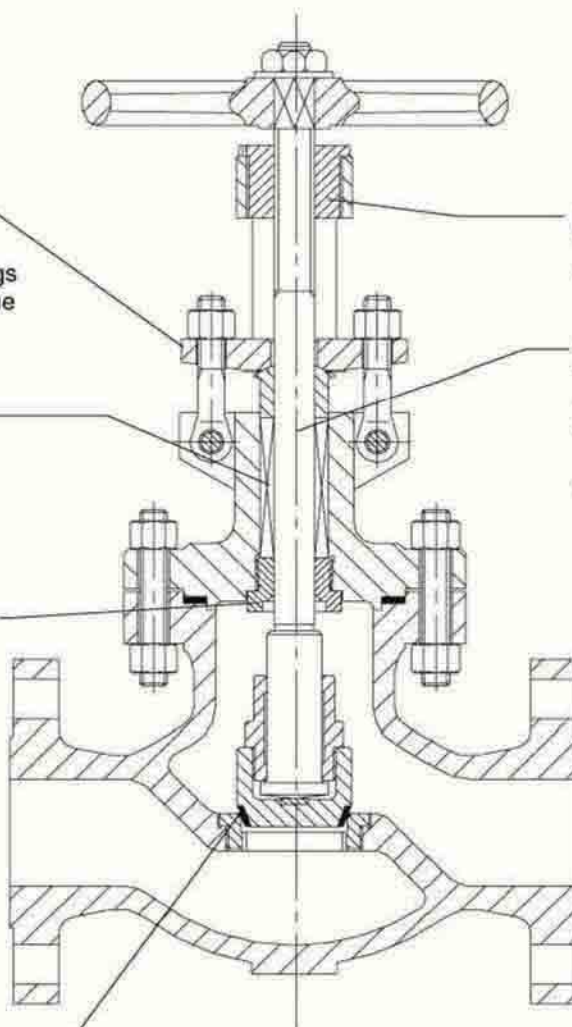

Subject to technical modification with out prior notice