

50/60 Hz



CONTROL PANELS

RANGE OF PANELS FOR CONTROL AND
PROTECTION OF LOWARA ELECTRIC PUMPS

CONTENTS

QSM Series	5
QPC Series	6
QPCS Series	7
QSC Series	8
QSC Series (60 Hz)	9
QSCS Series	10
QSCS Series (60 Hz)	11
QM Series	12
QTD Series	13
Q3D Series	14
Q3Y Series	15
Q3I Series	16
Q3A Series	17
Q3SF Series	18

QDRM Series	19
QDRMC Series	20
QDR Series	21
QGMC Series	22
QDRM2 Series	23
QYR Series	24
QDRMC2 Series	26
QDR2 Series	27
QYR2 Series	28
QXR20 Series	30
QCL5 Series	31
QCL10 Series	32
QCLP10 Series	33
KSL Series	34
DPF, VR, SCA3 Series	35
KIT RILS20 Series	36

Single-phase Electric Panel

APPLICATIONS

- Protection and control of a single-phase submersible electric pump for 4" wells

QSM Series



SPECIFICATIONS

- Main switch for manual control.
- Supply voltage: 1 x 220-240 V \pm 5%.
- Frequency: 50 Hz.
- Power: 0,25 to 1,1 kW.
- Direct motor start.
- Protection class: IP54.
- Ambient temperature: -5 to +40 °C (according to EN 60439-1).
- Maximum relative humidity: 50% at +40°C, provided that no condensation occurs (according to EN 60439-1).
- Wall mounted.
- Plastic enclosure.
- Incorporated capacitor.
- Thermal protection with motor protector inside the panel.

OPTIONAL FEATURES

- QSM PF version with overvoltage protection (lightning protector).

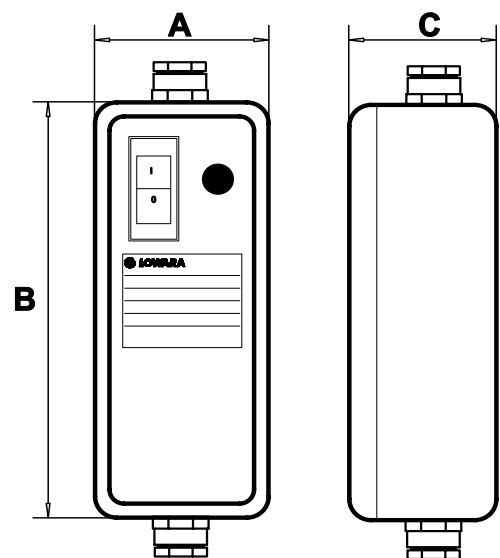

MODEL	RATED VOLTAGE V	RATED POWER		RATED CURRENT A	CAPACITOR 450V uF	DIMENSIONS			WEIGHT Kg
		kW	HP			A mm	B mm	C mm	
QSM 02	220-240	0,25	0,33	2,6	12,5	80	210	65	0,45
QSM 03	220-240	0,37	0,5	3,4	16	80	210	65	0,45
QSM 05	220-240	0,55	0,75	4,8	20	80	210	65	0,45
QSM 07	220-240	0,75	1	6,5	30	80	210	65	0,45
QSM 11	220-240	1,1	1,5	8,3	40	80	210	65	0,45

Single-phase Electric Panel

APPLICATIONS

- Protection and control of a single-phase submersible electric pump for 4" wells.

QPC Series



SPECIFICATIONS

- Main switch for manual control.
- Supply voltage: 1 x 230 V \pm 10%.
- Frequency: 50 Hz.
- Power: 0,25 to 2,2 kW.
- Direct motor start.
- Protection class: IP54.
- Ambient temperature: -5 to +40 °C (according to EN 60439-1).
- Maximum relative humidity: 50% at +40°C, provided that no condensation occurs (according to EN 60439-1).
- Wall mounted with fins.
- Plastic enclosure.
- Incorporated capacitor.
- Main switch with manual-reset thermal protection and power indicator light.

OPTIONAL ACCESSORIES

- DPF single-phase module for overvoltage protection (lightning protector).

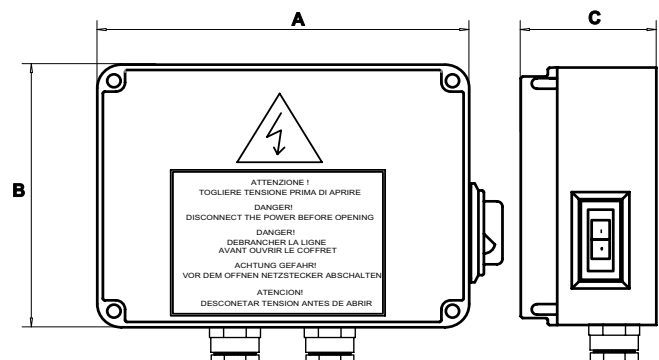

MODEL	RATED VOLTAGE V	RATED POWER		RATED CURRENT A	DIMENSIONS			WEIGHT Kg	CAPACITOR μ F/450V
		kW	HP		A mm	B mm	C mm		
QPC/02	1 x 230 V \pm 10 %	0,25	0,33	3	170	170	75	1,1	12,5
QPC/03	1 x 230 V \pm 10 %	0,37	0,5	4	170	170	75	1,1	16
QPC/05	1 x 230 V \pm 10 %	0,55	0,75	5	170	170	75	1,1	20
QPC/07	1 x 230 V \pm 10 %	0,75	1	6	170	170	75	1,1	30
QPC/11	1 x 230 V \pm 10 %	1,1	1,5	9	170	170	75	1,1	40
QPC/15	1 x 230 V \pm 10 %	1,5	2	11	170	170	75	1,1	50
QPC/22	1 x 230 V \pm 10 %	2,2	3	16	170	170	127	1,2	70

Single-phase Electric Panel

APPLICATIONS

- Protection and control of a single-phase submersible electric pump for 4" wells.

QPCS Series



SPECIFICATIONS

- Automatic control through an external enable contact.
- Supply voltage: 1 x 230 V \pm 10%.
- Frequency: 50 Hz.
- Power: 0,25 to 2,2 kW.
- 12 V AC low-voltage auxiliary circuit.
- Direct motor start.
- Protection class: IP54.
- Ambient temperature: -5 to +40 °C (according to EN 60439-1).
- Maximum relative humidity: 50% at +40°C, provided that no condensation occurs (according to EN 60439-1).
- Wall mounted with fins.
- Plastic enclosure with transparent cover.
- Incorporated capacitor.

- Main switch with manual-reset thermal protection and power indicator light.
- Power, pump running, level control LED.
- Overvoltage discharges.
- Dry running control through probes or float or minimum pressure switch.

OPTIONAL ACCESSORIES

- Set of 3 electrodes (probes) without cable.
- Float.
- Pressure switch.

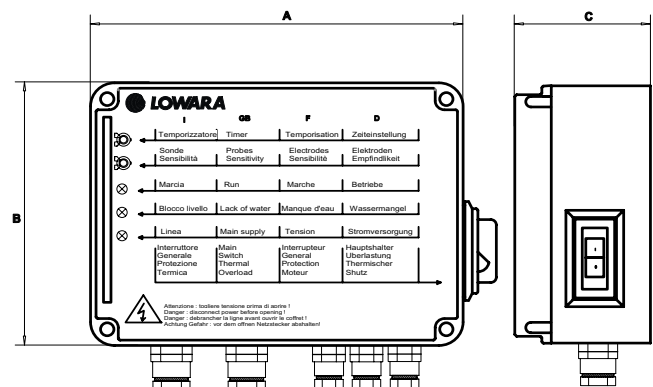

MODEL	RATED VOLTAGE V	RATED POWER		RATED CURRENT A	DIMENSIONS			WEIGHT Kg	CAPACITOR μ F/450V
		kW	HP		A	B	C		
QPCS/02	1 x 230 V \pm 10 %	0,25	0,33	3	200	150	80	1,3	12,5
QPCS/03	1 x 230 V \pm 10 %	0,37	0,5	4	200	150	80	1,3	16
QPCS/05	1 x 230 V \pm 10 %	0,55	0,75	5	200	150	80	1,3	20
QPCS/07	1 x 230 V \pm 10 %	0,75	1	6	200	150	80	1,3	30
QPCS/11	1 x 230 V \pm 10 %	1,1	1,5	9	200	150	80	1,3	40
QPCS/15	1 x 230 V \pm 10 %	1,5	2	11	200	150	80	1,3	50
QPCS/22	1 x 230 V \pm 10 %	2,2	3	16	200	150	80	1,3	70

Single-phase Electric Panel

APPLICATIONS

- Protection and control of a single-phase submersible electric pump for 4" wells.

QSC Series



SPECIFICATIONS

- Main switch for manual control.
- Supply voltage: 1 x 230 V \pm 10%.
- Frequency: 50 Hz.
- Power: 0,25 to 4 kW.
- Direct motor start.
- Protection class: IP55.
- Ambient temperature: -5 to +40 °C (according to EN 60439-1).
- Maximum relative humidity: 50% at +40°C, provided that no condensation occurs (according to EN 60439-1).
- Wall mounted.
- Plastic enclosure.
- Incorporated capacitor.
- Main switch with manual-reset thermal protection.

OPTIONAL ACCESSORIES

- DPF single-phase module for overvoltage protection (lightning protector).

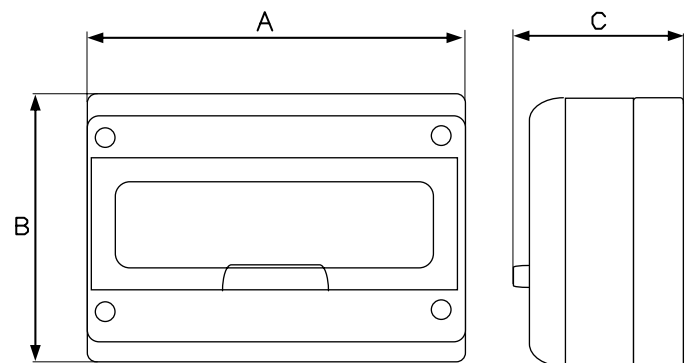

MODEL	RATED VOLTAGE V	RATED POWER		RATED CURRENT A	DIMENSIONS			WEIGHT Kg	CAPACITOR μ F/450V
		kW	HP		A mm	B mm	C mm		
QSC/02	1 x 230 V \pm 10 %	0,25	0,33	2,5 \div 4	205	220	160	1,7	12,5
QSC/03	1 x 230 V \pm 10 %	0,37	0,5	4 \div 6,3	205	220	160	1,7	16
QSC/05	1 x 230 V \pm 10 %	0,55	0,75	4 \div 6,3	205	220	160	1,7	20
QSC/07	1 x 230 V \pm 10 %	0,75	1	4 \div 6,3	205	220	160	1,7	30
QSC/11	1 x 230 V \pm 10 %	1,1	1,5	6,3 \div 10	205	220	160	1,7	40
QSC/15	1 x 230 V \pm 10 %	1,5	2	10 \div 16	205	220	160	1,7	50
QSC/22	1 x 230 V \pm 10 %	2,2	3	16 \div 20	205	220	160	2,7	70
QSC/40	1 x 230 V \pm 10 %	4	5,5	25 \div 32	280	220	160	3	90

CB-QSC-en_d_te

Single-phase Electric Panel

APPLICATIONS

- Protection and control of a single-phase submersible electric pump for 4" wells.

QSC Series (60 Hz)



SPECIFICATIONS

- Main switch for manual control.
- Supply voltage: 1 x 230 V \pm 10%.
- Frequency: 60 Hz.
- Power: 0,37 to 4 kW.
- Direct motor start.
- Protection class: IP55.
- Ambient temperature: -5 to +40 °C (according to EN 60439-1).
- Maximum relative humidity: 50% at +40°C, provided that no condensation occurs (according to EN 60439-1).
- Wall mounted.
- Plastic enclosure.
- Incorporated capacitor.
- Main switch with thermal protection.

OPTIONAL ACCESSORIES

- DPF single-phase module for overvoltage protection (lightning protector).

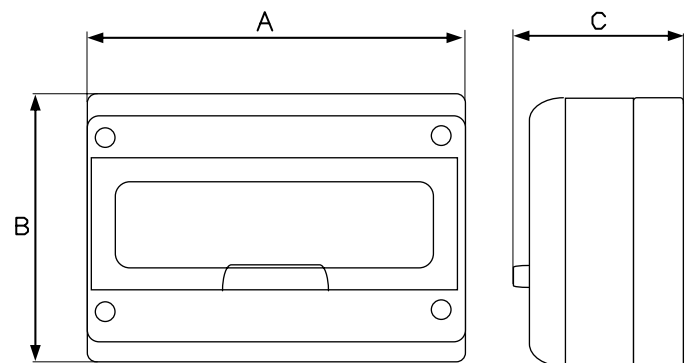

MODEL	RATED VOLTAGE V	RATED POWER		RATED CURRENT A	DIMENSIONS			WEIGHT Kg	CAPACITOR μ F/450V
		kW	HP		A mm	B mm	C mm		
QSC/036	1 x 230 V \pm 10 %	0,37	0,5	4 \div 6,3	205	220	160	1,7	20
QSC/056	1 x 230 V \pm 10 %	0,55	0,75	4 \div 6,3	205	220	160	1,7	25
QSC/056A	1 x 230 V \pm 10 %	0,55	0,75	6,3 \div 10	205	220	160	1,7	25
QSC/076	1 x 230 V \pm 10 %	0,75	1	6,3 \div 10	205	220	160	1,7	35
QSC/116	1 x 230 V \pm 10 %	1,1	1,5	6,3 \div 10	205	220	160	1,7	40
QSC/116A	1 x 230 V \pm 10 %	1,1	1,5	10 \div 16	205	220	160	1,7	40
QSC/156	1 x 230 V \pm 10 %	1,5	2	10 \div 16	205	220	160	1,7	50
QSC/226	1 x 230 V \pm 10 %	2,2	3	16 \div 20	205	220	160	2,7	50
QSC/406	1 x 230 V \pm 10 %	4	5,5	25 \div 32	280	220	160	3	75

Single-phase Electric Panel

APPLICATIONS

- Protection and control of a single-phase submersible electric pump for 4" wells.

QSCS Series



SPECIFICATIONS

- Automatic control through an external enable contact.
- Supply voltage: 1 x 230 V \pm 10%.
- Frequency: 50 Hz.
- Power: 0,25 to 2,2 kW.
- Direct motor start.
- Protection class: IP55.
- Ambient temperature: -5 to +40 °C (according to EN 60439-1).
- Maximum relative humidity: 50% at +40°C, provided that no condensation occurs (according to EN 60439-1).
- Wall mounted.
- Plastic enclosure.
- Incorporated capacitor.

- Main switch with manual-reset thermal protection.
- Dry running control with float or minimum pressure switch (available separately).

OPTIONAL ACCESSORIES

- DPF single-phase module for overvoltage protection (lightning protector).
- KSL series 24 V level kit. Probe module for protection against dry running (set of three electrodes included in the supply).

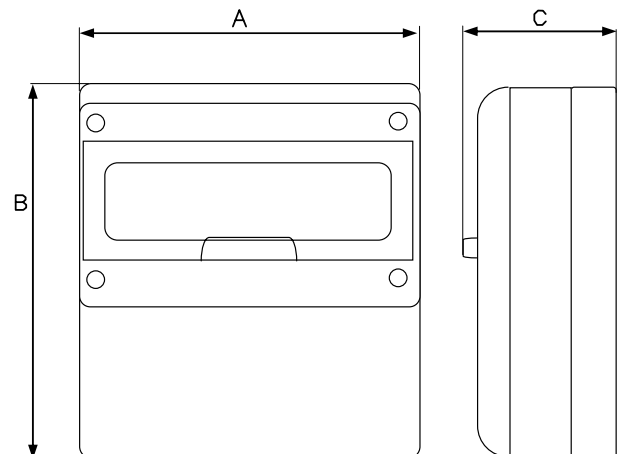

MODEL	RATED VOLTAGE V	RATED POWER		RATED CURRENT A	DIMENSIONS			WEIGHT Kg	CAPACITOR μ F/450V
		kW	HP		A mm	B mm	C mm		
QSCS/02	1 x 230 V \pm 10 %	0,25	0,33	2,5 \div 4	280	370	160	3,7	12,5
QSCS/03	1 x 230 V \pm 10 %	0,37	0,5	4 \div 6,3	280	370	160	3,7	16
QSCS/05	1 x 230 V \pm 10 %	0,55	0,75	4 \div 6,3	280	370	160	3,7	20
QSCS/07	1 x 230 V \pm 10 %	0,75	1	4 \div 6,3	280	370	160	3,7	30
QSCS/11	1 x 230 V \pm 10 %	1,1	1,5	6,3 \div 10	280	370	160	3,7	40
QSCS/15	1 x 230 V \pm 10 %	1,5	2	10 \div 16	280	370	160	3,7	50
QSCS/22	1 x 230 V \pm 10 %	2,2	3	16 \div 20	280	370	160	3,7	70
QSCS/40	1 x 230 V \pm 10 %	4	5,5	25 \div 32	280	370	160	4	90

Single-phase Electric Panel

APPLICATIONS

- Protection and control of a single-phase submersible electric pump for 4" wells.

QSCS Series (60 Hz)



SPECIFICATIONS

- Automatic control through an external enable contact.
- Supply voltage: 1 x 230 V \pm 10%.
- Frequency: 60 Hz.
- Power: 0,37 to 2,2 kW.
- Direct motor start.
- Protection class: IP55.
- Ambient temperature: -5 to +40 °C (according to EN 60439-1).
- Maximum relative humidity: 50% at +40°C, provided that no condensation occurs (according to EN 60439-1).
- Wall mounted.
- Plastic enclosure.
- Incorporated capacitor.

- Main switch with thermal protection.
- Dry running control with float or minimum pressure switch (available separately).

OPTIONAL ACCESSORIES

- DPF single-phase module for overvoltage protection (lightning protector).
- KSL series 24 V level kit. Probe module for protection against dry running (set of three electrodes included in the supply).

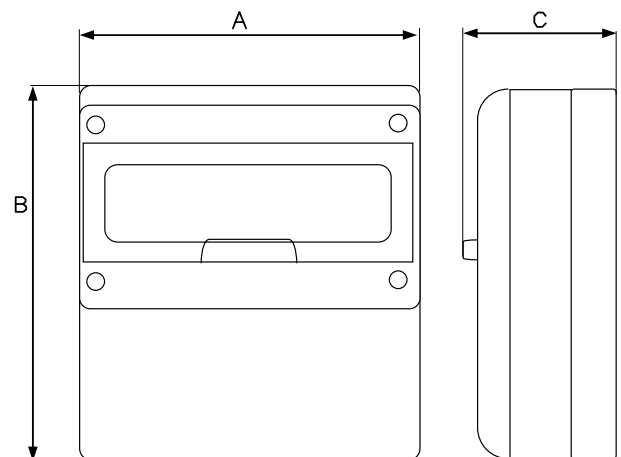

MODEL	RATED VOLTAGE V	RATED POWER		RATED CURRENT A	DIMENSIONS			WEIGHT Kg	CAPACITOR μ F/450V
		kW	HP		A mm	B mm	C mm		
QSCS/036	1 x 230 V \pm 10 %	0,37	0,5	4 \div 6,3	280	370	160	3,7	20
QSCS/056	1 x 230 V \pm 10 %	0,55	0,75	4 \div 6,3	280	370	160	3,7	25
QSCS/056A	1 x 230 V \pm 10 %	0,55	0,75	6,3 \div 10	280	370	160	3,7	25
QSCS/076	1 x 230 V \pm 10 %	0,75	1	6,3 \div 10	280	370	160	3,7	35
QSCS/116	1 x 230 V \pm 10 %	1,1	1,5	6,3 \div 10	280	370	160	3,7	40
QSCS/116A	1 x 230 V \pm 10 %	1,1	1,5	10 \div 16	280	370	160	3,7	40
QSCS/156	1 x 230 V \pm 10 %	1,5	2	10 \div 16	280	370	160	3,7	50
QSCS/226	1 x 230 V \pm 10 %	2,2	3	16 \div 20	280	370	160	3,7	50
QSCS/406	1 x 230 V \pm 10 %	4	5,5	25 \div 32	280	370	160	4	75

Single-phase Electric Panel

APPLICATIONS

- Protection and control of a single-phase surface electric pump.

QM Series



SPECIFICATIONS

- Automatic control through an external enable contact.
- Supply voltage: 1 x 230 V \pm 10%.
- Frequency: 50/60 Hz.
- Power: 0,25 to 2,2 kW.
- Direct motor start.
- Protection class: IP54.
- Ambient temperature: -5 to +40 °C (according to EN 60439-1).
- Maximum relative humidity: 50% at +40°C, provided that no condensation occurs (according to EN 60439-1).
- Wall mounted.
- Metal enclosure.
- Ready for installation of dry running control float or pressure switch (to be ordered separately).
- Power and thermal overload indicator lights

OPTIONAL ACCESSORIES

- VR1 single-phase varistor module overvoltage protection (lightning protector).
- KSL series 24 V level kit. Probe module for protection against dry running (set of three electrodes included in the supply).

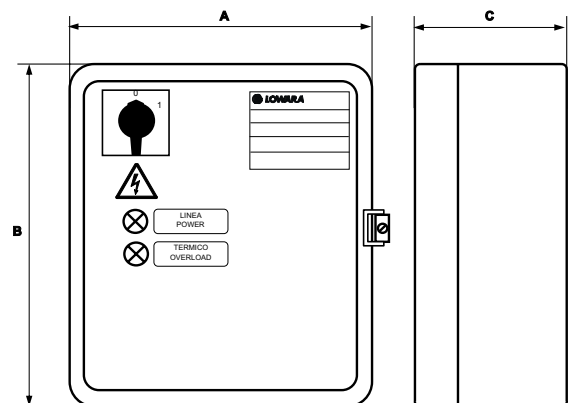

MODEL	RATED VOLTAGE V	RATED POWER		RATED CURRENT A	DIMENSIONS			WEIGHT Kg
		kW	HP		A mm	B mm	C mm	
QM/02	1 x 230 V \pm 10 %	0,25	0,33	1 \div 1,6	235	265	150	5,8
QM/03	1 x 230 V \pm 10 %	0,37	0,5	1,6 \div 2,5	235	265	150	5,8
QM/05	1 x 230 V \pm 10 %	0,55	0,75	2,5 \div 4	235	265	150	5,8
QM/07	1 x 230 V \pm 10 %	0,75	1	4 \div 6,3	235	265	150	5,8
QM/15	1 x 230 V \pm 10 %	1,5	2	6,3 \div 10	235	265	150	5,8
QM/22	1 x 230 V \pm 10 %	2,2	3	10 \div 16	235	265	150	5,8

CB-QM-en_b_te

Three-phase Electric Panel

APPLICATIONS

- Protection and control of a three-phase surface or submersible electric pump.

QTD Series



SPECIFICATIONS

- Control through an external enable contact.
- Supply voltage: 3 x 400 V \pm 10%.
- Frequency: 50/60 Hz.
- Power: 0,25 to 9,2 kW.
- Direct motor start.
- Short-circuit and overload protection.
- Protection class: IP54.
- Ambient temperature: -5 to +40 °C (according to EN 60439-1).
- Maximum relative humidity: 50% at +40°C, provided that no condensation occurs (according to EN 60439-1).
- Wall mounted.
- Metal enclosure.
- Ready for installation of dry running control float or pressure switch (to be ordered separately).
- Power and thermal overload indicator lights.

OPTIONAL ACCESSORIES

- VR3 three-phase module for overvoltage protection (lightning protector).
- KSL series 24 V level kit. Probe module for protection against dry running (set of three electrodes included in the supply).

SELECTION

- For a suitable choice of control panel, be sure the electrical input of the motor (Ampere) is included in the rated current value mentioned in the table below.

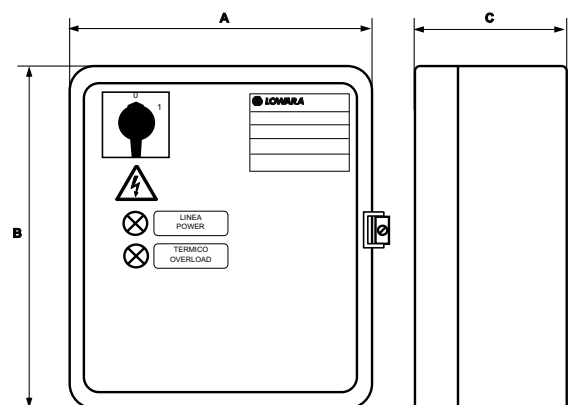

MODEL	RATED VOLTAGE V	RATED POWER		RATED CURRENT A	DIMENSIONS			WEIGHT Kg
		kW	HP		A mm	B mm	C mm	
QTD/02-03	3 x 400 V \pm 10 %	0,25-0,37	0,33-0,50	0,63 ÷ 1	235	265	150	5,8
QTD/03-05	3 x 400 V \pm 10 %	0,37-0,55	0,55-0,75	1 ÷ 1,6	235	265	150	5,8
QTD/05-07	3 x 400 V \pm 10 %	0,55-0,75	0,75-1	1,6 ÷ 2,5	235	265	150	5,8
QTD/07-15	3 x 400 V \pm 10 %	0,75-1,5	1-2	2,5 ÷ 4	235	265	150	5,8
QTD/15-22	3 x 400 V \pm 10 %	1,5-2,2	2-3	4 ÷ 6,3	235	265	150	5,8
QTD/22-40	3 x 400 V \pm 10 %	2,2-4	3-5,5	6,3 ÷ 10	235	265	150	5,8
QTD/40-75	3 x 400 V \pm 10 %	4-7,5	5,5-10	10 ÷ 16	235	265	150	5,8
QTD/75-92	3 x 400 V \pm 10 %	7,5-9,2	10-12,5	16 ÷ 20	235	265	150	5,8

Three-phase Electric Panel

APPLICATIONS

- Protection and control of a three-phase surface or submersible electric pump.

Q3D Series



SPECIFICATIONS

- Manual control through an Auto/Man selector switch.
- Automatic control through an external enable contact.
- Supply voltage: 3 x 400 V \pm 10%.
- Frequency: 50/60 Hz.
- 24 V AC low voltage auxiliary circuit.
- Power: 0,25 to 37 kW.
- Direct motor start.
- Short-circuit and overload protection.
- Protection class: IP54.
- Ambient temperature: -5 to +40 °C (according to EN 60439-1).
- Maximum relative humidity: 50% at +40°C, provided that no condensation occurs (according to EN 60439-1).
- Wall mounted.
- Metal enclosure.
- Power, pump running, thermal overload and dry running indicator lights.

- Ready for installation of dry running control float or pressure switch (to be ordered separately). Can be equipped with electronic protection module with electrodes.

OPTIONAL ACCESSORIES

- KSL series 24 V level kit. Probe module for protection against dry running (set of three electrodes included in the supply).
- Float.
- Pressure switch.
- VR3/SCA3 three-phase module for overvoltage protection (lightning protector).

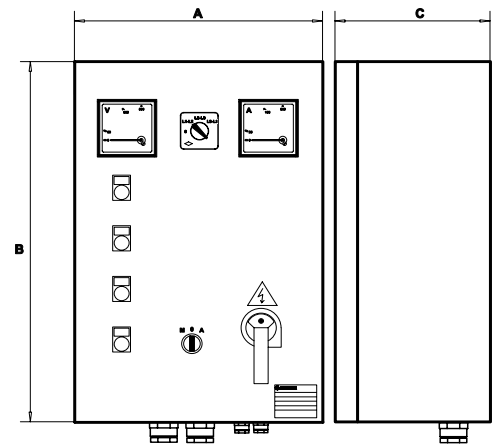

MODEL	RATED VOLTAGE V	RATED POWER		RATED CURRENT A	DIMENSIONS			WEIGHT Kg
		kW	HP		A mm	B mm	C mm	
Q3D/02-03	3 x 400 V \pm 10 %	0,25-0,37	0,33-0,50	0,63 \div 1	300	400	200	15
Q3D/03-05	3 x 400 V \pm 10 %	0,37-0,55	0,5-0,75	1 \div 1,6	300	400	200	15
Q3D/05-07	3 x 400 V \pm 10 %	0,55-0,75	0,75-1	1,6 \div 2,5	300	400	200	15
Q3D/07-15	3 x 400 V \pm 10 %	0,75-1,5	1-2	2,5 \div 4	300	400	200	15
Q3D/15-22	3 x 400 V \pm 10 %	1,5-2,2	2-3	4 \div 6,3	300	400	200	15
Q3D/22-40	3 x 400 V \pm 10 %	2,2-4	3-5,5	6,3 \div 10	300	400	200	15
Q3D/40-75	3 x 400 V \pm 10 %	4-7,5	5,5-10	10 \div 16	300	400	200	15
Q3D/75-92	3 x 400 V \pm 10 %	7,5-9,2	10-12,5	16 \div 20	300	400	200	15
Q3D/92-110	3 x 400 V \pm 10 %	9,2-11	12,5-15	20 \div 25	300	400	200	20
Q3D/110-150	3 x 400 V \pm 10 %	11-15	15-20	22 \div 32	400	500	200	20
Q3D/150-185	3 x 400 V \pm 10 %	15-18,5	20-25	28 \div 40	400	500	200	20
Q3D/185-220	3 x 400 V \pm 10 %	18,5-22	25-30	36 \div 50	400	600	200	27
Q3D/220-300	3 x 400 V \pm 10 %	22-30	30-40	45 \div 63	400	600	200	27
Q3D/300-370	3 x 400 V \pm 10 %	30-37	40-50	57 \div 75	400	600	200	27

Three-phase Electric Panel

Q3Y Series



APPLICATIONS

- Protection and control of a three-phase surface or submersible electric pump.

SPECIFICATIONS

- Manual control through an Auto/Man selector switch.
- Automatic control through an external enable contact.
- Supply voltage: 3 x 400 V \pm 10%.
- Frequency: 50/60 Hz.
- 24 V AC low voltage auxiliary circuit.
- Power: 4 to 315 kW.
- Star-delta starting.
- Short-circuit and overload protection.
- Protection class: IP54.
- Ambient temperature: -5 to +40 °C (according to EN 60439-1).
- Maximum relative humidity: 50% at +40°C, provided that no condensation occurs (according to EN 60439-1).
- Wall mounted.
- Metal enclosure.
- Power, pump running, thermal overload and dry running indicator lights.

- Ready for installation of dry running control float or pressure switch (to be ordered separately). Can be equipped with electronic protection module with electrodes.

OPTIONAL ACCESSORIES

- KSL series 24 V level kit. Probe module for protection against dry running (set of three electrodes included in the supply).
- Float.
- Pressure switch.
- VR3/SCA3 three-phase module for overvoltage protection (lightning protector).

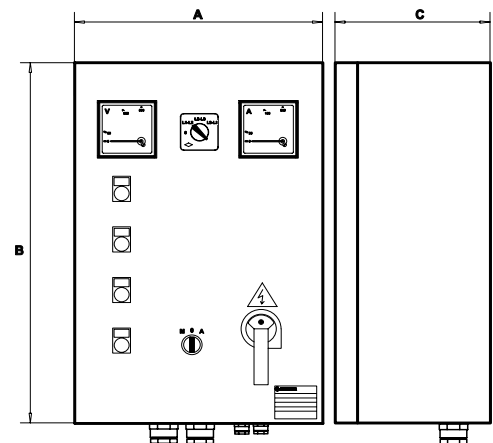

MODEL	RATED VOLTAGE V	RATED POWER		RATED CURRENT A	DIMENSIONS			WEIGHT Kg
		kW	HP		A mm	B mm	C mm	
Q3Y/40-75	3 x 400 V \pm 10 %	4-7,5	5,5-10	10 \div 16	400	600	200	23
Q3Y/75-92	3 x 400 V \pm 10 %	7,5-9,2	10-12,5	16 \div 20	400	600	200	23
Q3Y/92-110	3 x 400 V \pm 10 %	9,2-11	12,5-15	20 \div 25	400	600	200	23
Q3Y/110-150	3 x 400 V \pm 10 %	11-15	15-20	22 \div 32	400	600	200	23
Q3Y/150-185	3 x 400 V \pm 10 %	15-18,5	20-25	28 \div 40	400	600	200	23
Q3Y/185-220	3 x 400 V \pm 10 %	18,5-22	25-30	36 \div 50	500	700	200	32
Q3Y/220-300	3 x 400 V \pm 10 %	22-30	30-40	45 \div 63	500	700	200	32
Q3Y/300-370	3 x 400 V \pm 10 %	30-37	40-50	57 \div 75	600	800	250	68
Q3Y/370-450	3 x 400 V \pm 10 %	37-45	50-60	70 \div 90	600	800	250	80
Q3Y/450-550	3 x 400 V \pm 10 %	45-55	60-75	80 \div 108	600	900	250	80
Q3Y/550-750	3 x 400 V \pm 10 %	55-75	75-100	105 \div 138	600p	1300p	300p	109
Q3Y/750-900	3 x 400 V \pm 10 %	75-90	100-125	138 \div 185	600p	1300p	300p	109
Q3Y/900-1100	3 x 400 V \pm 10 %	90-110	125-150	175 \div 210	600p	1500p	300p	120
Q3Y/1100-1320	3 x 400 V \pm 10 %	110-132	150-180	210 \div 260	800p	1700p	400p	130
Q3Y/1320-1600	3 x 400 V \pm 10 %	132-160	180-218	250 \div 305	800p	1700p	400p	130
Q3Y/1600-2000	3 x 400 V \pm 10 %	160-200	218-273	290 \div 400	800p	1900p	400p	140
Q3Y/2000-2500	3 x 400 V \pm 10 %	200-250	273-340	400 \div 460	1000p	1900p	400p	180
Q3Y/2500-3150	3 x 400 V \pm 10 %	250-315	340-430	450 \div 580	1000p	1900p	400p	180

Dimensions note : P indicates floor mounted control panel.

CB-Q3Y-en_c_te

Three-phase Electric Panel

Q3I Series



APPLICATIONS

- Protection and control of a three-phase surface or submersible electric pump.

SPECIFICATIONS

- Manual control through an Auto/Man selector switch.
- Automatic control through an external enable contact.
- Supply voltage: 3 x 400 V \pm 10%.
- Frequency: 50/60 Hz.
- 24 V AC low voltage auxiliary circuit.
- Power: 4 to 315 kW.
- Impedance start.
- Short-circuit and overload protection.
- Protection class: IP54.
- Ambient temperature: -5 to +40 °C (according to EN 60439-1).
- Maximum relative humidity: 50% at +40°C, provided that no condensation occurs (according to EN 60439-1).
- Wall mounted.
- Metal enclosure.
- Power, pump running, thermal overload and dry running indicator lights.

- Ready for installation of dry running control float or pressure switch (to be ordered separately). Can be equipped with electronic protection module with electrodes.

OPTIONAL ACCESSORIES

- KSL series 24 V level kit. Probe module for protection against dry running (set of three electrodes included in the supply).
- Float.
- Pressure switch.
- VR3/SCA3 three-phase module for overvoltage protection (lightning protector).

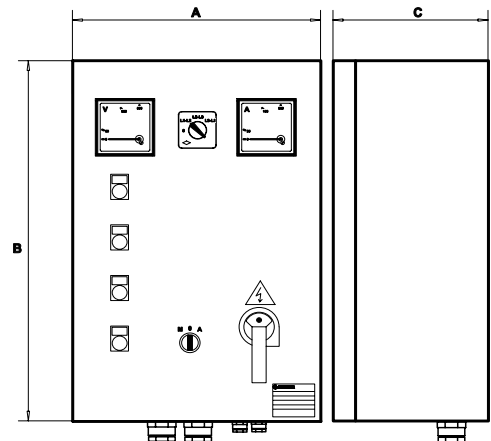

MODEL	RATED VOLTAGE V	RATED POWER		RATED CURRENT A	DIMENSIONS			WEIGHT Kg
		kW	HP		A mm	B mm	C mm	
Q3I/40-75	3 x 400 V \pm 10 %	4-7,5	5,5-10	10 \div 16	400	600	250	35
Q3I/75-92	3 x 400 V \pm 10 %	7,5-9,2	10-12,5	16 \div 20	400	600	250	35
Q3I/92-110	3 x 400 V \pm 10 %	9,2-11	12,5-15	20 \div 25	400	600	250	35
Q3I/110-150	3 x 400 V \pm 10 %	11-15	15-20	22 \div 32	500	700	250	50
Q3I/150-185	3 x 400 V \pm 10 %	15-18,5	20-25	28 \div 40	500	700	250	50
Q3I/185-220	3 x 400 V \pm 10 %	18,5-22	25-30	36 \div 50	500	700	250	50
Q3I/220-300	3 x 400 V \pm 10 %	22-30	30-40	45 \div 63	500	700	250	65
Q3I/300-370	3 x 400 V \pm 10 %	30-37	40-50	57 \div 75	500	700	250	65
Q3I/370-450	3 x 400 V \pm 10 %	37-45	50-60	70 \div 90	600	900	250	65
Q3I/450-550	3 x 400 V \pm 10 %	45-55	60-75	80 \div 108	600p	1300p	300p	100
Q3I/550-750	3 x 400 V \pm 10 %	55-75	75-100	105 \div 138	600p	1300p	300p	100
Q3I/750-900	3 x 400 V \pm 10 %	75-90	100-125	138 \div 185	600p	1500p	300p	100
Q3I/900-1100	3 x 400 V \pm 10 %	90-110	125-150	175 \div 210	800p	1700p	400p	100
Q3I/1100-1320	3 x 400 V \pm 10 %	110-132	150-180	210 \div 260	800p	1700p	400p	150
Q3I/1320-1600	3 x 400 V \pm 10 %	132-160	180-218	250 \div 305	800p	1700p	400p	150
Q3I/1600-2000	3 x 400 V \pm 10 %	160-200	218-273	290 \div 400	800p	1900p	400p	160
Q3I/2000-2500	3 x 400 V \pm 10 %	200-250	273-340	400 \div 460	1000p	1900p	400p	180
Q3I/2500-3150	3 x 400 V \pm 10 %	250-315	340-430	450 \div 580	1000p	1900p	400p	200

Dimensions note : P indicates floor mounted control panel.

CB-Q3I-en_c_te

Three-phase Electric Panel

Q3A Series



APPLICATIONS

- Protection and control of a three-phase surface or submersible electric pump.

SPECIFICATIONS

- Manual control through an Auto/Man selector switch.
- Automatic control through an external enable contact.
- Supply voltage: 3 x 400 V \pm 10%.
- Frequency: 50/60 Hz.
- 24 V AC low voltage auxiliary circuit.
- Power: 4 to 315 kW.
- Starting autotransformer.
- Short-circuit and overload protection.
- Protection class: IP54.
- Ambient temperature: -5 to +40 °C (according to EN 60439-1).
- Maximum relative humidity: 50% at +40°C, provided that no condensation occurs (according to EN 60439-1).
- Wall mounted.
- Metal enclosure.
- Power, pump running, thermal overload and dry running indicator lights.

- Ready for installation of dry running control float or pressure switch (to be ordered separately). Can be equipped with electronic protection module with electrodes.

OPTIONAL ACCESSORIES

- KSL series 24 V level kit. Probe module for protection against dry running (set of three electrodes included in the supply).
- Float.
- Pressure switch.
- VR3/SCA3 three-phase module for overvoltage protection (lightning protector).

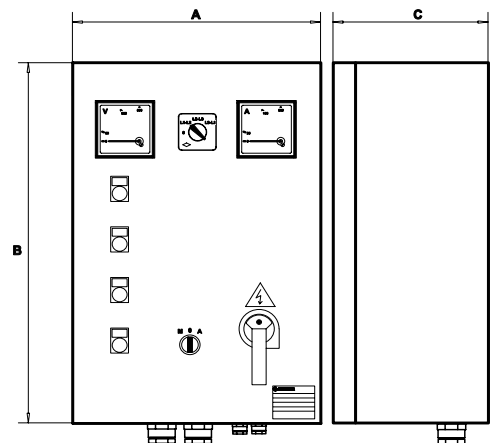

MODEL	RATED VOLTAGE V	RATED POWER		RATED CURRENT A	DIMENSIONS			WEIGHT Kg
		kW	HP		A mm	B mm	C mm	
Q3A/40-75	3 x 400 V \pm 10 %	4-7,5	5,5-10	10 \div 16	500	700	250	50
Q3A/75-92	3 x 400 V \pm 10 %	7,5-9,2	10-12,5	16 \div 20	500	700	250	50
Q3A/92-110	3 x 400 V \pm 10 %	9,2-11	12,5-15	20 \div 25	500	700	250	50
Q3A/110-150	3 x 400 V \pm 10 %	11-15	15-20	22 \div 32	500	700	250	50
Q3A/150-185	3 x 400 V \pm 10 %	15-18,5	20-25	28 \div 40	500	700	250	50
Q3A/185-220	3 x 400 V \pm 10 %	18,5-22	25-30	36 \div 50	500	700	250	50
Q3A/220-300	3 x 400 V \pm 10 %	22-30	30-40	45 \div 63	600	900	300	80
Q3A/300-370	3 x 400 V \pm 10 %	30-37	40-50	57 \div 75	600	900	300	80
Q3A/370-450	3 x 400 V \pm 10 %	37-45	50-60	70 \div 90	600p	1300p	300p	90
Q3A/450-550	3 x 400 V \pm 10 %	45-55	60-75	80 \div 108	600p	1500p	300p	120
Q3A/550-750	3 x 400 V \pm 10 %	55-75	75-100	105 \div 138	600p	1500p	300p	120
Q3A/750-900	3 x 400 V \pm 10 %	75-90	100-125	138 \div 185	600p	1700p	400p	150
Q3A/900-1100	3 x 400 V \pm 10 %	90-110	125-150	175 \div 210	800p	1900p	400p	150
Q3A/1100-1320	3 x 400 V \pm 10 %	110-132	150-180	210 \div 260	800p	1900p	400p	200
Q3A/1320-1600	3 x 400 V \pm 10 %	132-160	180-218	250 \div 305	800p	1900p	400p	200
Q3A/1600-2000	3 x 400 V \pm 10 %	160-200	218-273	290 \div 400	800p	1900p	400p	230
Q3A/2000-2500	3 x 400 V \pm 10 %	200-250	273-340	400 \div 460	1000p	1900p	400p	230
Q3A/2500-3150	3 x 400 V \pm 10 %	250-315	340-430	450 \div 580	1000p	1900p	400p	250

Dimensions note : P indicates floor mounted control panel.

CB-Q3A-en_c_te

Three-phase Electric Panel

Q3SF Series



APPLICATIONS

- Protection and control of a three-phase surface or submersible electric pump.

SPECIFICATIONS

- Manual control through an Auto/Man selector switch.
- Automatic control through an external enable contact.
- Supply voltage: 3 x 400 V \pm 10%.
- Frequency: 50/60 Hz.
- 24 V AC low voltage auxiliary circuit.
- Power: 5,5 to 110 kW.
- Softstart with torque control.
- Protection class: IP54.
- Ambient temperature: -5 to +40 °C
- Maximum relative humidity: 50% at +40°C, provided that no condensation occurs (according to EN 60439-1).
- Wall mounted.
- Metal enclosure.
- Dry running indicator light.
- Power - pump running - malfunction LEDs on starter keypad.
- ON/OFF selector switch for activation of by-pass contactor.
- Ready for installation of dry running control float or pressure switch (to be ordered separately). Can be equipped with electronic protection module with electrodes.

Protections against phase failure / phase sequence / frequency out of limits on power supply line.
 Low-voltage protection on auxiliary circuits.
 Protection against starter overtemperature / overload / malfunction.
 Protection against overload / locked rotor / current asymmetry on motor side.
 Short-circuit protection on inputs and outputs.
 RS232 interface for remote control and RS485 for use of remote keypad.
 Incorporated by-pass contactor.

OPTIONAL ACCESSORIES

- KSL series 24 V level kit. Probe module for protection against dry running (set of three electrodes included in the supply).
- Float.
- Pressure switch.
- VR3/SCA3 three-phase module for overvoltage protection (lightning protector).

STATIC STARTER CHARACTERISTICS

- Static starter for gradual start-up/shutdown, featuring: keypad with liquid crystal display showing voltage, absorbed current, $\cos \Phi$, operating hours, number of starts, last twenty messages on system status (events / alarms).

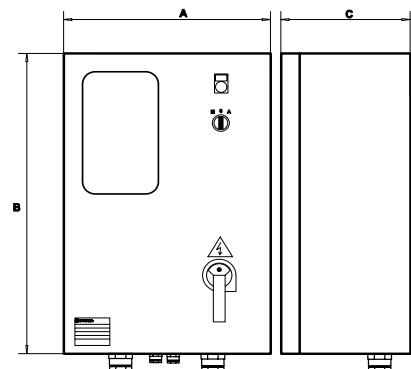

MODEL	RATED VOLTAGE V	RATED POWER		RATED CURRENT A	DIMENSIONS			WEIGHT Kg
		kW	HP		A mm	B mm	C mm	
Q3SF 75	3 x 400 V \pm 10 %	5,5 - 7,5	7,5 - 10	8,5 \div 17	400	600	250	35
Q3SF 150	3 x 400 V \pm 10 %	9,2 - 15	12,5 - 20	15 \div 30	500	700	250	40
Q3SF 220	3 x 400 V \pm 10 %	18,5 - 22	25 - 30	28 \div 45	500	700	250	40
Q3SF 300	3 x 400 V \pm 10 %	30	40	42 \div 60	600	900	300	90
Q3SF 370	3 x 400 V \pm 10 %	37	50	55 \div 75	600	900	300	90
Q3SF 450	3 x 400 V \pm 10 %	45	60	70 \div 85	600	900	300	90
Q3SF 550	3 x 400 V \pm 10 %	55	75	80 \div 110	600	900	300	90
Q3SF 590	3 x 400 V \pm 10 %	59	80	105 \div 125	600	900	300	90
Q3SF 750	3 x 400 V \pm 10 %	75	100	120 \div 142	600p	1700p	400p	120
Q3SF 900	3 x 400 V \pm 10 %	90	125	135 \div 190	600p	1700p	400p	120
Q3SF 1100	3 x 400 V \pm 10 %	110	150	185 \div 245	600p	1700p	400p	120

Dimensions note : P indicates floor mounted control panel.

CB-Q3SF-en_b_te

Electrical panel for drainage pumps

QDRM Series single-phase



APPLICATIONS

- Protection and control of one single-phase drainage pump.

SPECIFICATIONS

- Automatic control through electromechanical floats.
- Power supply voltage: 1 x 230 V \pm 10%.
- Frequency: 50/60 Hz.
- Power: 0,25 to 2,2 kW.
- Direct motor start.
- Protection class: IP55
- Ambient temperature: -5 to +40 °C (according to EN 60439-1).
- Maximum relative humidity: 50% at +40°C, provided that no condensation occurs (according to EN 60439-1).
- Wall mounted.
- Plastic enclosure.
- Electronic control module with test and alarm reset buttons, and power-on, pump running and high level alarm indicator LED's.
- Alarm silencing button.

OPTIONAL ACCESSORIES

- Audible or visual signalling device, 12 Vdc 0.3 A max (two connection terminals provided inside the electrical panel) for high-level alarm.
- VR1 single-phase module (for QDRM) for overvoltage protection (lightning protector).

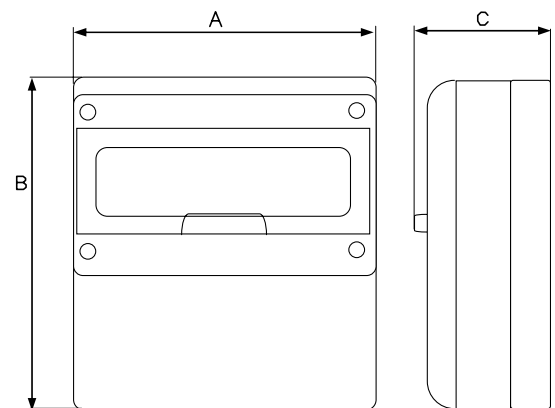

MODEL	RATED VOLTAGE V	RATED POWER		RATED CURRENT A	DIMENSIONS			WEIGHT Kg
		kW	HP		A mm	B mm	C mm	
QDRM/02	1 x 230 V \pm 10 %	0,25	0,33	1 \div 1,6	280	220	160	2,2
QDRM/03	1 x 230 V \pm 10 %	0,37	0,5	1,6 \div 2,5	280	220	160	2,2
QDRM/05	1 x 230 V \pm 10 %	0,55	0,75	2,5 \div 4	280	220	160	2,2
QDRM/07	1 x 230 V \pm 10 %	0,75	1	4 \div 6,3	280	220	160	2,2
QDRM/15	1 x 230 V \pm 10 %	1,1 \div 1,5	1,5 \div 2	6,3 \div 10	280	220	160	2,2
QDRM/22	1 x 230 V \pm 10 %	2,2	3	10 \div 16	280	370	160	4,1

CB-QDRM-en_c_te

Electrical panel for drainage pumps

QDRMC Series single-phase



APPLICATIONS

- Protection and control of one single-phase drainage pump with external capacitor.

SPECIFICATIONS

- Automatic control through electromechanical floats.
- Power supply voltage: 1 x 230 V \pm 10%.
- Frequency: 50/60 Hz.
- Power: 0,75 to 2,2 kW.
- Direct motor start.
- Protection class: IP55.
- Ambient temperature: -5 to +40 °C (according to EN 60439-1).
- Maximum relative humidity: 50% at +40°C, provided that no condensation occurs (according to EN 60439-1).
- Wall mounted.
- Plastic enclosure.
- Electronic control module with test and alarm reset buttons, and power-on, pump running, high level alarm, thermal probe (versions /TS and /WD) and water in oil chamber (version /WD) indicator LED's.
- Alarm silencing button.
- Start and run capacitor incorporated in the control panel.
- /TS version equipped with stator thermal protection circuit.
- /WD version equipped with oil chamber water sensor control circuit and stator thermal protection.
- /TS/GL versions for electropumps GLS/GLV series.

OPTIONAL ACCESSORIES

- Audible or visual signalling device, 12 Vdc 0,3 A max (two connection terminals provided inside the electrical panel) for high-level alarm.
- VR1 single-phase module (for QDRM) for overvoltage protection (lightning protector).

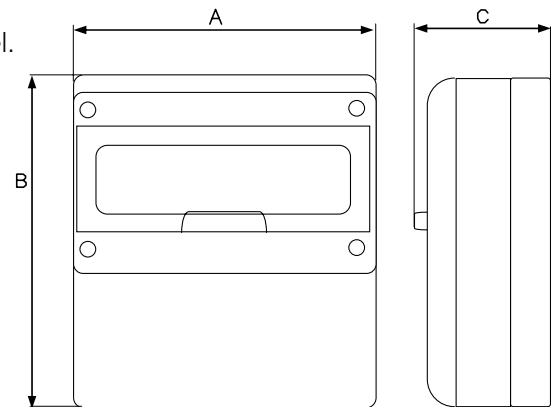

MODEL	RATED VOLTAGE V	RATED POWER		RATED CURRENT A	DIMENSIONS			WEIGHT Kg	C uF	Cs uF
		kW	HP		A mm	B mm	C mm			
QDRMC/07	1 x 230 V \pm 10 %	0,75	1	4 \div 6,3	280	370	160	3,1	20	40
QDRMC/15	1 x 230 V \pm 10 %	1,5	2	6,3 \div 10	280	370	160	3,1	35	60
QDRMC/22	1 x 230 V \pm 10 %	2,2	3	10 \div 16	280	370	160	3,1	35	60
QDRMC/07/TS	1 x 230 V \pm 10 %	0,75	1	4 \div 6,3	280	370	160	3,5	20	40
QDRMC/15/TS	1 x 230 V \pm 10 %	1,5	2	6,3 \div 10	280	370	160	3,5	35	60
QDRMC/22/TS	1 x 230 V \pm 10 %	2,2	3	10 \div 16	280	370	160	3,5	35	60
QDRMC/07/WD	1 x 230 V \pm 10 %	0,75	1	4 \div 6,3	280	370	160	4	20	40
QDRMC/15/WD	1 x 230 V \pm 10 %	1,5	2	6,3 \div 10	280	370	160	4	35	60
QDRMC/22/WD	1 x 230 V \pm 10 %	2,2	3	10 \div 16	280	370	160	4	35	60
QDRMC/15/TS/GL	1 x 230 V \pm 10 %	1,5	2	6,3 \div 10	280	370	160	4	35	100

C= Run capacitor; Cs= Start capacitor

CB-QDRMC-en_e_te

Electrical panel for drainage pumps

QDR Series three-phase



APPLICATIONS

- Protection and control of one three-phase drainage pump.

SPECIFICATIONS

- Automatic control through electromechanical floats.
- Power supply voltage: 3 x 400 V \pm 10%.
- Frequency: 50/60 Hz.
- Power: 0,37 to 9,2 kW.
- Direct motor start.
- Protection class: IP55.
- Ambient temperature: -5 to +40 °C (according to EN 60439-1).
- Maximum relative humidity: 50% at +40°C, provided that no condensation occurs (according to EN 60439-1).
- Wall mounted.
- Plastic enclosure.
- Power, thermal overload, high level indicator lights.
- Alarm silencing button.
- /TS version equipped with stator thermal protection circuit.
- /WD version equipped with oil chamber water sensor control circuit and stator thermal protection.

OPTIONAL ACCESSORIES

- Audible or visual signalling device, 12 Vdc 0,3 A max (two connection terminals provided inside the electrical panel) for high-level alarm.
- VR3 three-phase module (for QDR) for overvoltage protection (lightning protector).

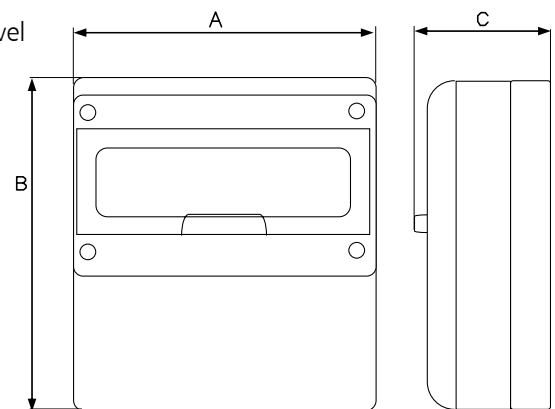

MODEL	RATED VOLTAGE V	RATED POWER		RATED CURRENT A	DIMENSIONS			WEIGHT Kg
		kW	HP		A mm	B mm	C mm	
QDR/03	3 x 400 V \pm 10 %	0,37	0,5	0,63 ÷ 1	280	370	150	4,1
QDR/05	3 x 400 V \pm 10 %	0,55	0,75	1 ÷ 1,6	280	370	150	4,1
QDR/07	3 x 400 V \pm 10 %	0,75	1	1,6 ÷ 2,5	280	370	150	4,1
QDR/15	3 x 400 V \pm 10 %	1,1 ÷ 1,5	1,5 ÷ 2	2,5 ÷ 4	280	370	150	4,1
QDR/22	3 x 400 V \pm 10 %	2,2	3	4 ÷ 6,3	280	370	150	4,1
QDR/40	3 x 400 V \pm 10 %	3 ÷ 4	4 ÷ 5,5	6,3 ÷ 10	280	370	150	4,1
QDR/75	3 x 400 V \pm 10 %	5,5 ÷ 7,5	7,5 ÷ 10	10 ÷ 16	280	370	150	4,1
QDR/07/TS	3 x 400 V \pm 10 %	0,75	1	1,6 ÷ 2,5	280	370	150	4,5
QDR/15/TS	3 x 400 V \pm 10 %	1,5	2	2,5 ÷ 4	280	370	150	4,5
QDR/22/TS	3 x 400 V \pm 10 %	2,2	3	4 ÷ 6,3	280	370	150	4,5
QDR/07/WD	3 x 400 V \pm 10 %	0,75	1	1,6 ÷ 2,5	280	370	150	5
QDR/15/WD	3 x 400 V \pm 10 %	1,5	2	2,5 ÷ 4	280	370	150	5
QDR/22/WD	3 x 400 V \pm 10 %	2,2	3	4 ÷ 6,3	280	370	150	5

The /WD option also includes the /TS option.

CB-QDR-en_c_te

Electrical panel for drainage pumps

QGMC Series



APPLICATIONS

- Protection and control of one single-phase drainage pump with external capacitor.

SPECIFICATIONS

- Automatic control via external contact.
- Supply voltage: 1 x 230 V \pm 10%.
- Frequency: 50 Hz.
- Power: 0,75 to 2,2 kW.
- Direct motor start.
- Protection class: IP55.
- Ambient temperature: -5 to +40 °C (according to EN 60439-1).
- Maximum relative humidity: 50% at +40°C, provided that no condensation occurs (according to EN 60439-1).
- Wall mounted.
- Plastic enclosure.
- Run capacitor.
- Start capacitor.
- Starter.
- Main switch with thermal protection.

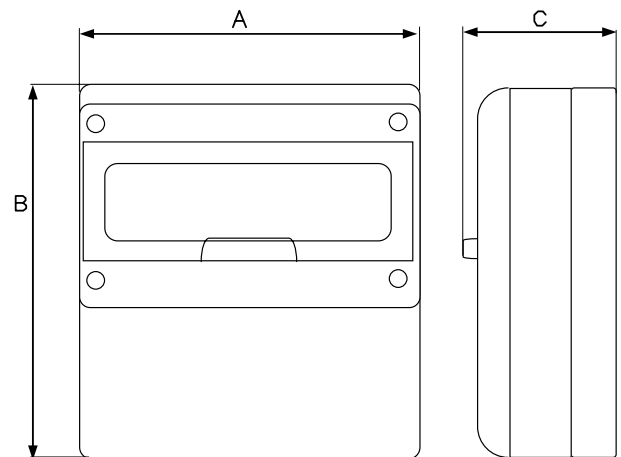

MODEL	RATED VOLTAGE V	RATED POWER		RATED CURRENT A	DIMENSIONS			WEIGHT Kg	C uF	Cs uF
		kW	HP		A mm	B mm	C mm			
QGMC/07	1 x 230 V \pm 10 %	0,75	1	4 \div 6,3	280	370	160	3	20	40
QGMC/15	1 x 230 V \pm 10 %	1,5	2	6,3 \div 10	280	370	160	3	35	60
QGMC/22	1 x 230 V \pm 10 %	2,2	3	10 \div 16	280	370	160	3	35	60

C = Run capacitor; Cs = Start capacitor.

CB-QGMC-en_a_te

Electrical panel for drainage pumps

QDRM2 Series single-phase



APPLICATIONS

- Protection and control of two single-phase drainage pumps.

SPECIFICATIONS

- Automatic control through electromechanical floats.
- Power supply voltage: 1 x 230 V \pm 10%.
- Frequency: 50/60 Hz.
- Power: 0,25 to 2,2 kW.
- Direct motor start.
- Protection class: IP54.
- Ambient temperature: -5 to +40 °C (according to EN 60439-1).
- Maximum relative humidity: 50% at +40°C, provided that no condensation occurs (according to EN 60439-1).
- Wall mounted.
- Metal enclosure.
- Electronic board with power, thermal overload, high level alarm, pump start/stop indicator LEDs.
- Alarm silencing button.

OPTIONAL ACCESSORIES

- Audible or visual signalling device, 12 Vdc 0,3 A max (two connection terminals provided inside the electrical panel) for high-level alarm.
 - VR1 single-phase module for overvoltage protection (lightning protector).
 - Signal relay board kit (power, auto/man, start/stop, thermal overload, high level).

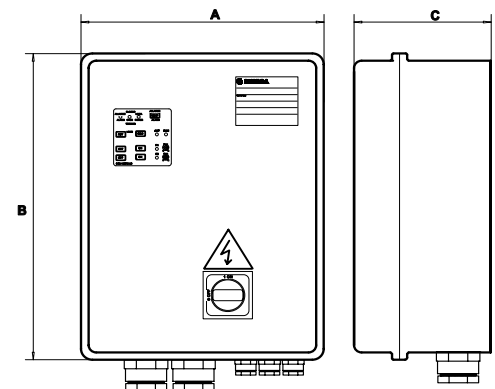

MODEL	RATED VOLTAGE V	RATED POWER		RATED CURRENT A	DIMENSIONS			WEIGHT Kg
		kW	HP		A mm	B mm	C mm	
QDRM2/02	1 x 230 V \pm 10 %	0,25	0,33	1 \div 1,6	260	380	150	9,4
QDRM2/03	1 x 230 V \pm 10 %	0,37	0,5	1,6 \div 2,5	260	380	150	9,4
QDRM2/05	1 x 230 V \pm 10 %	0,55	0,75	2,5 \div 4	260	380	150	9,4
QDRM2/07	1 x 230 V \pm 10 %	0,75	1	4 \div 6,3	260	380	150	9,4
QDRM2/15	1 x 230 V \pm 10 %	1,1 \div 1,5	1,5 \div 2	6,3 \div 10	260	380	150	9,4
QDRM2/22	1 x 230 V \pm 10 %	2,2	3	10 \div 16	260	380	150	9,4

CB-QDRM2-en_a_te

Electrical panel for drainage pumps

QYR Series three-phase



APPLICATIONS

- Protection and control of one three-phase drainage pump with star-delta start.

SPECIFICATIONS

- Automatic control through electromechanical floats.
- Power supply voltage: 3 x 400 V \pm 10%.
- Frequency: 50/60 Hz.
- Power: 3 to 75 kW.
- Star-delta motor start.
- Protection class: IP54.
- Ambient temperature: -5 to +40 °C (according to EN 60439-1).
- Maximum relative humidity: 50% at +40°C, provided that no condensation occurs (according to EN 60439-1).
- Wall mounted.
- Metal enclosure.
- Electronic board with power, thermal overload, high level alarm, pump start/stop indicator LEDs.
- Alarm silencing button.
- /TS version equipped with stator thermal protection circuit.
- /WD version equipped with oil chamber water sensor control circuit and stator thermal protection.

OPTIONAL ACCESSORIES

- Audible or visual signalling device, 12 Vdc 0,3 A max (two connection terminals provided inside the electrical panel) for high-level alarm.
 - VR3 three-phase module (for QDR) for overvoltage protection (lightning protector).
 - Signal relay board kit (power, auto/man, start/stop, thermal overload, high level).

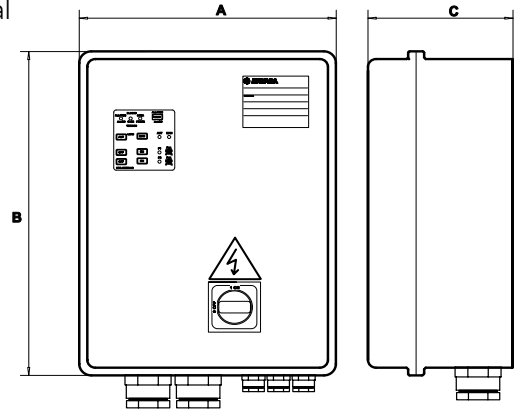

QYR SERIES PANELS ELECTRICAL DATA TABLE

MODEL	RATED VOLTAGE V	RATED POWER		RATED CURRENT A	DIMENSIONS			WEIGHT Kg
		kW	HP		A mm	B mm	C mm	
QYR/40	3 x 400 V ± 10 %	3 ÷ 4	4 ÷ 5,5	6,3 ÷ 10	400	500	200	25
QYR/75	3 x 400 V ± 10 %	5,5 ÷ 7,5	7,5 ÷ 10	10 ÷ 16	400	500	200	25
QYR/92	3 x 400 V ± 10 %	9,2	12,5	16 ÷ 20	400	500	200	25
QYR/110	3 x 400 V ± 10 %	11	15	20 ÷ 25	400	500	200	25
QYR/150	3 x 400 V ± 10 %	15	20	22 ÷ 32	400	600	200	27
QYR/185	3 x 400 V ± 10 %	18,5	25	28 ÷ 40	400	600	200	27
QYR/220	3 x 400 V ± 10 %	22	30	36 ÷ 50	500	700	200	32
QYR/300	3 x 400 V ± 10 %	30	40	45 ÷ 63	500	700	200	32
QYR/370	3 x 400 V ± 10 %	37	50	57 ÷ 75	600	800	250	32
QYR/450	3 x 400 V ± 10 %	45	60	70 ÷ 90	600	800	250	32
QYR/550	3 x 400 V ± 10 %	55	75	80 ÷ 108	600	900	250	37
QYR/750	3 x 400 V ± 10 %	75	100	105 ÷ 138	600p	1300p	300p	70
QYR/22/TS	3 x 400 V ± 10 %	2,2	3	4 ÷ 6,3	400	500	200	25
QYR/40/TS	3 x 400 V ± 10 %	3 ÷ 4	4 ÷ 5,5	6,3 ÷ 10	400	500	200	26
QYR/75/TS	3 x 400 V ± 10 %	5,5 ÷ 7,5	7,5 ÷ 10	10 ÷ 16	400	500	200	26
QYR/92/TS	3 x 400 V ± 10 %	9,2	12,5	16 ÷ 20	400	500	200	26
QYR/110/TS	3 x 400 V ± 10 %	11	15	20 ÷ 25	400	500	200	26
QYR/150/TS	3 x 400 V ± 10 %	15	20	22 ÷ 32	400	600	200	27
QYR/185/TS	3 x 400 V ± 10 %	18,5	25	28 ÷ 40	400	600	200	27
QYR/220/TS	3 x 400 V ± 10 %	22	30	36 ÷ 50	500	700	200	32
QYR/300/TS	3 x 400 V ± 10 %	30	40	45 ÷ 63	500	700	200	32
QYR/370/TS	3 x 400 V ± 10 %	37	50	57 ÷ 75	600	800	250	33
QYR/450/TS	3 x 400 V ± 10 %	45	60	70 ÷ 90	600	800	250	33
QYR/550/TS	3 x 400 V ± 10 %	55	75	80 ÷ 108	600	900	250	37
QYR/750/TS	3 x 400 V ± 10 %	75	100	105 ÷ 138	600p	1300p	300p	70
QYR/40/WD	3 x 400 V ± 10 %	3 ÷ 4	4 ÷ 5,5	6,3 ÷ 10	400	500	200	26
QYR/75/WD	3 x 400 V ± 10 %	5,5 ÷ 7,5	7,5 ÷ 10	10 ÷ 16	400	500	200	26
QYR/92/WD	3 x 400 V ± 10 %	9,2	12,5	16 ÷ 20	400	500	200	26
QYR/110/WD	3 x 400 V ± 10 %	11	15	20 ÷ 25	400	500	200	26
QYR/150/WD	3 x 400 V ± 10 %	15	20	22 ÷ 32	400	600	200	28
QYR/185/WD	3 x 400 V ± 10 %	18,5	25	28 ÷ 40	400	600	200	28
QYR/220/WD	3 x 400 V ± 10 %	22	30	36 ÷ 50	500	700	200	33
QYR/300/WD	3 x 400 V ± 10 %	30	40	45 ÷ 63	500	700	200	33
QYR/370/WD	3 x 400 V ± 10 %	37	50	57 ÷ 75	600	800	250	33
QYR/450/WD	3 x 400 V ± 10 %	45	60	70 ÷ 90	600	800	250	33
QYR/550/WD	3 x 400 V ± 10 %	55	75	80 ÷ 108	600	900	250	38
QYR/750/WD	3 x 400 V ± 10 %	75	100	105 ÷ 138	600p	1300p	300p	71

Dimensions: p = floor-standing cabinet.

CB-QYR-en_e_te

Electrical panel for drainage pumps

QDRMC2 Series single-phase



APPLICATIONS

- Protection and control of two single-phase drainage pumps with external capacitor.

SPECIFICATIONS

- Automatic control through electromechanical floats.
- Power supply voltage: 1 x 230 V \pm 10%.
- Frequency: 50/60 Hz.
- Power: 0,75 to 2,2 kW.
- Direct motor start.
- Protection class: IP54.
- Ambient temperature: -5 to +40 °C (according to EN 60439-1).
- Maximum relative humidity: 50% at +40°C, provided that no condensation occurs (according to EN 60439-1).
- Wall mounted.
- Plastic enclosure.
- Electronic board with power, thermal overload, high level alarm, pump start/stop indicator LEDs.
- Start and run capacitor incorporated in the control panel.
- /TS version equipped with stator thermal protection circuit.
- /WD version equipped with oil chamber water sensor control circuit and stator thermal protection.
- /TS/GL versions for electropumps GLS/GLV series.

OPTIONAL ACCESSORIES

- Audible or visual signalling device, 12 Vdc 0,3 A max (two connection terminals provided inside the electrical panel) for high-level alarm.
 - VR1 single-phase module for overvoltage protection (lightning protector).
 - Signal relay board kit (power, auto/man, start/stop, thermal overload, high level).

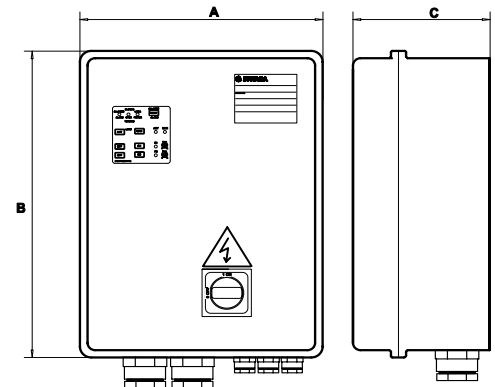

MODEL	RATED VOLTAGE V	RATED POWER		RATED CURRENT A	DIMENSIONS			WEIGHT Kg	C uF	Cs uF
		kW	HP		A mm	B mm	C mm			
QDRMC2/07	1 x 230 V \pm 10 %	0,75	1	4 ÷ 6,3	390	470	130	8,5	20	40
QDRMC2/15	1 x 230 V \pm 10 %	1,5	2	6,3 ÷ 10	390	470	130	8,5	35	60
QDRMC2/22	1 x 230 V \pm 10 %	2,2	3	10 ÷ 16	390	470	130	8,5	35	60
QDRMC2/07/TS	1 x 230 V \pm 10 %	0,75	1	4 ÷ 6,3	390	470	130	9	20	40
QDRMC2/15/TS	1 x 230 V \pm 10 %	1,5	2	6,3 ÷ 10	390	470	130	9	35	60
QDRMC2/22/TS	1 x 230 V \pm 10 %	2,2	3	10 ÷ 16	390	470	130	9	35	60
QDRMC2/07/WD	1 x 230 V \pm 10 %	0,75	1	4 ÷ 6,3	390	470	130	10	20	40
QDRMC2/15/WD	1 x 230 V \pm 10 %	1,5	2	6,3 ÷ 10	390	470	130	10	35	60
QDRMC2/22/WD	1 x 230 V \pm 10 %	2,2	3	10 ÷ 16	390	470	130	10	35	60
QDRMC2/15/TS/GL	1 x 230 V \pm 10 %	1,5	2	6,3 ÷ 10	390	470	130	10	35	100

C = Run capacitor; Cs = Start capacitor.

CB-QDRMC2-en_d_te

Electrical panel for drainage pumps

QDR2 Series three-phase



APPLICATIONS

- Protection and control of two three-phase drainage pumps.

SPECIFICATIONS

- Automatic control through electromechanical floats.
- Power supply voltage: 3 x 400 V \pm 10%.
- Frequency: 50/60 Hz.
- Power: 0,37 to 9,2 kW.
- Direct motor start.
- Protection class: IP54.
- Ambient temperature: -5 to +40 °C (according to EN 60439-1).
- Maximum relative humidity: 50% at +40°C, provided that no condensation occurs (according to EN 60439-1).
- Wall mounted.
- Metal enclosure.
- Electronic board with power, thermal overload, high level alarm, pump start/stop indicator LEDs.
- Alarm silencing button.
- /TS version equipped with stator thermal protection circuit.
- /WD version equipped with oil chamber water sensor control circuit and stator thermal protection.

OPTIONAL ACCESSORIES

- Audible or visual signalling device, 12 Vdc 0,3 A max (two connection terminals provided inside the electrical panel) for high-level alarm.
 - VR3 three-phase module for overvoltage protection (lightning protector).
 - Signal relay board kit (power, auto/man, start/stop, thermal overload, high level).

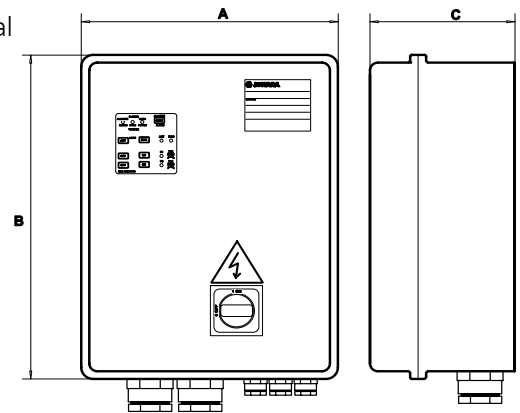

MODEL	RATED VOLTAGE V	RATED POWER		RATED CURRENT A	DIMENSIONS			WEIGHT Kg
		kW	HP		A mm	B mm	C mm	
QDR2/03	3 x 400 V \pm 10 %	0,37	0,5	0,63 ÷ 1	260	380	150	9,4
QDR2/05	3 x 400 V \pm 10 %	0,55	0,75	1 ÷ 1,6	260	380	150	9,4
QDR2/07	3 x 400 V \pm 10 %	0,75	1	1,6 ÷ 2,5	260	380	150	9,4
QDR2/15	3 x 400 V \pm 10 %	1,1 ÷ 1,5	1,5 ÷ 2	2,5 ÷ 4	260	380	150	9,4
QDR2/22	3 x 400 V \pm 10 %	2,2	3	4 ÷ 6,3	260	380	150	9,4
QDR2/40	3 x 400 V \pm 10 %	3 ÷ 4	4 ÷ 5,5	6,3 ÷ 10	260	380	150	9,4
QDR2/75	3 x 400 V \pm 10 %	5,5 ÷ 7,5	7,5 ÷ 10	10 ÷ 16	260	380	150	9,4
QDR2/92	3 x 400 V \pm 10 %	9,2	12,5	16 ÷ 20	300	400	180	11
QDR2/07/TS	3 x 400 V \pm 10 %	0,75	1	1,6 ÷ 2,5	400	400	200	14
QDR2/15/TS	3 x 400 V \pm 10 %	1,1 ÷ 1,5	1,5 ÷ 2	2,5 ÷ 4	400	400	200	14
QDR2/22/TS	3 x 400 V \pm 10 %	2,2	3	4 ÷ 6,3	400	400	200	14
QDR2/07/WD	3 x 400 V \pm 10 %	0,75	1	1,6 ÷ 2,5	400	500	200	18
QDR2/15/WD	3 x 400 V \pm 10 %	1,1 ÷ 1,5	1,5 ÷ 2	2,5 ÷ 4	400	500	200	18
QDR2/22/WD	3 x 400 V \pm 10 %	2,2	3	4 ÷ 6,3	400	500	200	18

The /WD option also includes the /TS option.

CB-QDR2-en_b_te

Electrical panel for drainage pumps

QYR2 Series three-phase



APPLICATIONS

- Protection and control of two three-phase drainage pumps with star-delta start.

SPECIFICATIONS

- Automatic control through electromechanical floats.
- Power supply voltage: 3 x 400 V \pm 10%.
- Frequency: 50/60 Hz.
- Power: 3 to 75 kW.
- Star-delta motor start.
- Protection class: IP54.
- Ambient temperature: -5 to +40 °C (according to EN 60439-1).
- Maximum relative humidity: 50% at +40°C, provided that no condensation occurs (according to EN 60439-1).
- Wall mounted.
- Metal enclosure.
- Electronic board with power, thermal overload, high level alarm, pump start/stop indicator LEDs.
- Alarm silencing button.
- /TS version equipped with stator thermal protection circuit.
- /WD version equipped with oil chamber water sensor control circuit and stator thermal protection.

OPTIONAL ACCESSORIES

- Audible or visual signalling device, 12 Vdc 0,3 A max (two connection terminals provided inside the electrical panel) for high-level alarm.
 - VR3 three-phase module for overvoltage protection (lightning protector).
 - Signal relay board kit (power, auto/man, start/stop, thermal overload, high level).

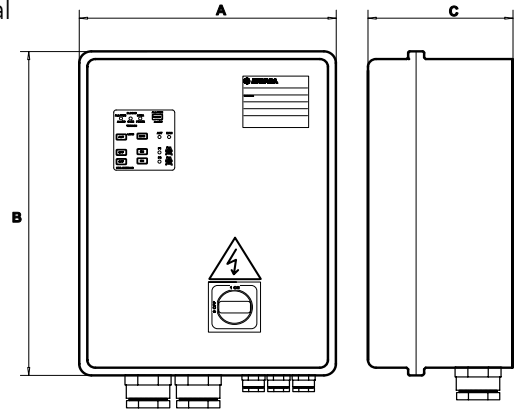

QYR2 SERIES PANELS ELECTRIC DATA TABLE

MODEL	RATED VOLTAGE V	RATED POWER		RATED CURRENT A	DIMENSIONS			WEIGHT Kg
		kW	HP		A mm	B mm	C mm	
QYR2/40	3 x 400 V ± 10 %	3 ÷ 4	4 ÷ 5,5	6,3 ÷ 10	500	700	200	55
QYR2/75	3 x 400 V ± 10 %	5,5 ÷ 7,5	7,5 ÷ 10	10 ÷ 16	500	700	200	55
QYR2/92	3 x 400 V ± 10 %	9,2	12,5	16 ÷ 20	500	700	200	55
QYR2/110	3 x 400 V ± 10 %	11	15	20 ÷ 25	500	700	200	55
QYR2/150	3 x 400 V ± 10 %	15	20	22 ÷ 32	600	800	250	68
QYR2/185	3 x 400 V ± 10 %	18,5	25	28 ÷ 40	600	800	250	68
QYR2/220	3 x 400 V ± 10 %	22	30	36 ÷ 50	600	900	250	75
QYR2/300	3 x 400 V ± 10 %	30	40	45 ÷ 63	600	900	250	75
QYR2/370	3 x 400 V ± 10 %	37	50	57 ÷ 75	600p	1300p	300p	92
QYR2/450	3 x 400 V ± 10 %	45	60	70 ÷ 90	800p	1700p	300p	125
QYR2/550	3 x 400 V ± 10 %	55	75	80 ÷ 108	800p	1700p	300p	125
QYR2/750	3 x 400 V ± 10 %	75	100	105 ÷ 138	800p	1900p	300p	148
QYR2/22/TS	3 x 400 V ± 10 %	2,2	3	4 ÷ 6,3	500	700	200	55
QYR2/40/TS	3 x 400 V ± 10 %	3 ÷ 4	4 ÷ 5,5	6,3 ÷ 10	500	700	200	55
QYR2/75/TS	3 x 400 V ± 10 %	5,5 ÷ 7,5	7,5 ÷ 10	10 ÷ 16	500	700	200	55
QYR2/92/TS	3 x 400 V ± 10 %	9,2	12,5	16 ÷ 20	500	700	200	55
QYR2/110/TS	3 x 400 V ± 10 %	11	15	20 ÷ 25	500	700	200	55
QYR2/150/TS	3 x 400 V ± 10 %	15	20	22 ÷ 32	600	800	250	68
QYR2/185/TS	3 x 400 V ± 10 %	18,5	25	28 ÷ 40	600	800	250	68
QYR2/220/TS	3 x 400 V ± 10 %	22	30	36 ÷ 50	600	900	250	75
QYR2/300/TS	3 x 400 V ± 10 %	30	40	45 ÷ 63	600	900	250	75
QYR2/370/TS	3 x 400 V ± 10 %	37	50	57 ÷ 75	600p	1300p	300p	92
QYR2/450/TS	3 x 400 V ± 10 %	45	60	70 ÷ 90	800p	1700p	300p	125
QYR2/550/TS	3 x 400 V ± 10 %	55	75	80 ÷ 108	800p	1700p	300p	125
QYR2/750/TS	3 x 400 V ± 10 %	75	100	105 ÷ 138	800p	1900p	300p	148
QYR2/40/WD	3 x 400 V ± 10 %	3 ÷ 4	4 ÷ 5,5	6,3 ÷ 10	500	700	200	55
QYR2/75/WD	3 x 400 V ± 10 %	5,5 ÷ 7,5	7,5 ÷ 10	10 ÷ 16	500	700	200	55
QYR2/92/WD	3 x 400 V ± 10 %	9,2	12,5	16 ÷ 20	500	700	200	55
QYR2/110/WD	3 x 400 V ± 10 %	11	15	20 ÷ 25	500	700	200	55
QYR2/150/WD	3 x 400 V ± 10 %	15	20	22 ÷ 32	600	800	250	68
QYR2/185/WD	3 x 400 V ± 10 %	18,5	25	28 ÷ 40	600	800	250	68
QYR2/220/WD	3 x 400 V ± 10 %	22	30	36 ÷ 50	600	900	250	75
QYR2/300/WD	3 x 400 V ± 10 %	30	40	45 ÷ 63	600	900	250	75
QYR2/370/WD	3 x 400 V ± 10 %	37	50	57 ÷ 75	600p	1300p	300p	92
QYR2/450/WD	3 x 400 V ± 10 %	45	60	70 ÷ 90	800p	1700p	300p	125
QYR2/550/WD	3 x 400 V ± 10 %	55	75	80 ÷ 108	800p	1700p	300p	125
QYR2/750/WD	3 x 400 V ± 10 %	75	100	105 ÷ 138	800p	1900p	300p	148

Dimensions: p = floor-standing cabinet.

CB-QYR2-en_b_te

Electrical panel for drainage pumps

QXR20 Series single-phase



APPLICATIONS

- Protection and control of two single-phase drainage pumps.

SPECIFICATIONS

- Automatic control through electromechanical floats.
- Power supply voltage: 1 x 230 V \pm 10%.
- Frequency: 50/60 Hz.
- Power: 0,25 to 1,5 kW.
- Direct motor start.
- Protection class: IP55.
- Ambient temperature: -5 to +40 °C (according to EN 60439-1).
- Maximum relative humidity: 50% at +40°C, provided that no condensation occurs (according to EN 60439-1).
- Wall mounted.
- Plastic enclosure.
- Electronic board with power, thermal overload, acoustic alarm of high level, pump, start/stop indicator LEDs.
- Alarm silencing button.
- Cyclic exchange starting pumps.
- Aut-0-Man selector (1 for each pump).
- One pump is controlled by the closing of internal contact that is inside the control card.

OPTIONAL ACCESSORIES

- Signal relay board kit (power, auto man, start/stop, thermal overload, high level).

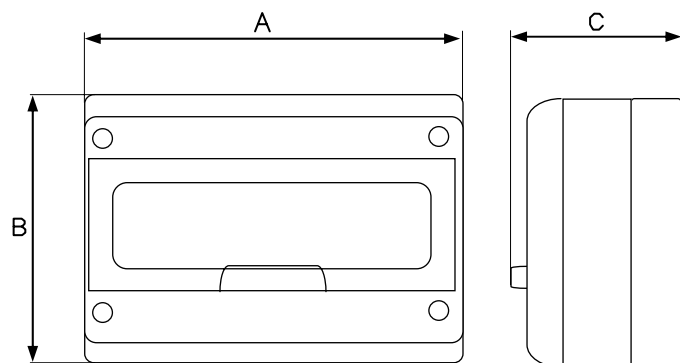

MODEL	RATED VOLTAGE V	RATED POWER		RATED CURRENT A	DIMENSIONS			WEIGHT Kg
		kW	HP		A mm	B mm	C mm	
QXR20	1 x 230 V \pm 10 %	0,25 ÷ 1,5	0,33 ÷ 2	1 ÷ 10	205	220	160	1,5

CB-QXR20-en_a_te

Level Control Panel

APPLICATIONS

- Accessory for electric pump control panels, suitable for tank filling or drainage applications or for activation of audible or visual alarms.

QCL5 Series



SPECIFICATIONS

- Automatic control through probes.
- Supply voltage:
1 x 230 V \pm 10% or 1 x 24 V \pm 10%.
- Frequency: 50/60 Hz.
- Voltage to probes:
15 V AC at 0,5 mA max.
- Switch contact 48 V AC at 3 A max (250 W max).
- Protection class: IP55.
- Ambient temperature: -5 to +40 °C (according to EN 60439-1).
- Maximum relative humidity: 50% at +40°C, provided that no condensation occurs (according to EN 60439-1).
- Wall mounted.
- Plastic enclosure.
- Electrodes suitable for water at a maximum temperature of 40°C.
- Set of three electrodes included in the supply.

OPTIONAL ACCESSORIES

- Drop cable with circular cross section.

For connection of the electrodes to the panel we recommend the following cross sections:

LENGHT m		CABLE SECTION mm ²
0	50	0,5
50	100	0,75
100	200	1,0
200	400	2,5

CB-CASEL-en_b_te

Three-pole cables can be used for short lengths.

Otherwise we recommend the use of unipolar cables placed at suitable distance from each other to prevent the capacitive effect of the cable from interfering with the proper operation of the electronic module.

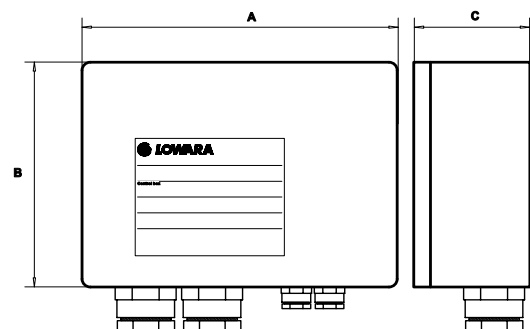

TYPE	POWER SUPPLY			CONTACT			DIMENSIONS A x B x C mm	WEIGHT Kg
	VOLTAGE V	FREQUENCY Hz	POWER W	TYPE	RANGE V	A		
QCL5/24	1 x 24	50/60	2	NO-C-NC	48	3	90 x 130 x 60	0,5
QCL5/230	1 x 230	50/60	2					

CB-QCL5-en_a_te

Level Control Panel

APPLICATIONS

- Accessory for electric pump control panels, suitable for tank filling or drainage applications or for activation of audible or visual alarms.

QCL10 Series



SPECIFICATIONS

- Automatic control through probes.
- Supply voltage: 1 x 230 V \pm 10% or 1 x 24 V \pm 10%.
- Frequency: 50/60 Hz.
- Voltage to probes: 7,5 V AC at 0,4 mA max.
- Protection class: IP55.
- Ambient temperature: -5 to +40 °C (according to EN 60439-1).
- Maximum relative humidity: 50% at +40°C, provided that no condensation occurs (according to EN 60439-1).
- Wall mounted.
- Plastic enclosure.
- Electrodes suitable for water at a maximum temperature of 60°C.
- Set of three electrodes included in the supply.

OPTIONAL ACCESSORIES

- Drop cable with circular cross section.

For connection of the electrodes to the panel we recommend the following cross sections:

LENGHT m		CABLE SECTION mm ²
0	50	0,5
50	100	0,75
100	200	1,0
200	400	2,5

CB-CASEL-en_b_te

Three-pole cables can be used for short lengths.

Otherwise we recommend the use of unipolar cables placed at suitable distance from each other to prevent the capacitive effect of the cable from interfering with the proper operation of the electronic module.

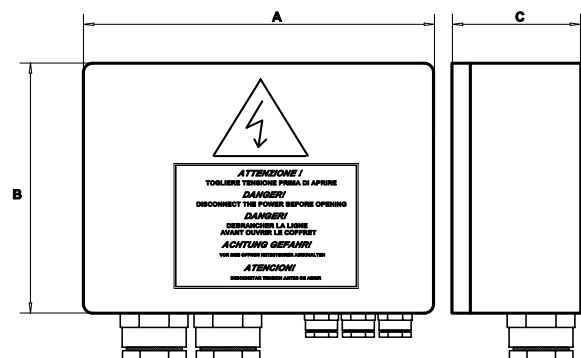

TYPE	POWER SUPPLY		CONTACTOR			DIMENSIONS A x B x C mm	WEIGHT Kg
	MAIN V	SECONDARY V	CLASS	RANGE V A			
QCL10/24	1x230	50/60 Hz	AC3	230	9	170 x 170 x 130	1
QCL10/230	1x230	50/60 Hz					

CB-QCL10-en_a_te

Level Control Panel

APPLICATIONS

- Accessory for electric pump control panels, suitable for tank filling or drainage applications or for activation of audible or visual alarms

QCLP10 Series



SPECIFICATIONS

- Automatic control through probes.
- Supply voltage: 1 x 230 V \pm 10% or 1 x 24 V \pm 10%.
- Frequency: 50/60 Hz.
- Voltage to probes: 7,5 V AC at 0,4 mA max.
- Protection class: IP55.
- Ambient temperature: -5 to +40 °C (according to EN 60439-1).
- Maximum relative humidity: 50% at +40°C, provided that no condensation occurs (according to EN 60439-1).
- Wall mounted.
- Enclosure made of plastic material, with clear door enabling access to the magnetothermal switch.
- Electrodes suitable for water at a maximum temperature of 60°C.
- Set of three electrodes included in the supply.

OPTIONAL ACCESSORIES

- Drop cable with circular cross section.

For connection of the electrodes to the panel we recommend the following cross sections:

LENGHT m		CABLE SECTION mm ²
0	50	0,5
50	100	0,75
100	200	1,0
200	400	2,5

CB-CASEL-en_b_te

Three-pole cables can be used for short lengths.

Otherwise we recommend the use of unipolar cables placed at suitable distance from each other to prevent the capacitive effect of the cable from interfering with the proper operation of the electronic module.

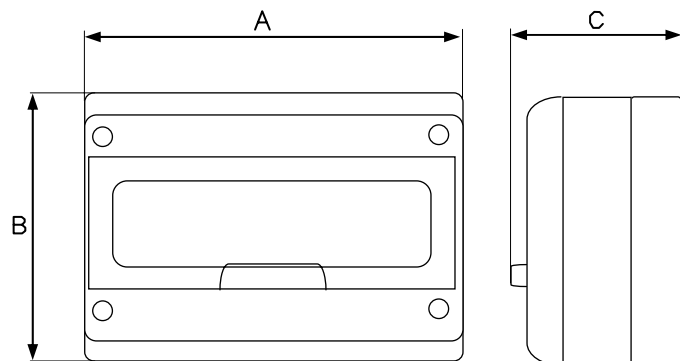

TYPE	POWER SUPPLY				CONTACTOR			MAGNETO-THERMAL SWITCH	DIMENSIONS A x B x C mm	WEIGHT Kg
	MAIN V		SECONDARY V		CLASS	RANGE V A				
QCLP10/24	1x230	50/60 Hz	1x 24	50/60 Hz	AC3	230	9	C 10A Icn 6 KA	205 x 220 x 160	1,5
QCLP10/230	1x230	50/60 Hz	-							

CB-QCLP10-en_b_te

Kit 24 V Level Probe

APPLICATIONS

- Accessory for electric panels.

KSL Series



SPECIFICATIONS

- Electronic module for use of probes as protection against dry running.
- Supply voltage:
1 x 24 V \pm 10% for model SLD/24.
- Frequency: 50/60 Hz.
- Absorbed power: 3,5 VA max.
- Voltage to probes:
7,5 V AC at 0,4 mA max.
- Switch contact 24 V AC at 5 A max (250 W max).
- Designed for installation on Lowara electric panels featuring DIN bar.
- Electrodes suitable for water at a maximum temperature of 60°C.

CONSTRUCTION CHARACTERISTICS

- Module made of plastic material with DIN bar attachment.
- Cables with quick plug-in connectors.
- Set of three electrodes included in the supply.
- Electrodes with nylon 6 body, stainless steel sensitive element brass washer and nitrile rubber seal.

OPTIONAL ACCESSORIES

- Drop cable with circular cross section.

For connection of the electrodes to the panel we recommend the following cross sections:

LENGHT m		CABLE SECTION mm ²
0	50	0,5
50	100	0,75
100	200	1,0
200	400	2,5

CB-CASEL-en_b_te

Three-pole cables can be used for short lengths.

Otherwise we recommend the use of unipolar cables placed at suitable distance from each other to prevent the capacitive effect of the cable from interfering with the proper operation of the electronic module.

TYPE	POWER SUPPLY		POWER VA	CONTACT			DIMENSIONS A x B x C mm	WEIGHT Kg	PANELS
	MAIN V			TYPE	RANGE V~	A			
KIT KSL/24	1x24	50/60 Hz	3,5	N0-C-NC	250	8	90 x 36 x 60	0,5	QSCS-QM-QTD-Q3D-Q3Y-Q3A-Q3I-Q3SF

CB-SLD-en_b_te

Lightning Protection

APPLICATIONS

- Accessory for electric panels.

DPF Series



SPECIFICATIONS

- Varistor for overvoltage protection of single-phase lines. To be connected between the phase and neutral conductor.
- Operating voltage: 460 V AC.
- Maximum varistor voltage: 750 V with 100 A peak current.

VR Series



SPECIFICATIONS

- Varistors for overvoltage protection of three-phase lines.
- To be connected between the phases (VR3 model).
- Operating voltage: 460 V AC.
- Maximum varistor voltage: 750 V with 100 A peak current.
- Designed for installation on Lowara electric panels featuring DIN bar.

SCA3 Series

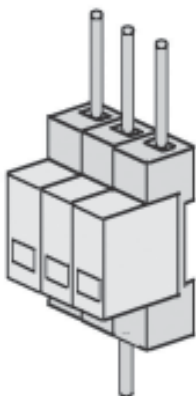

SPECIFICATIONS

- Lightning arresters for overvoltage protection of three-phase lines. To be connected between the phases and the heart conductor,
- Operating voltage: 500 V AC.
- Maximum varistor voltage: 2,5 kW with 40 kA peak current.
- Designed for installation on Lowara electric panels featuring DIN bar.

TYPE	VOLTAGE V	PANELS
DPF	1 x 220-240 50/60 Hz	QSM - QSC - QSCS - QPC
KIT VR1	1 x 220-230 50/60 Hz	QM - QDRM - QDRM2 - QDRMC - QDRMC2
KIT VR3	3 x 400 50/60 Hz	QTD - QDR - QDR2 - Q3D
KIT SCA 3	3 x 400 50/60 Hz	Q3Y-Q3A-Q3I-Q3SF-Q3D

Electronic board

APPLICATIONS

- Applicable to Lowara electronic boards series SM20C and SDR20B.

KIT RILS20 Series

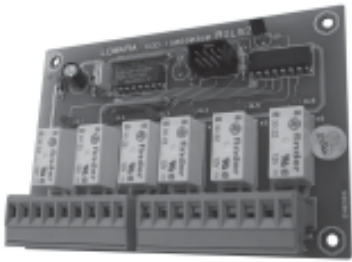

SPECIFICATIONS

- 12 Vdc power input from motherboard.
- Six low profile 12 Vdc relays with 1A 230 Vac exchange contact.
- Indicator LED's available for each relay.
- Available signals: power-on, manual/automatic mode, pump 1 running, pump 2 running, thermal overload, level alarm.
- Assembly: with board guides as well as 4 holes for flat-mounting on uprights.
- Customer-side output connections: removable clamp.
- Maximum dimensions: A=112 mm, B=80 mm, C=22 mm.

PRODUCT FEATURES

Complete electronic board providing clean system status contacts. Can be connected, via an 8-way serial cable with sealed plug, to boards SM20C, SDR20B (1000 mm long cable supplied). 1500 mm long cable available on request.

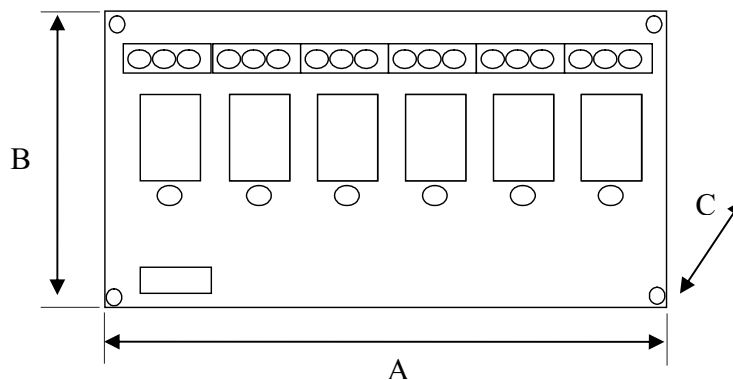

Xylem |'zīləm|

- 1) The tissue in plants that brings water upward from the roots;
- 2) a leading global water technology company.

We're 12,000 people unified in a common purpose: creating innovative solutions to meet our world's water needs. Developing new technologies that will improve the way water is used, conserved, and re-used in the future is central to our work. We move, treat, analyze, and return water to the environment, and we help people use water efficiently, in their homes, buildings, factories and farms. In more than 150 countries, we have strong, long-standing relationships with customers who know us for our powerful combination of leading product brands and applications expertise, backed by a legacy of innovation.

For more information on how Xylem can help you, go to xylem.com.



Headquarters

LOWARA S.r.l. Unipersonale

Via Lombardi 14

36075 Montecchio Maggiore - Vicenza - Italy

Tel. (+39) 0444 707111 - Fax (+39) 0444 492166

e-mail: lowara.mkt@xylem.com

web: www.lowara.com - www.completewatersystems.com

LOWARA reserves the right to make modification without prior notice.
LOWARA is a trademark of Xylem Inc. or one of its subsidiaries.