

1113-1114 BUTTERFLY VALVES + NA ELECTRIC ACTUATOR

CHARACTERISTICS

The 1113-1114 double eccentric butterfly valves are high performance valves dedicated to the automatic shut-off of high pressure and/or low temperature fluids like steam, bitumen, thermal oils, alkali, etc. The valve has an assembly direction but its tightness is bi-directional. The one-piece butterfly stem is mounted on bearings and offers an antistatic device. Its firesafe construction enables its use in the hydrocarbon sector. The ISO 5211 pad allows the mounting of standardized actuators.



AVAILABLE ITEMS

1113: carbon steel body

1114: stainless steel body

DN 50 to DN 300, face-to-face dimensions according to the ISO 5752 series 20 standard

Flanged connections EN 1092 RF PN 25

Voltages: 24 V AC/DC, 230 V AC, 3~400 V AC

LIMITS OF USE

Max. allowable pressure (PS)	25 bar
Min./max. allowable temperature (TS)	Steel: -25 °C / +210 °C Stainless steel: -30 °C / +210 °C
Room temperature	-20 °C / +70 °C
Service	S2 – 70%

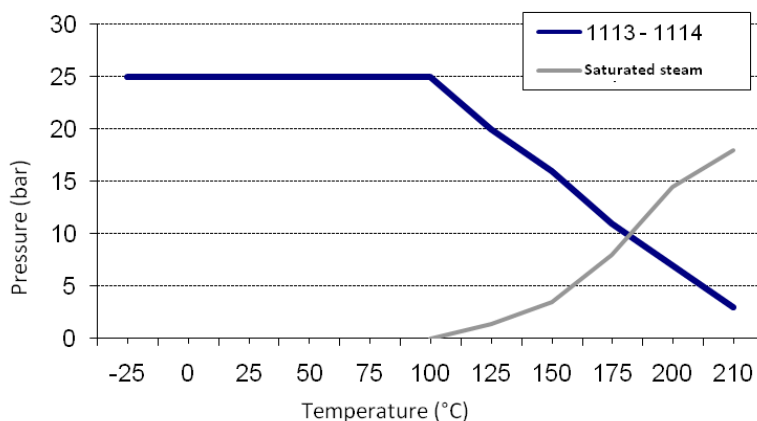

The following data is for information purpose only and may be subject to alteration without prior notice

	SECTORIEL S.A. 45, rue du Ruisseau 38290 Saint Quentin-Fallavier – FRANCE Tel.: +33 474 94 90 70 – Fax: +33 474 94 13 95 www.sectoriel.fr / email: sectoriel@sectoriel.fr	Nbr. pages	1/4
	Ref.	1113+NA GB	
	Rev.	4	
	Date	09/2011	

1113-1114 BUTTERFLY VALVES + NA ELECTRIC ACTUATOR

DIRECTIVES AND DEVELOPMENT STANDARDS APPLICABLE

	Standard
97/23/EC Pressure Equipment Directive	Cat.III Module H - CE 0035
ATEX Directive	EN 13463-1 : II 2G/D
Construction	API 609 and MSS SP-68
Body materials	EN 1503-2
Material certificate	EN 10204
Flanges dimension	EN 1092-1
Face-to-face dimension	ISO 5752 series 20
Valve leakage	ANSI/FCI 70-2
Valve testing	ISO 5208 et MSS SP-61
Fire safe testing	API 607/5 – ISO 10497-5
Actuator attachments	ISO 5211

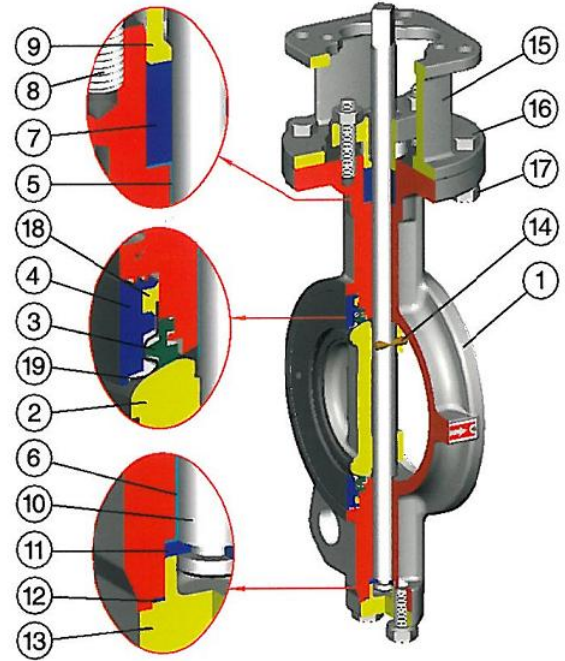

CONSTRUCTION

#	Item	Materials 1113	Materials 1114
1	Body	Carbon steel A216 WCB / 1.0619	Stainless steel A351 CF8M / 1.4408
2	Butterfly	Stainless steel A351 CF8M / 1.4408	
3	Seat	PTFE + 15 % Graphite	
4	Retainer	Stainless steel 1.4308	
5	Ring	PTFE + Stainless steel	
6	Ring	PTFE + Stainless steel	
7	Packing	Graphite	
8	Stud	ASTM A 193 B8	
9	Gland plate	Stainless steel 1.4308	
10	Stem	Stainless steel 364 630	
11	Thrust ring	Stainless steel ASTM A240 Gr. 316	
12	Gasket	Graphite	
13	Bottom cover	Carbon steel A216 WCB / 1.0619	Stainless steel A351 CF8M / 1.4408
14	Pin	ASTM A 182 F316	
15	Bracket	Carbon steel A216 WCB / 1.0619	Stainless steel A351 CF8M / 1.4408
16	Stud	ASTM A 193 B8	
17	Nut	ASTM A 194 B8	
18	Tightness	Graphite	
19	Metal seat	Stainless steel ASTM A240 Gr. 316	

The following data is for information purpose only and may be subject to alteration without prior notice

	SECTORIEL S.A. 45, rue du Ruisseau 38290 Saint Quentin-Fallavier – FRANCE Tel.: +33 474 94 90 70 – Fax: +33 474 94 13 95 www.sectoriel.fr / email: sectoriel@sectoriel.fr	Nbr. pages	2/4
		Ref.	1113+NA GB
		Rev.	4
		Date	09/2011

1113-1114 BUTTERFLY VALVES + NA ELECTRIC ACTUATOR

DIMENSIONS (mm)

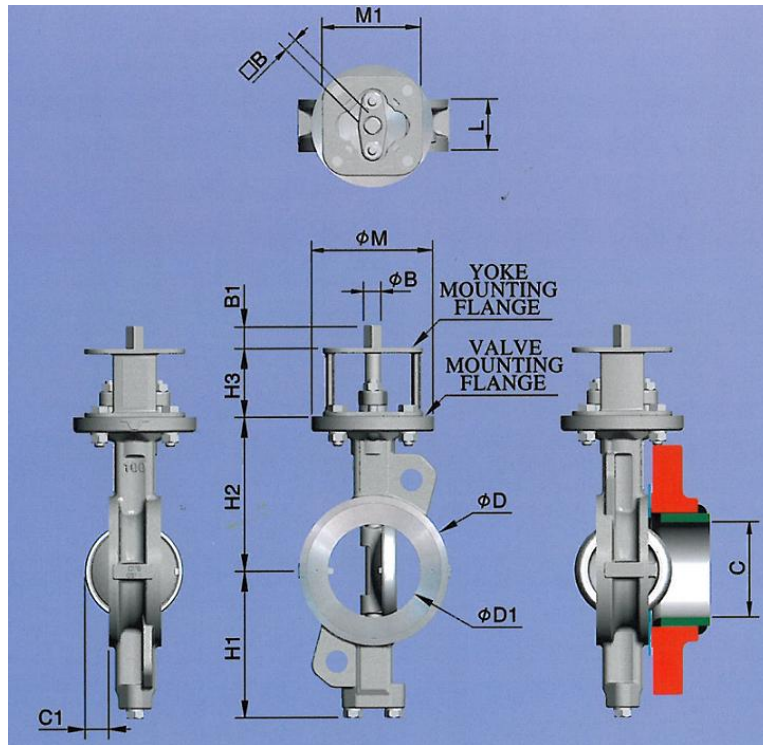

DN	L	H1	H2	H3	Ø D	Ø D1	C	C1	Weight (Kg)
50	43	99	118	60	92	57	49	2	3.9
65	46	110	125	60	108	63	62	15	4.5
80	47	128	140	70	126	78	78	22	7
100	53	150	157	70	153	95	93	25	9
125	57	163	170	70	184	118	120	36	12
150	56	176	185	70	212	143	149	50	13.5
200	62	206	220	80	268	188	196	70	22
250	68	238	260	80	326	236	243	90	32
300	78	269	290	100	375	282	289	106	48

FLOW FACTOR Kv (m³/h)

DN	50	65	80	100	125	150	200	250	300
Kv	56	119	222	358	615	1709	1709	2649	4059

The following data is for information purpose only and may be subject to alteration without prior notice

	SECTORIEL S.A. 45, rue du Ruisseau 38290 Saint Quentin-Fallavier – FRANCE Tel.: +33 474 94 90 70 – Fax: +33 474 94 13 95 www.sectoriel.fr / email: sectoriel@sectoriel.fr	Nbr. pages	3/4
		Ref.	1113+NA GB
		Rev.	4
		Date	09/2011

1113-1114 BUTTERFLY VALVES + NA ELECTRIC ACTUATOR

ACTUATION WITH NA

Suggested standard NA actuation under the following conditions:

- Electric actuator with an IP 67 epoxy coated aluminium enclosure and steel gears
- A minimum 1.3 safety factor compared with the valve nominal torque rating
- A maximum pressure differential up/downstream of 10 bar (=ΔP)





The actuator is mounted with steel bracket and coupler

DN	Actuator	Power	Operating Time*	Standard equipment of the actuator
50	NA06	15 W	17 s	2 adjustable limit switches + 2 dry auxiliary switches 20 W anti-condensation heater Visual position indicator Actuator thermal cut-out (NA06 and NA09) Torque limiter (NA15 to NA38) Electrical connection: 2 gland packs M20 x 1.5 Manual override by declutchable handwheel
65	NA06	15 W	17 s	
80	NA09	25 W	17 s	
100	NA09	25 W	17 s	
125	NA15	40 W	20 s	
150	NA28	40 W	24 s	
200	NA28	40 W	24 s	
250	NA38	60 W	24 s	
300	NA38	60 W	24 s	

*Unloaded operating time given for information purpose only. May vary depending on the medium
 For any other working conditions, please contact us.

ACTUATION OPTIONS

There are many different options, please contact our commercial department.

1	2	3	4	5
NALCU: Actuator with a local control	NAPCU: regulation actuator 4-20 mA or 0-10 V	NARBP: Safety actuator with an integrated battery emergency shutdown	NA-X: Actuator for use in ATEX zones 1 and 2	SR: Safety spring return actuator
				
6	Electric actuator sized for a maximum pressure differential up/downstream over 10 bar (=ΔP)			
7	NA electric actuator with a declutchable manual override by handwheel			
VALVE OPTIONS				
1	Locating holes drilling according to EN 1092-1 standard for PN16 flanges and according to ANSI B16.5 standard for ANSI 150			
2	Lug connections			

ATEX ZONES INSTALLATION

It is compulsory to specify if the installation of the automatic valve 1113-1114+NA-X will take place in ATEX zones 1 or 2 while making the order. Our services will proceed to the mounting check, to a grounding strip installation and will edit a mounting certificate. Those operations are performed by our proper engineers. Please contact us for further details. It is also compulsory to follow the ATEX zone mounting and maintenance special instructions for motorized valves. The ATEX gland packs and sealing plugs are not provided. Please use the following codes:

ATEX aluminium gland pack M20x1.5	Code 980179	ATEX aluminium sealing plugs M20x1.5	Code 980180
-----------------------------------	-------------	--------------------------------------	-------------

The following data is for information purpose only and may be subject to alteration without prior notice

	SECTORIEL S.A. 45, rue du Ruisseau 38290 Saint Quentin-Fallavier – FRANCE Tel.: +33 474 94 90 70 – Fax: +33 474 94 13 95 www.sectoriel.fr / email: sectoriel@sectoriel.fr	Nbr. pages	4/4
		Ref.	1113+NA GB
		Rev.	4
		Date	09/2011

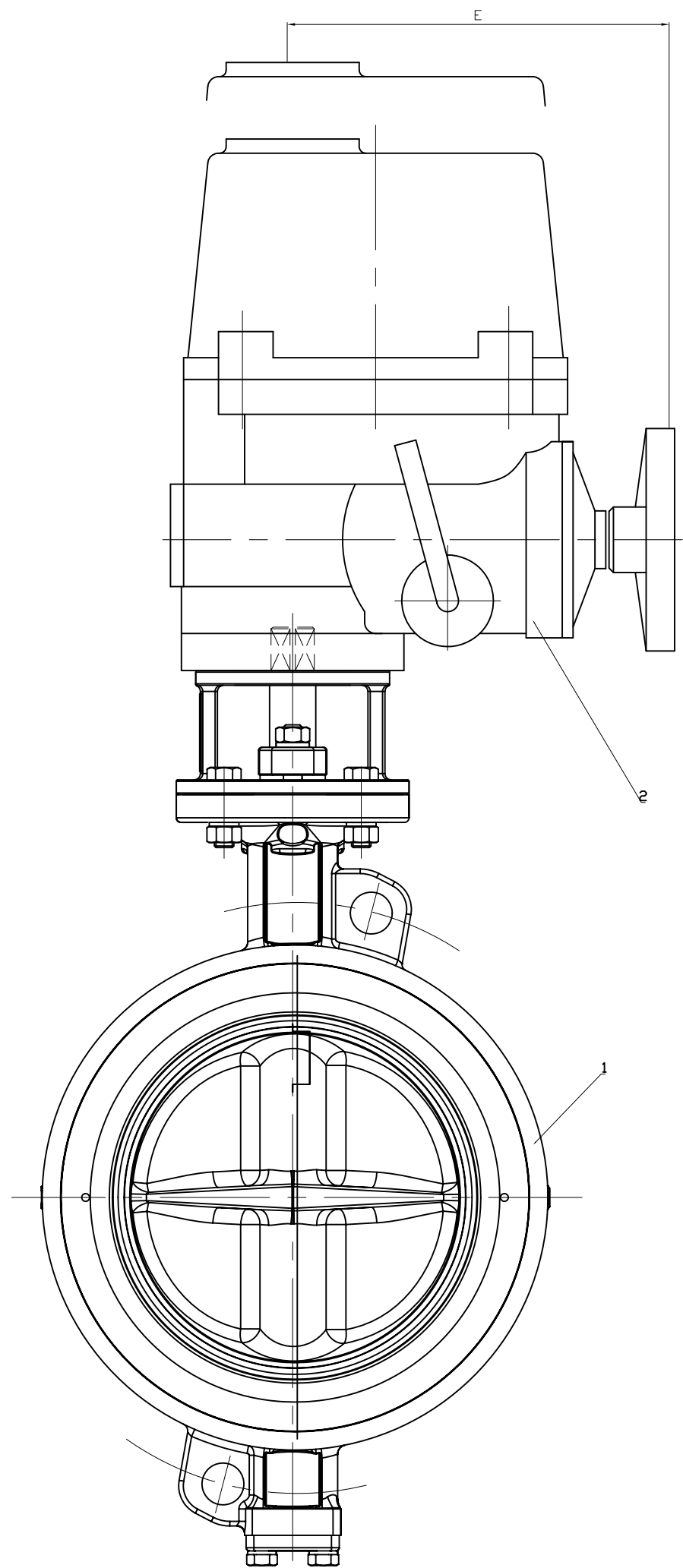
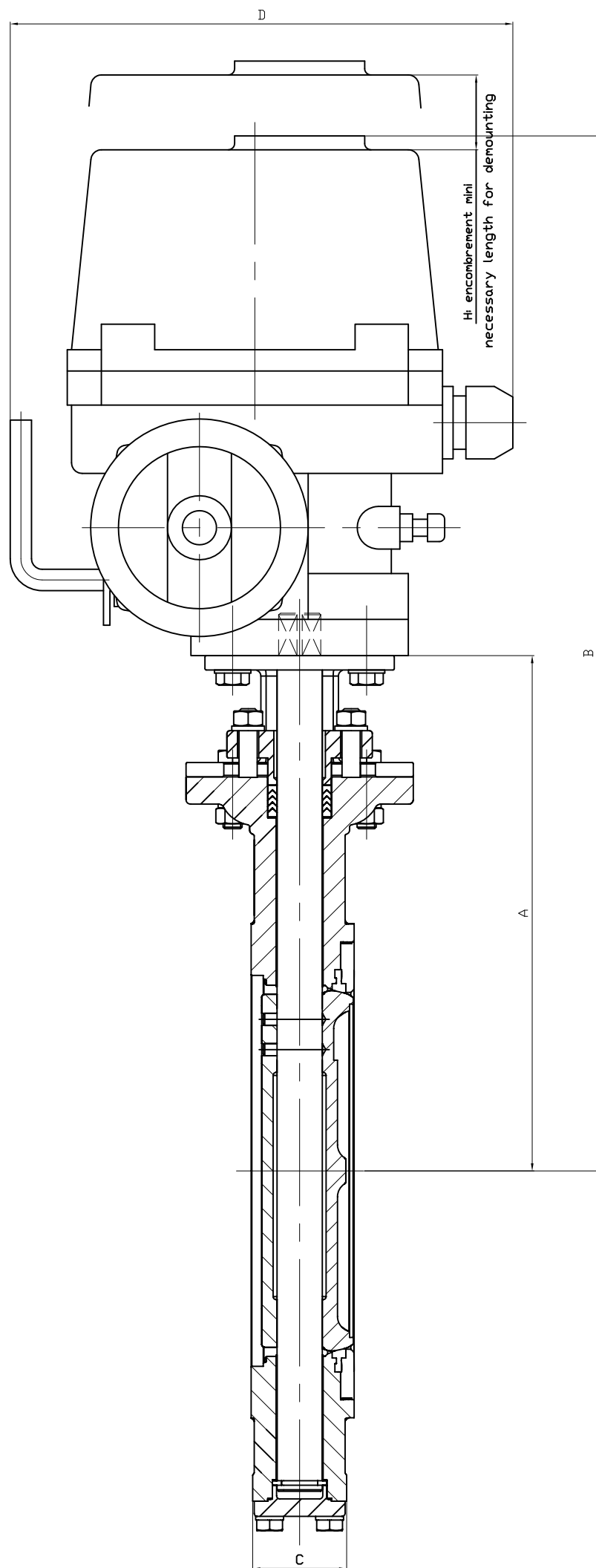

DN	50	65	80	100	125	150	200	250	300
NA-NAX	06	06	06	09	15	28	28	38	38
A	178	185	210	227	240	255	300	340	390
B	433	440	465	482	542	557	682*	642	692
C	43	46	47	53	57	56	62	68	78
D	223	223	223	223	266	300	300	300	300
E	175	175	175	175	184	202	202	202	202
H	108	108	108	108	108	130	130	130	130
Poids Kg	14.9	15.5	18	20	24	30.5	40.5	50	66
1	Robinet à papillon à double excentration								
2	Servomoteur électrique NA-NAX								

* DN200 Montage avec platine supplémentaire H=80mm

Ech: /		Date :24/11/2009	Dessiné par : E.D.	Tolérances générales : +/- 0.2	Ajout DN50 - Révision des motorisations	26/09/2011	A
Robinet à papillon à double excentration 1113-1114 + Servomoteur électrique NA-NAX					Modifications		
Double eccentric butterfly valve 1113-1114 + NA-NAX electrical actuator					Date		
 45, Rue du Ruisseau 38297 SAINT QUENTIN FALLAVIER					REV.		
					Matière :		
					Poids (Kg) :		
					Traitement : SANS		
					Plan n° Ens 1058A		

ELECTRIC ACTUATOR TYPE NA / NA-X

GENERAL CHARACTERISTICS

The NA electric actuator is dedicated to the actuation of industrial ¼ turn valve. The maximum torque value is 2500 Nm. With a compact design, an IP 67 cast aluminium enclosure and an epoxy protection, the NA electric actuator is especially adapted to the actuation of ball valves and butterfly valves in dusty outdoor or indoor areas. It is equipped with a declutchable manual override and a torque limiter (except on NA06 and NA09). Many options are available. The NA-X version can be used in explosive areas 1 and 2 and complies with the EN 15714-2 standard.

AVAILABLE MODELS

NA06: 60 Nm to NA250: 2500 Nm

Voltage: 230 V AC, 400 V AC, 24 V AC, 24 V DC

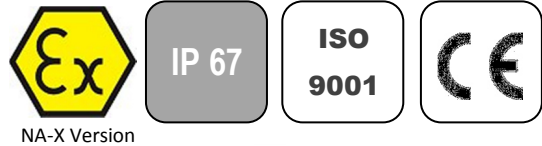

LIMITS OF USE

Version	NA	NA-X
Protection rating	IP 67	
Temperature range	-20 °C / +70 °C	-20 °C / +55 °C
Service	S2-70%	
Explosive areas	Forbidden	Zone 1 and 2



MECHANICAL CHARACTERISTICS

Gears	Treated steel pinions
Rotation angle	90° +/- 5°
Declutching	Lever
Manual override	Handwheel
Torque limiter	Except for NA06 and NA09

Electric actuator	NA06	NA09	NA15	NA28	NA38	NA60	NA100	NA150	NA200	NA250
Torque	60 Nm	90 Nm	150 Nm	280 Nm	380 Nm	600 Nm	1000 Nm	1500 Nm	2000 Nm	2500 Nm
Operating time	17 s	17 s	20 s	24 s	24 s	29 s	29 s	87 s	87 s	87 s
ISO 5211 pad	F07	F07	F07/F10	F10/F12	F10/F12	F12/F14	F12/F14	F14/F16	F14/F16	F14/F16
Star drive nut	17	17	17	22	27	27	27	36	36	46

DIRECTIVES AND DEVELOPMENT STANDARDS APPLICABLE

Machine 2006/42/EC	Actuator attachments : ISO 5211
Low Voltage Directive 2006/95/EC	Electromagnetic compatibility 2004/108/EC
ATEX 1994/9/EC: ATEX II 2 G EEx d II B T4 – NEMKO 03ATEX1342X (NA-X electric actuator only)	

The following data is for information purpose only and may be subject to alteration without prior notice

	SECTORIEL S.A. 45, rue du Ruisseau 38290 Saint Quentin-Fallavier – FRANCE Tel.: +33 474 94 90 70 – Fax: +33 474 94 13 95 www.sectoriel.fr / email: sectoriel@sectoriel.fr	Pages	1/4
		Ref.	FT23110 GB
		Rev.	5
		Date	06/2012

ELECTRIC ACTUATOR TYPE NA / NA-X

CONSTRUCTION

1	Position indicator	Polycarbonate
2	Condenser	
3	Terminal block	
4	Limit switches	
5	Body / cover	Aluminium alloy
6	Base / enclosure	Aluminium alloy
7	Drive nut	Steel
8	Dome	Polycarbonate
9	Electric motor	
10	Anti-condensation heater	
11	Handwheel	Steel
12	Manual override	Steel
13	Declutching lever	Steel
14	Worm gear	Steel

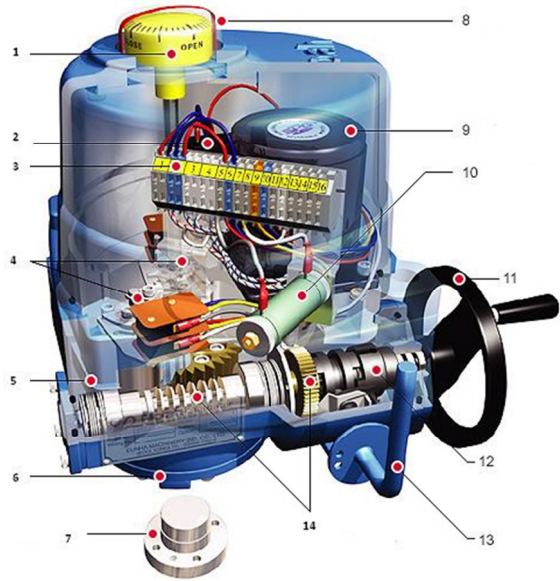

ELECTRICAL CHARACTERISTICS

Motor Protection	Thermal cut-out	Anti-condensation	20 W heater
Limit switches	2 adjustable switches	Electrical connection	2 gland packs M20x1.5
Auxiliary switches	2 dry adjustable switches		

Electric actuator	NA06	NA09	NA15	NA28	NA38	NA60	NA100	NA150	NA200	NA250
Power	15 W	25 W	40 W	40 W	60 W	90 W	180 W	98 W	180 W	180 W
Voltage	380 V – 50 Hz									
Hold current	0.13 A	0.18 A	0.3 A	0.3 A	0.33 A	0.52 A	0.73 A	0.52 A	0.73 A	0.73 A
Inrush current	0.23 A	0.36 A	0.59 A	0.74 A	0.78 A	1.24 A	1.68 A	0.78 A	1.68 A	1.68 A
Voltage	220 V – 50 Hz									
Hold current	0.45 A	0.58 A	0.95 A	0.95 A	1.3 A	1.5 A	2.15 A	1.5 A	2.15 A	2.15 A
Inrush current	0.63 A	0.89 A	1.12 A	1.37 A	1.85 A	2.34 A	3.4 A	2.34 A	3.4 A	3.4 A
Voltage	24 V – 50 Hz									
Hold current	3.2 A	4.3 A	6.5 A	8.1 A						
Inrush current	6 A	8 A	12 A	14 A						
Voltage	24 V DC									
Hold current	2.2 A	3.5 A	4.5 A	6.5 A						
Inrush current	4.1 A	4.1 A	6.6 A	13.8 A						

The following data is for information purpose only and may be subject to alteration without prior notice

	SECTORIEL S.A. 45, rue du Ruisseau 38290 Saint Quentin-Fallavier – FRANCE Tel.: +33 474 94 90 70 – Fax: +33 474 94 13 95 www.sectoriel.fr / email: sectoriel@sectoriel.fr	Pages	2/4
		Ref.	FT23110 GB
		Rev.	5
		Date	06/2012

ELECTRIC ACTUATOR TYPE NA / NA-X

DIMENSIONS (mm)

NA06 to NA100

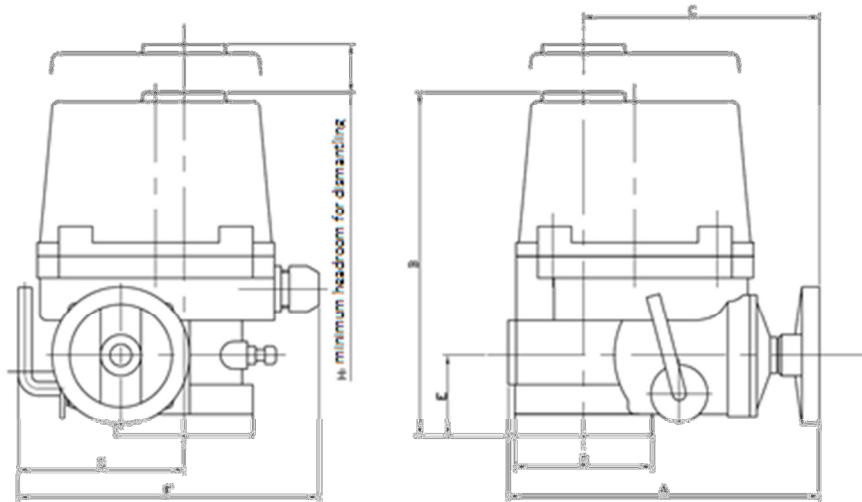

NA150 to NA250

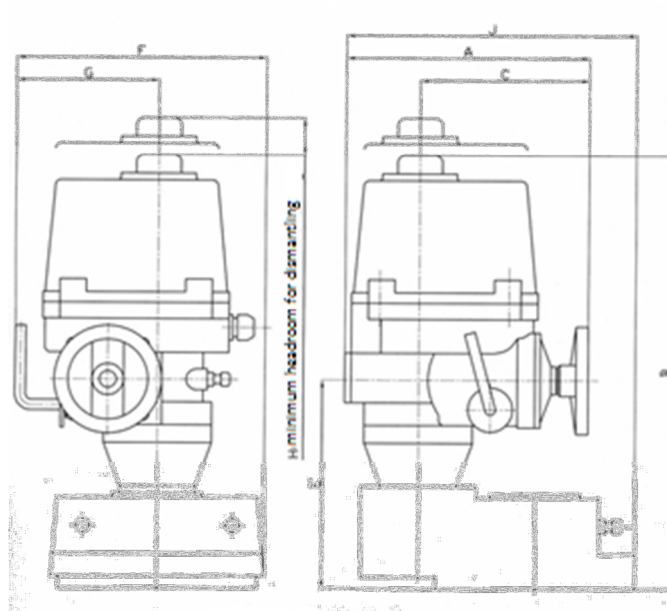

NA	A	B	C	D	E	F	G	H
NA06 - NA09	231	255	175	102	60	223	113	108
NA15	261	255	184	120	60	266	139	108
NA28 - NA38	285	302	202	145	70	300	159	130
NA60 - NA100	325	343	226	175	78	349	191	178
NA150 - NA200 - NA250	325	556	226	-	273	388	191	178

The following data is for information purpose only and may be subject to alteration without prior notice

	SECTORIEL S.A. 45, rue du Ruisseau 38290 Saint Quentin-Fallavier – FRANCE Tel.: +33 474 94 90 70 – Fax: +33 474 94 13 95 www.sectoriel.fr / email: sectoriel@sectoriel.fr	Pages	3/4
		Ref.	FT23110 GB
		Rev.	5
		Date	06/2012

ELECTRIC ACTUATOR TYPE NA / NA-X

OPTIONS

1	NAPIU : feedback potentiometer version
2	NACPT: 4-20 mA position transmitter version
3	NAPCU: 0-10, 2-10 V, 2-20 mA, 4-20 mA regulation card version
4	NALCU: local control version
5	NARBP: integrated battery emergency shutdown device version
6	Earthquake simulation test
7	Low temperature version (-40 °C)
8	IP 68 version
9	Rotation angles 120°, 135°, 180°, 270°

The following data is for information purpose only and may be subject to alteration without prior notice

	SECTORIEL S.A. 45, rue du Ruisseau 38290 Saint Quentin-Fallavier – FRANCE Tel.: +33 474 94 90 70 – Fax: +33 474 94 13 95 www.sectoriel.fr / email: sectoriel@sectoriel.fr	Pages	4/4
		Ref.	FT23110 GB
		Rev.	5
		Date	06/2012