



## High alloyed Stainless steel valve with PTFE seat

DN 65 to 600 (2½ to 24")

Pressure Class: Class 150 and B 25

Design in accordance with ASME B16.34

### Applications

- Mining,
- Fertilizers,
- Acid manufacturing applications,
- Paper and cellulose industry.

### Working conditions

- Temperature :  
from -29 °C min. up to +220 °C max.  
The working temperature depends on the material of the seat.  
For upper temperatures, please consult us.
- Allowable pressure (PS) : 25 bar, at ambient temperature.
- Vacuum service down to 0 absolute bar.
- Maximum fluid velocity under allowable pressure:  
4 m/s for liquids and 50 m/s for clean gases.

### Materials

See page 2.

### Design

- Wafer type body (Type 1): DN 65 to 600
- Full-lug type body with raised faces (Type 4): DN 65 to 600
- Seat: reinforced PTFE.
- Double-eccentric kinematics.
- Face-to-face in accordance with EN 558 series 20, ISO 5752 series 20 (except DN 350 : ISO 5752 series 25) and API 609 table 2 standards.
- Possible mounting between flanges according to EN 1092-1, ASME. See page 10.
- Actuation mounting plate in accordance with ISO 5211 and NF E 29-402 standards.

- Downstream/upstream tightness in accordance with standards referred page 3.
- Perfectly tight shut-off valves (zero leakage visible to the naked eye) in the two flow directions in accordance with EN 12266-1 leak level A and ISO 5208 category A standards.
- Corrosion protection: pickling and passivation of bodies.

### Standard variants

- 1/4-turn handles "S" series
- Manual actuator MN / MR
- Pneumatic actuator ACTAIR / DYNACTAIR
- Electric actuator ACTELEC
- Hydraulic actuator ACTO / DYNACTO / ENNACTO
- Position detection AMTROBOX
- Pneumatic distribution for On-Off function AMTRONIC
- Positioner and control unit SMARTRONIC

### Remarks

- Operating instructions 8450.810/-10

### Data to be supplied when ordering

- DANAIS 150D valve in accordance with Type series booklet 8460.13/01-10.
- Size, Materials (body, disc, seat).
- Working conditions: nature of fluid, pressure, flow, etc.
- Connection, flange facing finish, etc.
- Actuation.



## Materials

Body	Temperature refer to § Pressure / temperature below	KSB code
Austenitic stainless steel ASTM A351 gr. CK3MCUN (254 SMO)	-29 °C to +260 °C	7D
Shaft		KSB code
Duplex 1.4547 (254 SMO)	-50 °C to +260 °C	7D
Disc		KSB code
Austenitic stainless steel ASTM A 351 gr. CK3MCUN (254 SMO)	-29 °C to +260 °C	7D
AMRING® seat		KSB code
Reinforced PTFE	-50 °C to +220 °	FB

## Pressure / temperature

In pressure class 150 (ASTM materials), DANAIS 150D valves meet ASME B 16-34 cl.150 "Standard class" requirements, according to the following table:

Pressure Class	Material		Working pressure in bar at temperature °C					
	Body	Seat	-29	38	100	150	200	220
Class 150	A 351 gr. CK3MCUN	PTFE	20,0	20,0	17,7	15,8	3,3	0,0

### Kinematics

The compression of the seating disc edge onto the seat is achieved by double-eccentric kinematics. The axis of the shafts is off-set to valve axis and eccentric to pipe axis. This design eliminates the possibility of friction during operation and, as a result ensures long lasting service while maintaining tight shut-off characteristics. These tight shut-off characteristics conform to the most exacting requirements and standards.

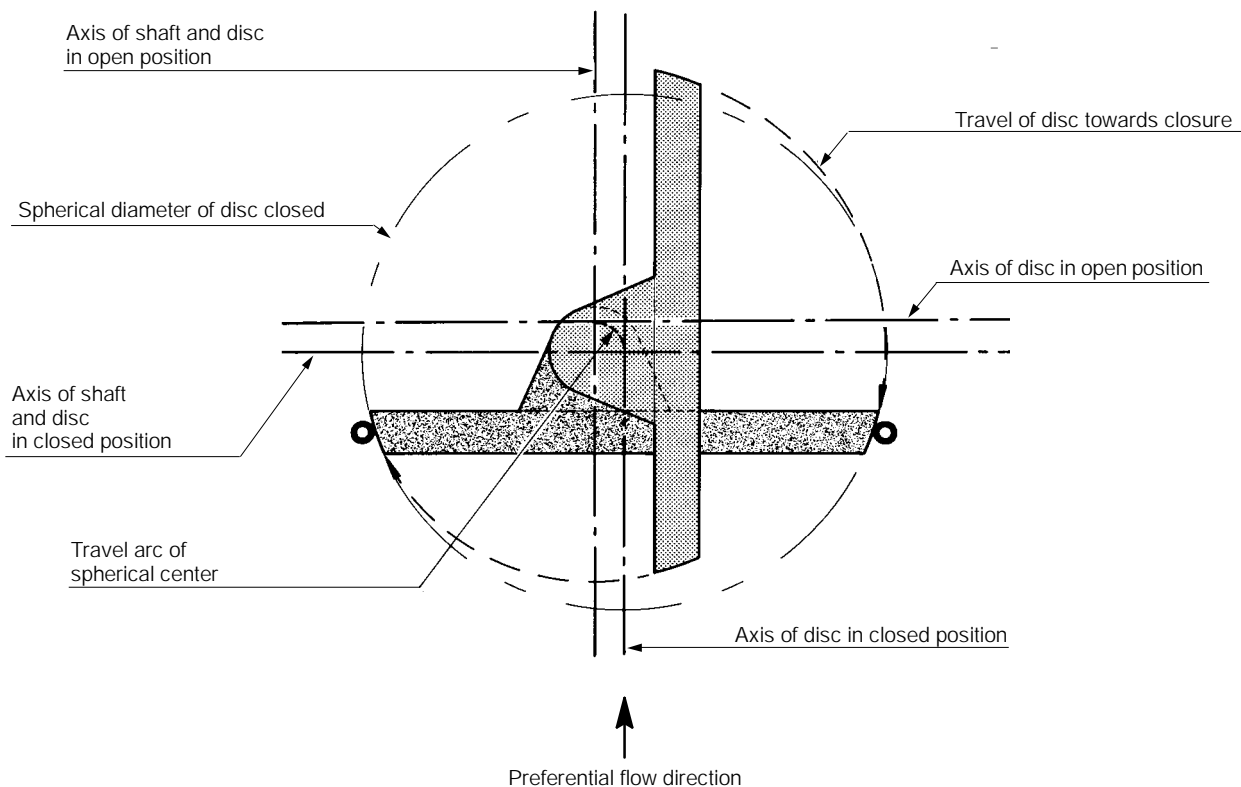

### Upstream/downstream sealing

The DANAIS 150T valve conforms to the following sealing standards. The DANAIS 150T valve is a bi-directional valve with a preferential flow direction shown by an arrow (differential pressure direction on the disc).

Valve	With PTFE seat
On liquid	EN 12266 category A ISO 5208 category A API 598
On gas	EN 12266 category A ISO 5208 category A API 598 ANSI / FCI 70.2 class VI

Construction

DN 65 to 300 (2½" to 12")

DN 350 to 600 (14" to 24")

Flat shaft end  
DN 50 to 200  
2" to 8"

Square shaft end  
DN 250 and 300  
10" and 12"

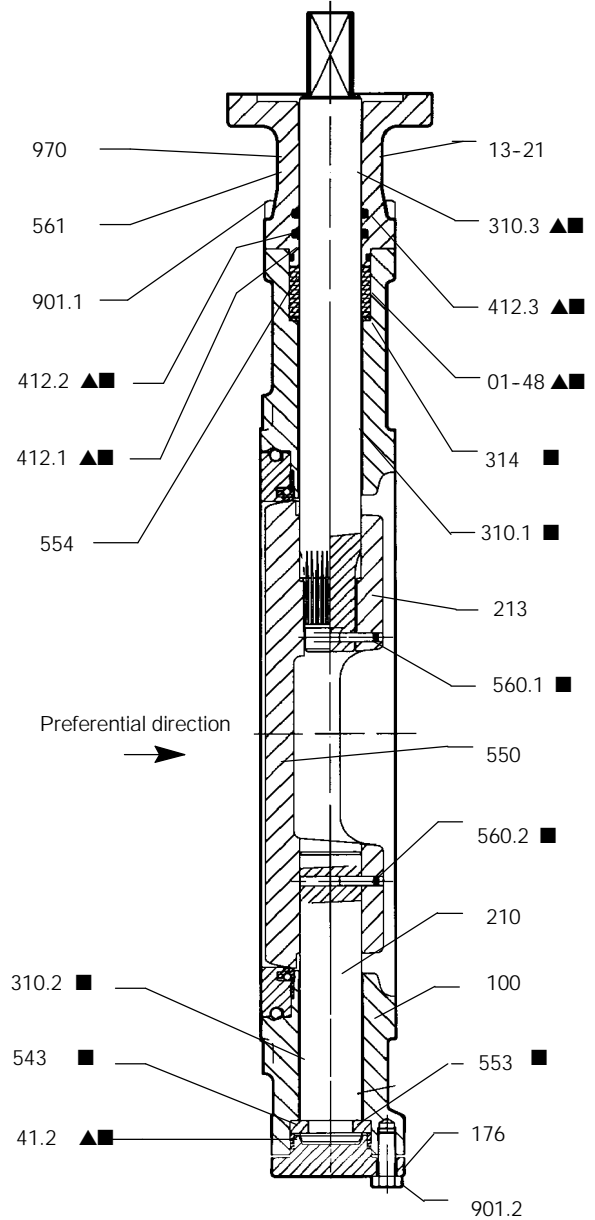
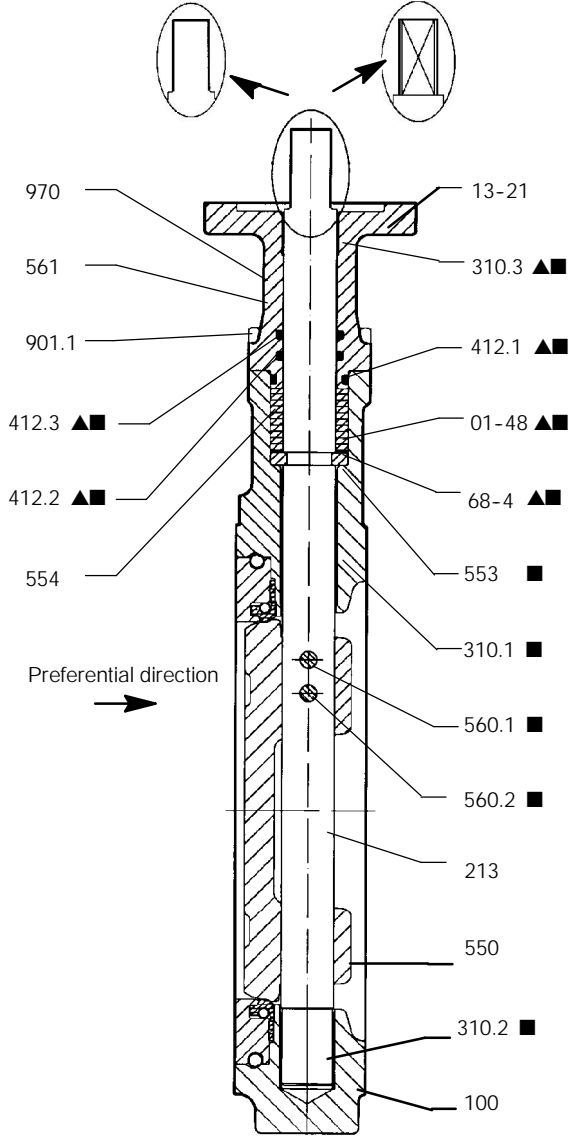

PTFE seat

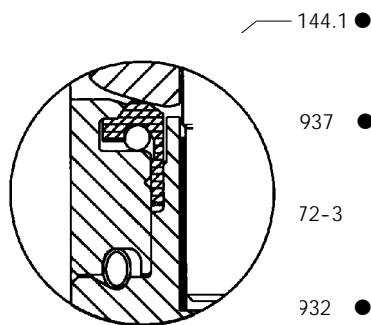

● Spare parts kit for seat    ▲ Spare parts kit for sealing packing    ■ Spare parts for guiding

**Parts list**

Item	Designation	DN	Materials
01-48	Sealing packing	65 to 600	PTFE
100	Body	65 to 600	Austenitic stainless steel ASTM A 351 gr. CK3MCUN
13-21	Extension	65 to 600	Stainless steel ASTM A 351 gr. CF 8M
144.1	Seat	65 to 600	Filled PTFE
176	Bottom	350 to 600	Austenitic Stainless steel ASTM A 351 gr. CK3MCUN
210	Shaft	350 to 600	Stainless steel 1.4547
213	Driving shaft	65 to 600	Stainless steel 1.4547
310.1	Upper plain bearing	65 to 600	Stainless steel + PTFE
310.2	Lower plain bearing	65 to 600	Stainless steel + PTFE
310.3	Lower plain bearing	350 to 600	Stainless steel + PTFE
314	Thrust washer	350 to 600	Stainless steel 1.4547
412.1	O-Ring	65 to 600	Viton®
412.2	O-Ring	65 to 600	Viton®
412.3	O-Ring	65 to 600	Viton®
41-2	Static joint	350 to 600	Expanded graphite
543	Spacer bush	350 to 600	Stainless steel 1.4547
550	Disc	65 to 600	Austenitic stainless steel ASTM A 351 gr. CK3MCUN
553	Thrust insert	65 to 600	Stainless steel 1.4547
554	Washer	65 to 600	Stainless steel
560.1	Pin	65 to 600	Stainless steel 1.4547
560.2	Pin	65 to 600	Stainless steel 1.4547
561	Grooved nail	65 to 600	Stainless steel
68-4	Foil	65 to 300	Stainless steel 1.4547
72-3	Tightening flange	65 to 600	Stainless steel 1.4547
901.1	Hexagon-head screw	65 to 600	A4-70 stainless steel
901.2	Hexagon-head screw	350 to 600	A4-70 stainless steel
932	Inner ring	65 to 600	Stainless steel
937	Elastic wire	65 to 600	Hastelloy
970	Identity plate	65 to 600	Stainless steel

**Wafer type body Type 1 - Dimensions**
**DN 65 to 200 (2½" to 8")**
**DN 250 to 400 (10" to 16")**

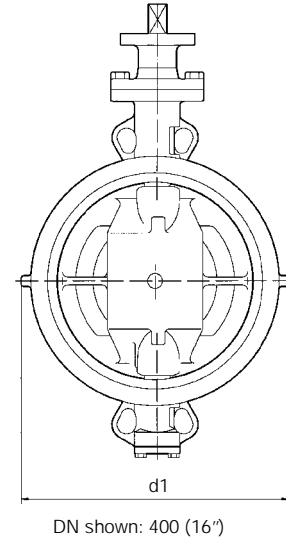
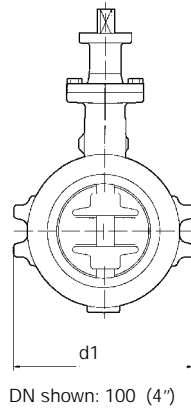
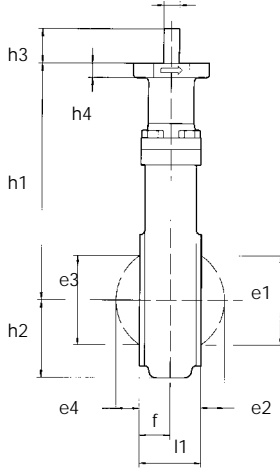
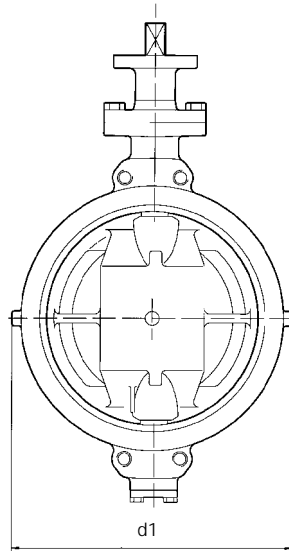
 DN 50 to 200: flat end "s" machined in øz  
 DN ≥ 250: square end "s"

**DN 450 to 600 (18" to 24")**

mm

DN	NPS	Face to face l1	Mounting plate according to ISO 5211				Flat shaft end			Square shaft end		Disc clearance					
			d1	h1	h2	f	n°	h4	s	øz	h3	s	h3	e1	e2	e3	e4
65	2½	46	123	175	60	23,0	F05	10	11	14	24			41	6	48	9
80	3	46	140	185	68	24,0	F05	10	11	14	24			59	13	61	15
100	4	54	180	200	82	27,0	F05	10	14	18	24			78	18	81	21
125	5	57	210	225	92	28,5	F07	12	14	18	30			99	27	103	30
150	6	57	235	240	117	28,5	F07	12	17	22	32			127	39	131	43
200	8	62	271	290	153	34,5	F10	15	19	25	35			177	62	175	59
250	10	70	323	335	182	38,0	F12	18				25	45	225	82	230	80
300	12	80	380	365	230	42,0	F12	18				27	45	265	96	266	98
350	14	92*	449	435	307	47,5	F14	22				30	55	308	112	311	116
400	16	102	505	465	332	56,5	F14	22				36	55	359	133	358	132
450	18	114	570	530	371	61,0	F16	26				40	65	418	155	418	160
500	20	127	629	560	398	64,5	F16	26				40	65	455	167	455	175
600	24	154	730	660	455	77,0	F25	28				50	65	546	201	546	211

\* Face to face according to API 609 table 2 and EN 558 standards

## Full lug type body Type 4 - Dimensions

**DN 65 to 300 (2½" to 12")**
**DN 350 to 600 (14" to 24")**

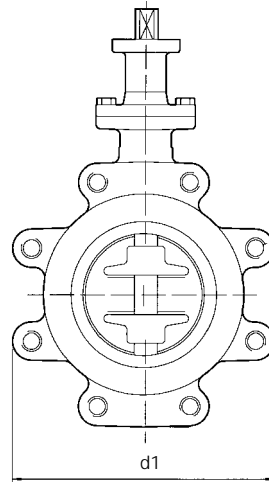
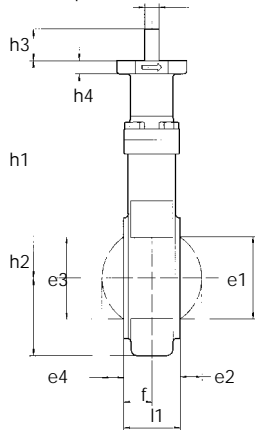
 DN 50 to 200: flat end "s" machined in øz  
 DN ≥ 250: square "s"

DN shown: 100

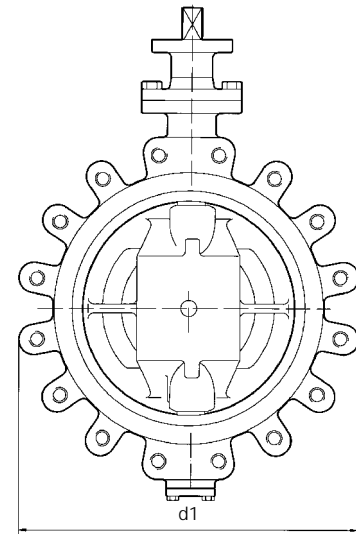

DN shown: 400

mm

DN	NPS	Face to face l1					Mounting plate according to ISO 5211		Flat shaft end			Square shaft end		Disc clearance			
			d1	h1	h2	f	n°	h4	s	øz	h3	s	h3	e1	e2	e3	e4
65 (1)	2 ½	46	131	175	67	23,0	F05	10	11	14	24			41	6	48	9
65 (2)	2 ½	46	162	175	82	23,0	F05	10	11	14	24			41	6	48	9
80 (3)	3	46	136	185	70	24,0	F05	10	11	14	24			59	13	61	15
80 (4)	3	46	176	185	89	24,0	F05	10	11	14	24			59	13	61	15
100	4	54	206	200	104	27,0	F05	10	14	18	24			78	18	81	21
125	5	57	240	225	121	28,5	F07	12	14	18	30			99	27	103	30
150 (1)	6	57	267	240	135	28,5	F07	12	17	22	32			127	39	131	43
150 (2)	6	57	288	240	145	28,5	F07	12	17	22	32			127	39	131	43
200 (5)	8	62	310	290	157	34,5	F10	15	19	25	35			177	62	175	59
250	10	70	410	335	205	38,0	F12	18				25	45	225	82	230	80
300 (6)	12	80	460	365	230	42,0	F12	18				27	45	265	96	266	98
350 (3)	14	92 *	508	435	307	47,5	F14	22				30	55	308	112	311	116
350 (4)	14	92 *	529	435	307	47,5	F14	22				30	55	308	112	311	116
400	16	102	593	465	332	56,5	F14	22				36	55	359	133	358	132
450 (3)	18	114	620	530	371	61,0	F16	26				40	65	418	155	418	160
450 (4)	18	114	649	530	371	61,0	F16	26				40	65	418	155	418	160
500	20	127	705	560	398	65,5	F16	26				40	65	455	167	455	175
600	24	154	822	660	455	77,0	F25	28				55	65	546	201	546	211

- (1) Mounting between flanges EN 1092-1 PN 10 - 4 holes, ASME B16.5 cl.150
- (2) Mounting between flanges EN 1092-1 PN 10 - 8 holes.
- (3) Mounting between flanges ASME B16.5 cl.150.
- (4) Mounting between flanges EN 1092-1 PN 10.
- (5) Mounting between flanges EN 1092-1 PN 10 and ASME B16.5 cl.150.
- (6) Mounting between flanges EN 1092-1 PN 10 and ASME B16.5 cl.150.

## Operating torques

### DANAIS 150D valve with PTFE seat or PTFE fire safe seat

Nm

DN	NPS	Preferential direction		Non preferential direction	
		Differential pressure $\Delta P$ in bar		Differential pressure $\Delta P$ in bar	
		6	10	6	10
65	2 ½	30	30	20	20
80	3	30	40	30	30
100	4	50	50	40	50
125	5	70	80	60	70
150	6	100	110	90	110
200	8	160	180	150	190
250	10	290	340	270	350
300	12	400	470	380	500
350	14	610	720	570	780
400	16	820	980	780	1 060
450	18	1 130	1 370	1 080	1 480
500	20	1 380	1 680	1 320	1 820
600	24	2 210	2 720	2 130	3 000

\* The safety coefficient to define the adapted actuator is included in the torque value.

## Hydraulic characteristics

DN	NPS	Flow coefficient in fully open position		Zeta
		Kv <sub>0</sub>	Cv <sub>0</sub>	
65	2 ½	110	145	2,35
80		190	220	1,81
100		340	400	1,38
125		600	700	1,08
150	6	980	1 150	0,84
200	8	1 850	2 150	0,75
250	10	3 350	3 880	0,56
300	12	4 870	5 650	0,55
350	14	7 070	8 200	0,48
400	16	10 350	12 000	0,38
450	18	12 500	14 500	0,42
500	20	15 090	17 500	0,44
600	24	22 410	26 000	0,41



**Standard variants**

**ACTO hydraulic actuator**

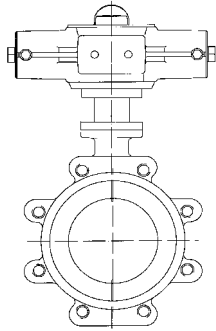

**ACTO hydraulic actuator  
+ AMTROBOX R**

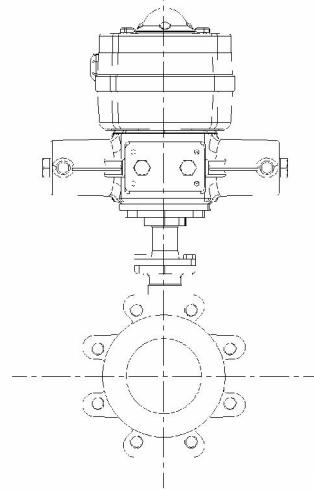

**MR manual actuator**

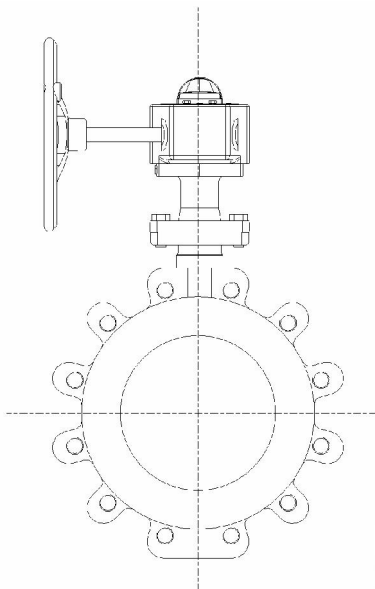

**MR manual actuator  
+ AMTROBOX R**

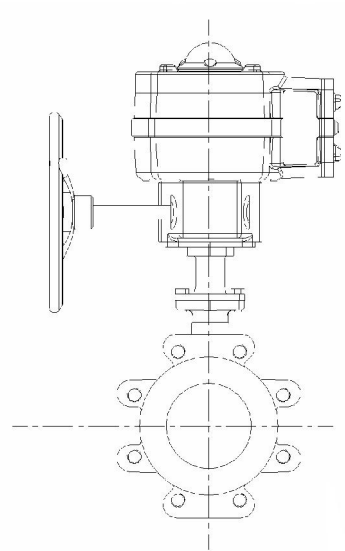

## Connections

The table below defines the possible connections. Please consult us for other connections.

### Wafer type body - Type 1 -

DN	NPS	EN 1092-1 PN 10	ASME B16.5 cl.150
65	2 ½	✓	✓
80	3	✓	✓
100	4	✓	✓
125	5	✓	✓
150	6	✓	✓
200	8	✓	✓
250	10	✓	✓
300	12	✓	✓
350	14	✓	✓
400	16	✓	✓
450	18	✓	✓
500	20	✓	✓
600	24	✓	✓

### Lug type body - Type 4 -

DN	NPS	EN 1092-1 PN 10	ASME B16.5 cl.150
65	2 ½	✓	✓
80	3	✓	✓
100	4	✓	✓
125	5	✓	✓
150	6	✓	✓
200	8	✓	✓
250	10	✓	✓
300	12	✓	✓
350	14	✓	✓
400	16	✓	✓
450	18	✓	✓
500	20	✓	✓
600	24	✓	✓

Connection allowed

## Face-to-face dimensions

The face-to-face dimensions of DANAIS 150D valve are in accordance with the following standards.

DN	Standards
65 (2 ½") to 300 (12"), 400 (16") to 600 (24")	API 609 table 2 class 150, ISO 5752 series 20, EN 558-1 series 20
350 (14")	API 609 table 2 class 150, ISO 5752 series 25, EN 558-1 series 20

## Flange sealing

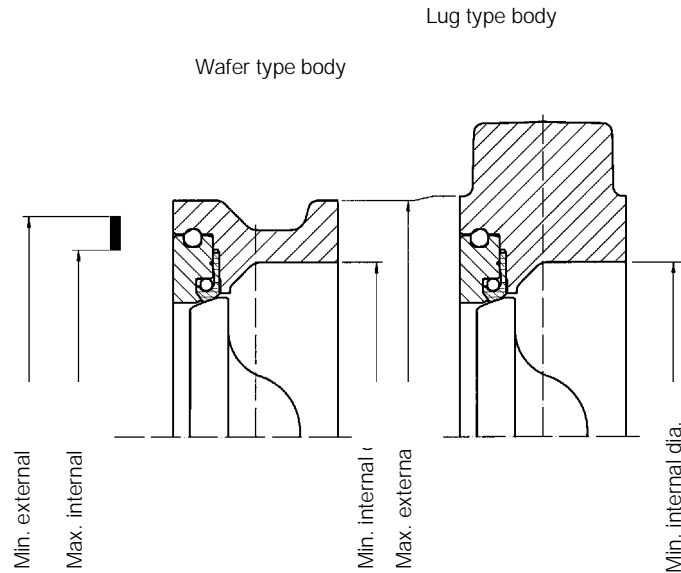

DN	NPS	Flange sealing					Connections	
		Min. area Max. internal dia.	Min. area Min. ext. dia.	Min. area Min. int. dia.	Max. area Max. external dia. Wafer type	Max. area Max. external dia. Full lug type body	T1	T4
65	2 ½	83,6	98,6	75	108,0	104,0	PN 10/16 - ASME B16.5 cl 150 - JIS 10K	
						117,0		PN 25 - JIS 16K/20K
80	3	101,2	116,6	91	125,0	126,0	ASME B 16.5 cl150	
						131,0	PN 10/16/25 - JIS 10K/16K/20K	
100	4	126,6	142,6	117	154,0	156,5	PN 10/16/25 - ASME B16.5 cl 150 - JIS 10K/16K/20K	
125	5	153,6	169,6	144	183,0	185,0		
150	6	180,6	199,1	171	214,0	215,0		
200	8	231,5	253,5	222	267,0	269,0	PN 10 - ASME B 16.5 cl150	
						265,0	PN 16/25 - JIS 10K/16K/20K	
250	10	286,9	305,5	275	321,5	323,0	PN 10/16/25 - ASME B16.5 cl 150 - JIS 10K/16K/20K	
300	12	339,3	358,5	327	377,0	380,0	PN 10/16 - ASME B16.5 cl 150	
						388,0	PN 25 - JIS 10K/16K/20K	
350	14	374,6	400,0	359	411,5	412,0	ASME B16.5 cl 150	
						428,0	PN 10/16/25 - JIS 10K/16K/20K	
400	16	425,9	452,0	410	467,5	469,0	PN 10/16/25 - ASME B16.5 cl 150 - JIS 10K/16K/20K	
450	18	478,5	510,0	461	530,5	532,5		
500	20	528,0	562,0	512	581,5	583,5		
600	24	635,0	671,0	614	689,5	691,5		

Note : The use of spiral -wound gaskets according to ISO 7483 - PN 10 is recommended for DN ≤ 600.

## Wafer type body - Type 1 - Bolting

The bolting is not supplied

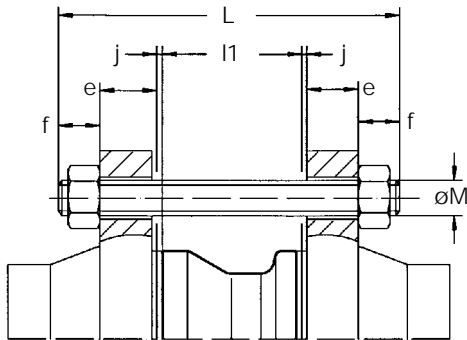

$$L = l1 + 2e + 2f + 2j$$

- L : tie-rod length
- l1 : valve face-to-face
- e : flange thickness
- f : tie-rod overlength
- j : flange gasket thickness

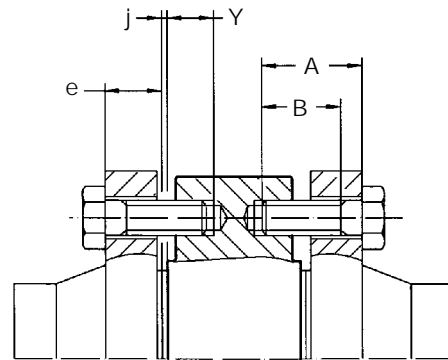

Screws at shaft passages (DN 450)

$$A \text{ max.} = e + Y + j$$

- A max.: screw length
- e : flange thickness
- j : flange gasket thickness
- Y : screw max. implantation
- B : min. threaded length B > A-e

DN	NPS	l1	d1	EN 1092-1 PN 10					Weight
				øM	Tie-rod **		Screw A2		
					f	Qty	Y	Qty*	
65	2 1/2	46	123	M16	20	4/8			3,8
80	3	46	140	M16	20	8			4,5
100	4	54	180	M16	20	8			6,4
125	5	57	210	M16	20	8			9,7
150	6	57	235	M20	24	8			12,7
200	8	62	271	M20	24	8			22,5
250	10	70	323	M20	24	12			34,0
300	12	80	380	M20	24	12			48,8
350	14	92	449	M20	24	16			64,5
400	16	102	505	M24	29	16			89,0
450	18	114	570	M24	29	16	32	4	133,5
500	20	127	621	M24	29	16	35	4	168,0
600	24	154	730	M27	32	16	40	4	270,5

DN	NPS	l1	d1	ASME B 16-5 cl 150					Weight
				UNC	Tie-rod*		Screw A2		
					f	Qty	Y	Qty*	
65	2 1/2	46	123	5/8"	20	4			3,8
80	3	46	140	5/8"	20	4			4,5
100	4	54	180	5/8"	20	8			6,4
125	5	57	210	3/4"	24	8			9,7
150	6	57	235	3/4"	24	8			12,7
200	8	62	271	3/4"	24	8			22,5
250	10	70	323	7/8"	29	12			34,0
300	12	80	380	7/8"	29	12			48,8
350	14	92	449	1"	32	12			64,5
400	16	102	505	1"	32	16			89,0
450	18	114	570	1 1/8"	35	12	40	4	133,5
500	20	127	621	1 1/8"	35	16	39	4	168,0
600	24	154	730	1 1/4"	38	16	48	4	270,5

\* Quantity of nuts = quantity of tie-rods x 2

\*\* Quantity of screws by face

## Full lug type body - Type 4 - Bolting

The bolting is not supplied.

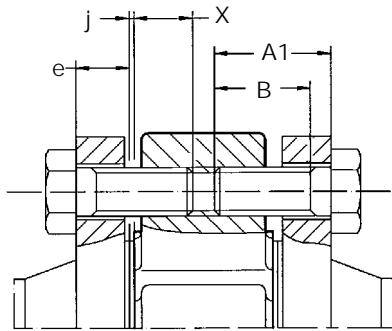

$$A1 \text{ max.} = e + X + j$$

A1 max.: screw length  
 e : flange thickness  
 j : flange gasket thickness  
 Y : screw max. implantation  
 B : min. threaded length  $B > A1 - e$

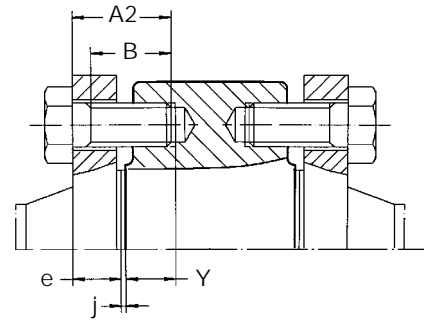

Screws at shaft passages

$$A2 \text{ max.} = e + Y + j$$

A2 max.: screw length  
 e : flange thickness  
 j : flange gasket thickness  
 Y : screw max. implantation  
 B : min. threaded length  $B > A2 - e$

DN	NPS	I1	d1	EN 1092-1 PN 10 (1)					Weight
				øM	Screw A1		Screw A2		
					X	Qty*	Y	Qty*	
65	2 1/2	46	131	M16	22	4			5,2
65	2 1/2	46	162	M16	22	8			6,5
80	3	46	136	M16	20	8			7,4
80	3	46	176						6,0
100	4	54	206	M16	24	8			10,2
125	5	57	240	M16	24	8			14,6
150	6	57	267	M20	27	8			17,2
200	8	62	310	M20	30	8			25,5
200	8	62	338						28,5
250	10	70	410	M20	30	12			44,0
300	12	80	460	M20	30	12			64,8
300	12	80	470						68,8
350	14	92	508	M20	30	16			97,5
350	14	92	529						87,7
400	16	102	593	M24	34	16			130,0
450	18	114	620	M24	32	20			178,5
450	18	114	649						163,5
500	20	127	705	M24	35	20			218,0
600	24	154	822	M27	40	20			355,0

DN	NPS	I1	d1	ASME B16-5 class 150					Weight
				UNC	Screw A1		Screw A2		
					X	Qty*	Y	Qty*	
65	2 1/2	46	131	5/8"	22	4			5,2
65	2 1/2	46	162						6,5
80	3	46	136	5/8"	22	4			6,0
100	4	54	206	5/8"	24	8			10,2
125	5	57	240	3/4"	27	8			14,6
150	6	57	267	3/4"	27	8			17,2
150	6	57	288						20,0
200	8	62	310	3/4"	34	8			25,5
250	10	70	410	7/8"	36	12			44,0
300	12	80	460	7/8"	33	12			64,8
350	14	92	508	1"	37	12			87,7
400	16	102	593	1"	38	16			130,0
450	18	114	620	1 1/8"	40	20			163,5
500	20	127	705	1 1/8"	39	20			218,0
600	24	154	822	1 1/4"	48	20			355,0

\* Quantity of screws by face





Product features - to our customer's benefit

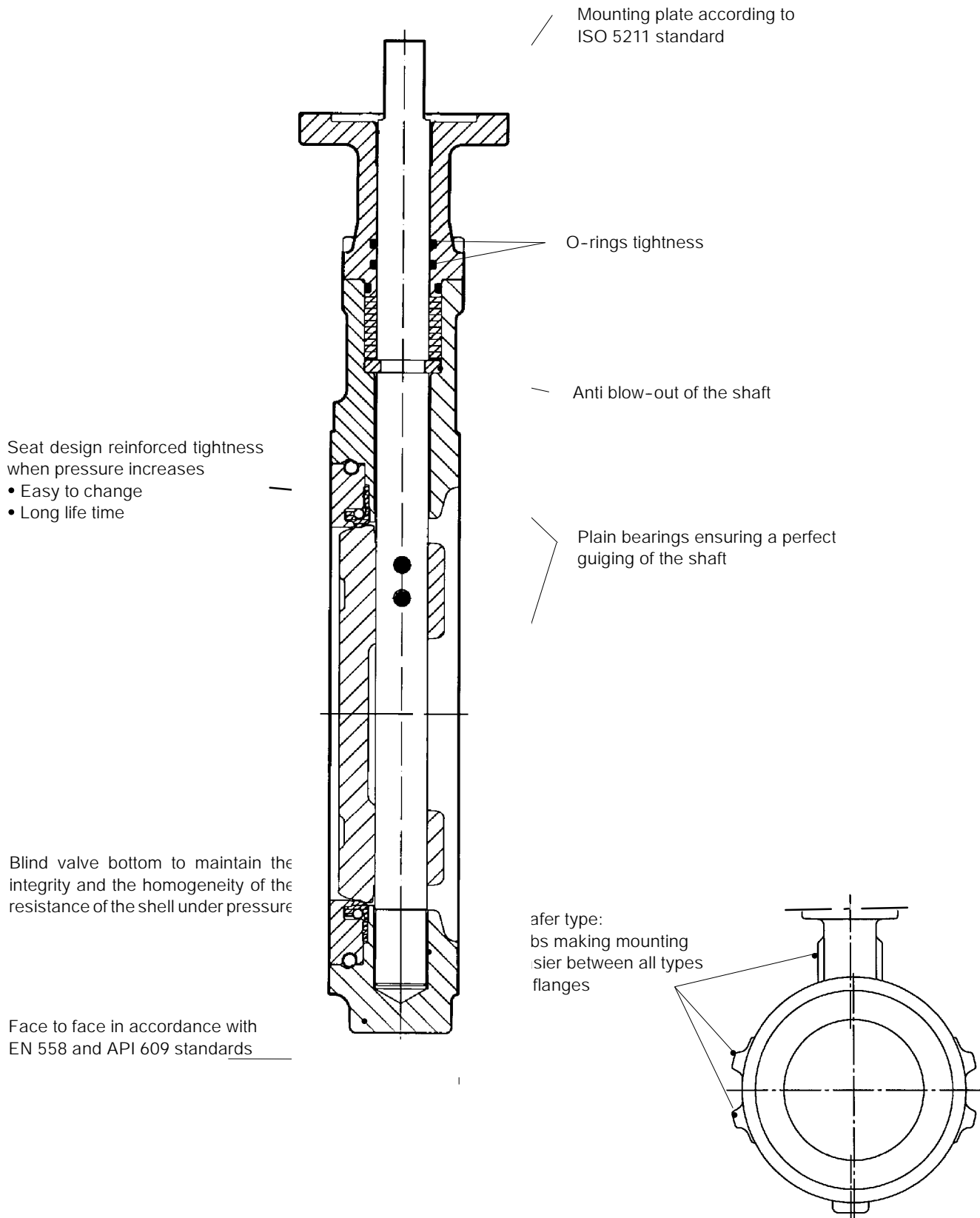

This leaflet is not contractual and may be amended without notice.

22.09.11

8460.13/1 - 10