

ARTICULO: 2104

Válvula de mariposa tipo wafer. Inoxidable 316 + PTFE Butterfly valve wafer type. Stainless Steel 316 + PTFE

Características

1. Válvula de mariposa tipo wafer.
2. Cuerpo bipartido de Inoxidable 316 para montaje entre bridas ANSI 150 y DIN PN 10/16.
3. Asiento de PTFE con base de EPDM
4. Disco de Acero Inoxidable 316 (CF8M).
5. Eje Inoxidable 316.
6. Brida montaje actuadores según ISO 5211.
7. Longitud entre caras según UNE EN 558-1 Serie 20 (DIN 3202 K1).
8. Temperatura de trabajo $-25^{\circ}\text{C} + 180^{\circ}\text{C}$.

Features

1. Butterfly valve wafer type.
2. AISI 316 body in two parts, allows installation in ANSI 150 and DIN PN 10/16 pipe flange.
3. PTFE body seat on EPDM.
4. Butterfly made in AISI 316 (CF8M).
5. Stem made in AISI 316.
6. Actuator mounting plate according ISO 5211.
7. Face to face according UNE EN 558-1 Serie 20 (DIN 3202 K1).
8. Working Temperature $-25^{\circ}\text{C} + 180^{\circ}\text{C}$.

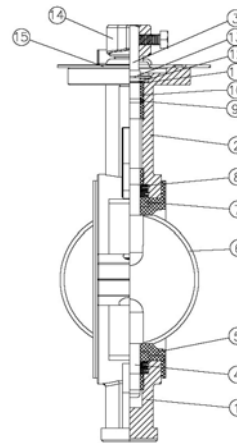

Nº	Denominación / Name	Material	Acabado Superficial/Surface Treatment
1	Cuerpo Inferior / Downside Body	Acero Inox. AISI 316 / SS 316	Granallado / Shot Blasting
2	Cuerpo Superior / Upside Body	Acero Inox. AISI 316 / SS 316	Granallado / Shot Blasting
3	Eje Superior / Upside Stem	Acero Inox. AISI 316 / SS 316	-----
4	Eje Inferior / Low Stem	Acero Inox. AISI 316 / SS 316	-----
5	Asiento / Seat	PTFE c/base EPDM / PTFE on EPDM	-----
6	Disco / Disc	Acero Inox. AISI 316 / SS 316	Granallado / Shot Blasting
7	Buje / Sleeve	RPTFE	-----
8	Arandelas Muelle / Spring washer	Acero Inox. AISI 301 / SS 301	-----
9	Tórica / O'ring	Viton	-----
10	Casquillo / Bush	RPTFE	-----
11	Arandela / Washer	Acero Inox. AISI 304 / SS 304	-----
12	Arandela Seeguer / Shapt Retainer	Acero Inox. AISI 304 / SS 304	-----
13	Arandela Seeguer / Ring Retainer	Acero Inox. AISI 304 / SS 304	-----
14	Maneta / Handle	Acero Inox. AISI 304 / SS 304	Pulido / Polished
15	Plato / Plate	Acero Inox. AISI 304 / SS 304	Pulido / Polished

DIMENSIONES GENERALES / GENERAL DIMENSIONS

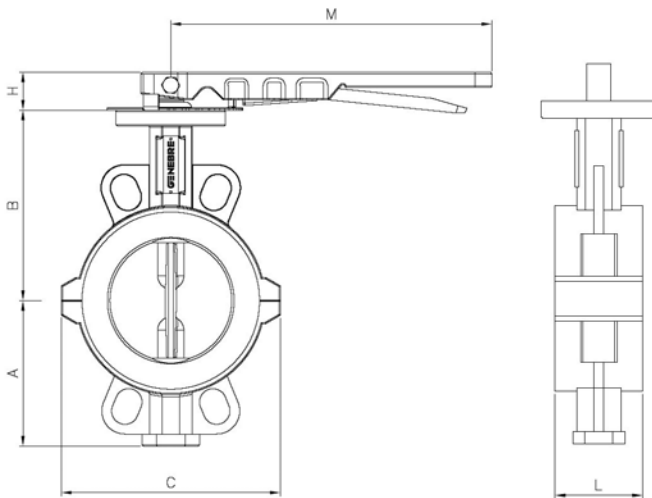

Ref	Medida/ Size	DN	PN	Dimensiones / Dimensions (mm)						Peso/ Weight (Kg)
				L	A	B	C	H	M	
2104 09	2"	50	16	43	74	136	117	32	264	3,800
2104 10	2 ½"	65	16	46	82	138	126	32	264	4,400
2104 11	3"	80	16	46	90	138	142	32	264	4,900
2104 12	4"	100	16	52	116	158	178	32	264	6,500
2104 13	5"	125	16	56	132	174	202	32	264	8,200
2104 14	6"	150	16	56	145	190	234	32	***	9,600
2104 16	8"	200	16	60	180	229	286	45	***	14,700

*** Nota: A partir de 6" (DN 150) operación mediante reductor manual.

*** Note: From 6" (DN 150) included , handling by gear operator.

Dimensiones de brida superior / Top flange dimensions:

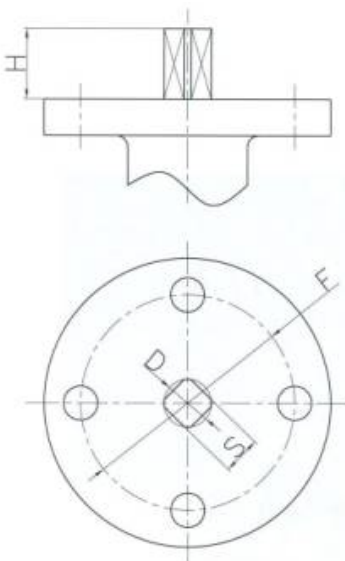

Dimensiones brida Superior / Top flange dimensions					
Ref.	F (5211)	S	D	H	Torque Nm.
2104 09	F05	11	14	32	20
2104 10	F05	11	14	32	25
2104 11	F05	11	14	32	30
2104 12	F07	14	18	32	60
2104 13	F07	14	18	32	100
2104 14	F07	14	18	32	180
2104 16	F10	17	22	45	300

Perdidas de Carga (Cv) según posición del disco / Head losses according disc position:

DN	Posición del Disco (grados) / Disc Position (degrees)								
	90°	80°	70°	60°	50°	40°	30°	20°	10°
50	144	114	84	61	43	27	16	7	1
65	282	223	163	107	67	43	24	11	1.5
80	461	364	267	154	96	61	35	15	2
100	841	701	496	274	171	109	62	27	3
125	1376	1146	775	428	268	170	98	43	5
150	1850	1542	1025	567	354	225	129	56	6
200	3316	2842	1862	1081	680	421	241	102	12

Medidas de Precaución para instalación / Precautions measures for Installation:

1. No instale la válvula en posición totalmente cerrada / *Do not assemble the butterfly valve in total closed position.*
2. Verifique el buen paralelismo de las bridas / *Check the good parallelism of the flanges.*
3. No coloque otras juntas entre las bridas / *Do not insert others gasket between flange and valve.*

