

WAFER BUTTERFLY VALVE FM (FIRE NETWORK)



- Size :** DN 50 to 300 mm
Ends : Between flanges GN10/16 and ISO PN20 ANSI150
Min Temperature : - 10°C
Max Temperature : + 90°C
Max Pressure : 16 Bars
Specifications : For fire network
Wafer type
Full crossing stem
Gear box with position indicator
- Materials :** Cast iron EN GJS-500-7 body

WAFER BUTTERFLY VALVE FM (FIRE NETWORK)

SPECIFICATIONS :

- F.M. : Factory mutual
- Long neck for isolation
- For fire network (F.M. approved)
- Gear box with position indicator
- Cast iron gear box
- Valve indicator (indicate valve position : opened or closed)
- Wafer type
- Between flanges GN10/16 and ISO PN20 ANSI150
- Full crossing stem
- Stainless steel disc up to DN100 included
- Rilsan coated body color RAL 5024 250-300 microns thickness

USE :

- For fire network
- Min and max Temperature Ts : - 10°C to + 90°C
- Max Pressure PN : 16 bars

RANGE :

- Wafer butterfly valve with gear box **Ref. 1144** DN 50 to DN 300

ENDS :

- Between flanges GN10-GN16 and ISO PN20 ANSI 150

TORQUE VALUE (in Nm with safety coefficient of 30 % included) :

DN	50	65	80	100	125	150	200	250	300
Torque (Nm)	11	20	29	47	82	130	210	360	475

FLOW COEFFICIENT Kv (m³ / h) :

DN	50	65	80	100	125	150	200	250	300
Kv (m ³ / h)	109	200	334	551	901	1427	2383	3825	5659

WAFER BUTTERFLY VALVE FM (FIRE NETWORK)

HEAD LOSS GRAPH :

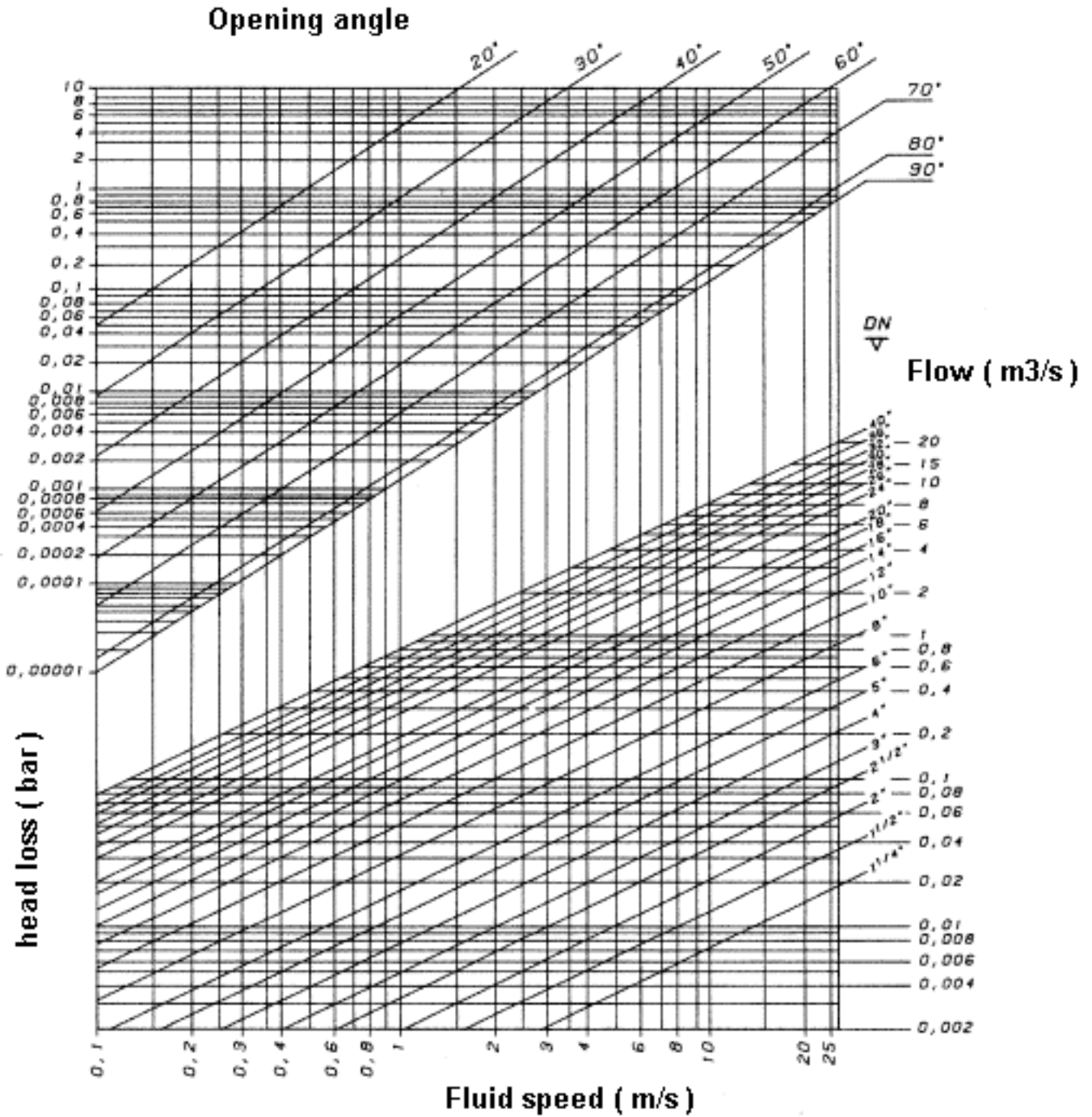

WAFER BUTTERFLY VALVE FM (FIRE NETWORK)

MATERIALS :

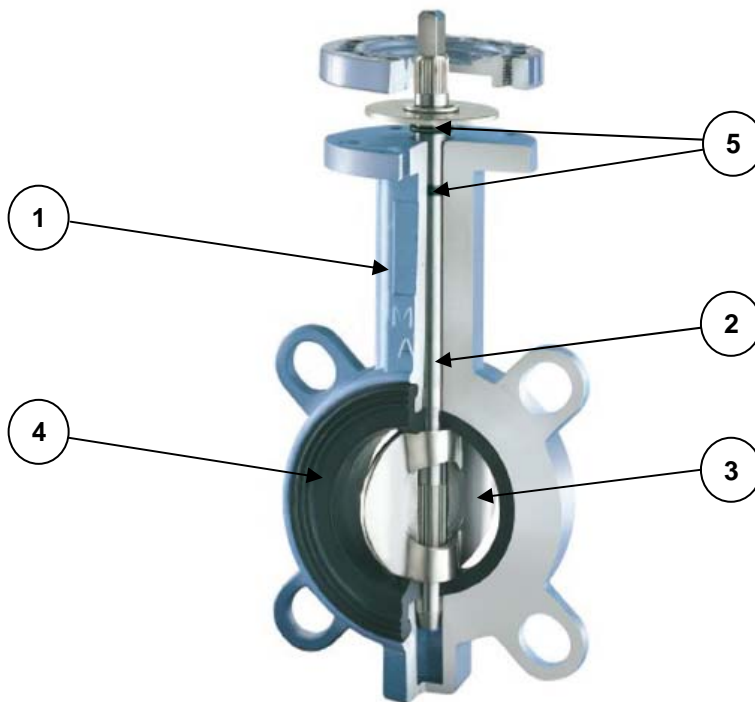

Item	Designation	Materials
1	Body	Cast iron EN GJS-500-7
2	Shaft	SS 420
3	Disc DN 50-100	SS 316
3	Disc DN125 - 300	Chromed Cast iron EN GJS-500-7
4	Seat	EPDM
5	O ring	NBR

WAFER BUTTERFLY VALVE FM (FIRE NETWORK)

SIZE GN10 (in mm) :

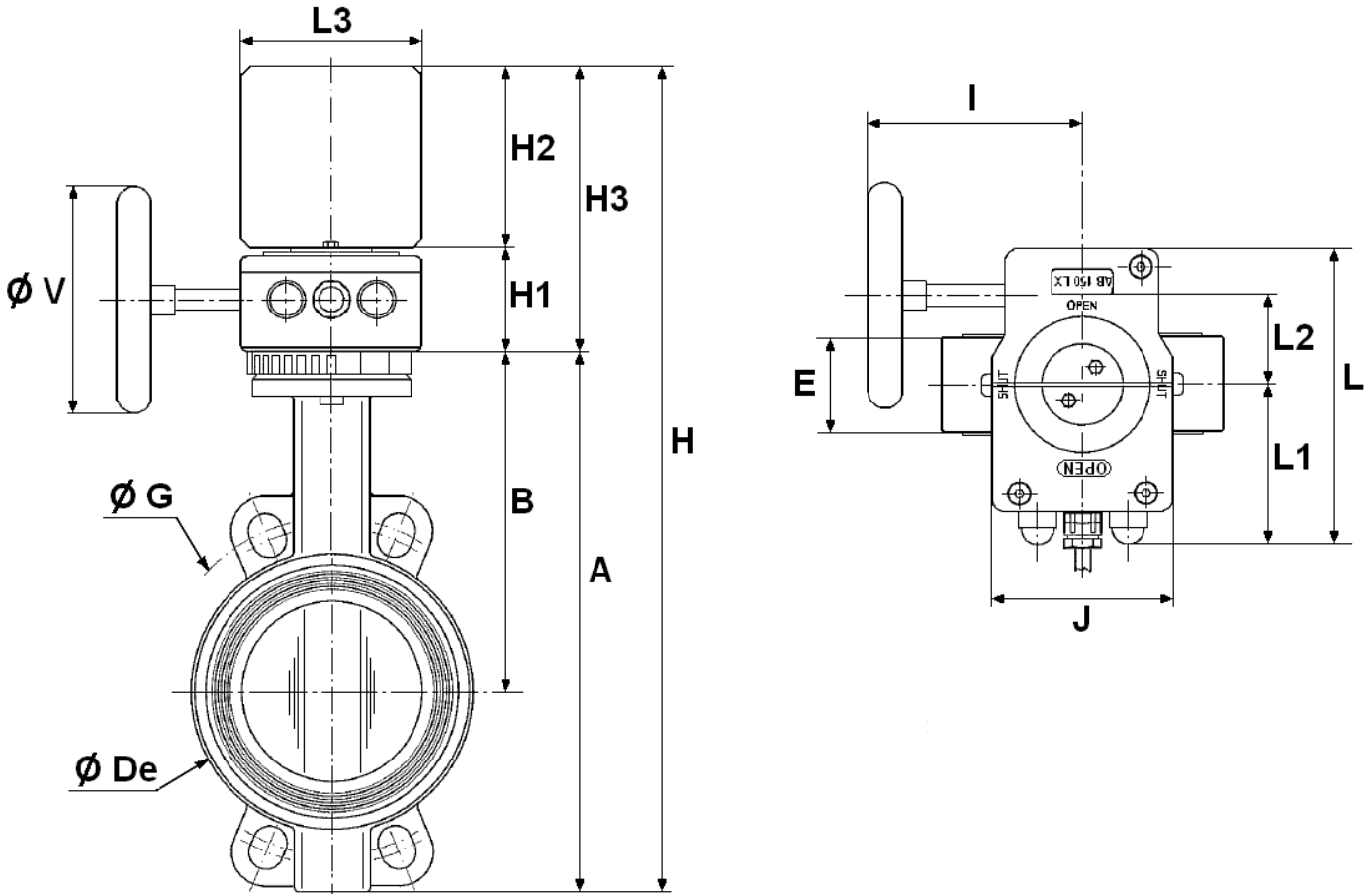

	DN	50	65	80	100	125	150	200	250	300
Ref. 1144	E	43	46	46	52	56	56	60	68	78
	A	227	243	266	294	324	349	438	461	523
	B	156	162	170	185	207	216	256	248	280
	H	329	345	363	397	417	439	551	585	663
	H1	48	48	48	48	54	54	78	78	84
	H2	54	54	54	54	37	37	46	46	56
	H3	102	102	102	102	91	91	124	124	140
	L3	55	55	55	55	46	46	75	75	86
	Ø V	100	100	100	100	250	250	250	250	315
	I	130	130	130	130	192	192	231	231	225
	J	80	80	80	80	102	102	130	130	154
	L	141	141	141	141	178	178	209	209	232
	L1	58	58	58	58	78	78	80	80	88
	L2	42	42	42	42	50	50	71	71	86
	Ø De	103	120	134	153	185	209	270	320	372
Ø G	125	145	160	180	210	240	295	350	400	
Weight (Kg)		5.9	6.7	7	8.45	12.5	13.85	24.8	34.8	48.45

WAFER BUTTERFLY VALVE FM (FIRE NETWORK)

POSITION INDICATOR :

- A double contact (incompleted opening position) , signal at the beginning of closure.
- 9 wires cable 0.75 mm² 1 meter long

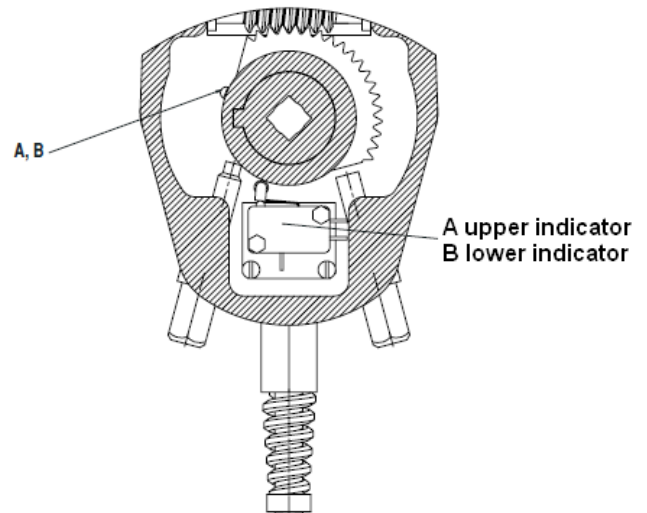
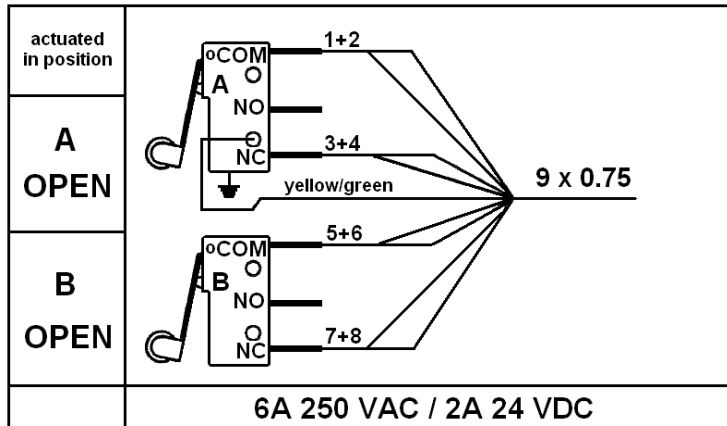

STANDARDS :

- Fabrication according to ISO 9001:2008
- DIRECTIVE 97/23/CE : CE N° 0409
Risk Category III module B + C1
- Designing according to NF EN 593 v 2004
- Marking according to NFE 29-130
- Tests according to EN 12266-1
- Between flanges according to EN 1092-1 ,EN 1092-2 and ANSI B16.5
- ISO 5211 mounting pad
- Length according to ISO 5752 NF 29205
- **FM** approved N°3025174 17/06/2008

WAFFER BUTTERFLY VALVE FM (FIRE NETWORK)

INSTALLATION INSTRUCTIONS

GENERAL GUIDELINES :

- Ensure that the valves to be used are appropriate for the conditions of the installation (type of fluid, pressure and temperature).
- Be sure to have enough valves to be able to isolate the sections of piping as well as the appropriate equipment for maintenance and repair.
- Ensure that the valves to be installed are of correct strength to be able to support the capacity of their usage.
- **Installation of all circuits should ensure that their function can be automatically tested on a regular basis (at least two times a year).**

INSTALLATION INSTRUCTIONS :

- **Before installing the valves, clean and remove any objects from the pipes** (in particular bits of sealing and metal) which could obstruct and block the valves.
- **Ensure that both connecting pipes either side of the valve (upstream and downstream) are aligned (if they're not, the valves may not work correctly).**
- **Make sure that the two sections of the pipe (upstream and downstream) match, the valve unit will not absorb any gaps. Any distortions in the pipes may affect the tightness of the connection, the working of the valve and can even cause a rupture.** To be sure, place the kit in position to ensure the assembling will work.
- **If sections of piping do not have their final support in place, they should be temporarily fixed. This is to avoid unnecessary strain on the valve.**
- The valve must be inserted between flanges with disc half opened but the disc must not overpass the valve thickness. Position the bolts to keep centered the valve. Then open fully the valve and tighten the bolts. **See graph under.**

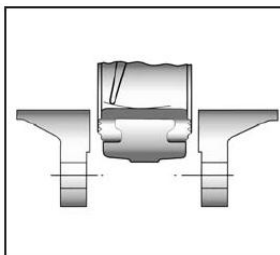

Half open valve introduction

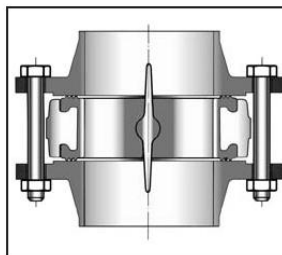

Complete opened disc valves
when screw tightening

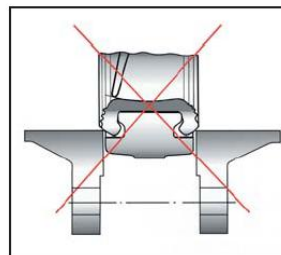

- Tighten the bolts in cross.
- The disc must move easily inside the pipe.
- Valves must be opened during cleaning operation.
- Tests must be done with a cleaned pipe.
- Tests must be done with opened valve. Test pressure must not be higher than the valve specification according to EN 12266-1.
- Then open slowly the valve.
- **Do not mount butterfly valves with stainless steel pressed collars and turning flanges without strias.**
- **And not on flat face flanges without strias (example : painted cast iron fittings)**

WAFER BUTTERFLY VALVE FM (FIRE NETWORK)**MAINTENANCE :**

- We recommend to operate fully the valve 1 to 2 times per year.
- During maintenance operation, ensure that the pipe isn't under pressure, that there's no fluid in the pipe and that the valve is isolated. If there's a fluid in the pipe , evacuate it. Ensure that there are no risks due to the temperature or the fluid (like acids). If the fluid is corrosive , inert the installation before maintenance operation.

ADVICE : Our opinion and our advice are not guaranteed and SFERACO shall not be liable for the consequences of damages. The customer must check the right choice of the products with the real service conditions.