

**WAFER BUTTERFLY VALVE PN10**



**Size :** DN 40 to 300 mm  
**Ends :** Between flanges GN10/16 and ASA150  
**Min Temperature :** - 10°C  
**Max Temperature :** + 90°C ( temporarily 110°C )  
**Max Pressure :** 10 Bars  
**Specifications :** Long neck for isolation  
Wafer type  
Full crossing stem  
Iso 5211 mounting pad

**Materials :** Cast iron EN GJL 250 body

## WAFER BUTTERFLY VALVE PN10

### SPECIFICATIONS :

- Long neck for isolation
- ISO 5211 mounting pad
- Wafer type
- Between flanges GN10/16 and ASA150
- Full crossing stem
- Removable seat
- Chromed cast iron disc
- 9 positions lever, with locking device up to DN200 , stop in all positions but non lockable from DN250 to 300
- Epoxy painting RAL 5012 color 250-300 microns thickness
- Stem extension 75 mm length ( option )
- Square lever 30x30 mm for special key ( option )

### USE :

- Water distribution
- Min and max Temperature Ts : -10°C to + 90°C ( Temporarily 110°C )
- Max Pressure Ps : 10 bars
- $\Delta P$  : 6 bars max

### RANGE :

- With lever from DN 40 to DN 300
- Gear box possible ( **Ref. 1197** ) from DN 40 to DN 300
- On request, chain gear box possible ( **Ref. 98662** ) from DN 40 to DN 300
- On request, stem extension with special length ( **Ref. 98665** )

### ENDS :

- Between flanges GN10-GN16 and ASA 150

### TORQUE VALUES ( in Nm with safety coefficient of 30 % included ) at 10 Bars :

DN	40	50	65	80	100	125	150	200	250	300
Torque ( Nm )	9	11	20	29	47	82	130	210	360	475

### FLOW COEFFICIENT Kv ( m<sup>3</sup> / h ) :

DN	40	50	65	80	100	125	150	200	250	300
Kv ( m <sup>3</sup> /h )	70	109	200	334	551	901	1427	2383	3825	5659

**WAFER BUTTERFLY VALVE PN10**

HEAD LOSS GRAPH :

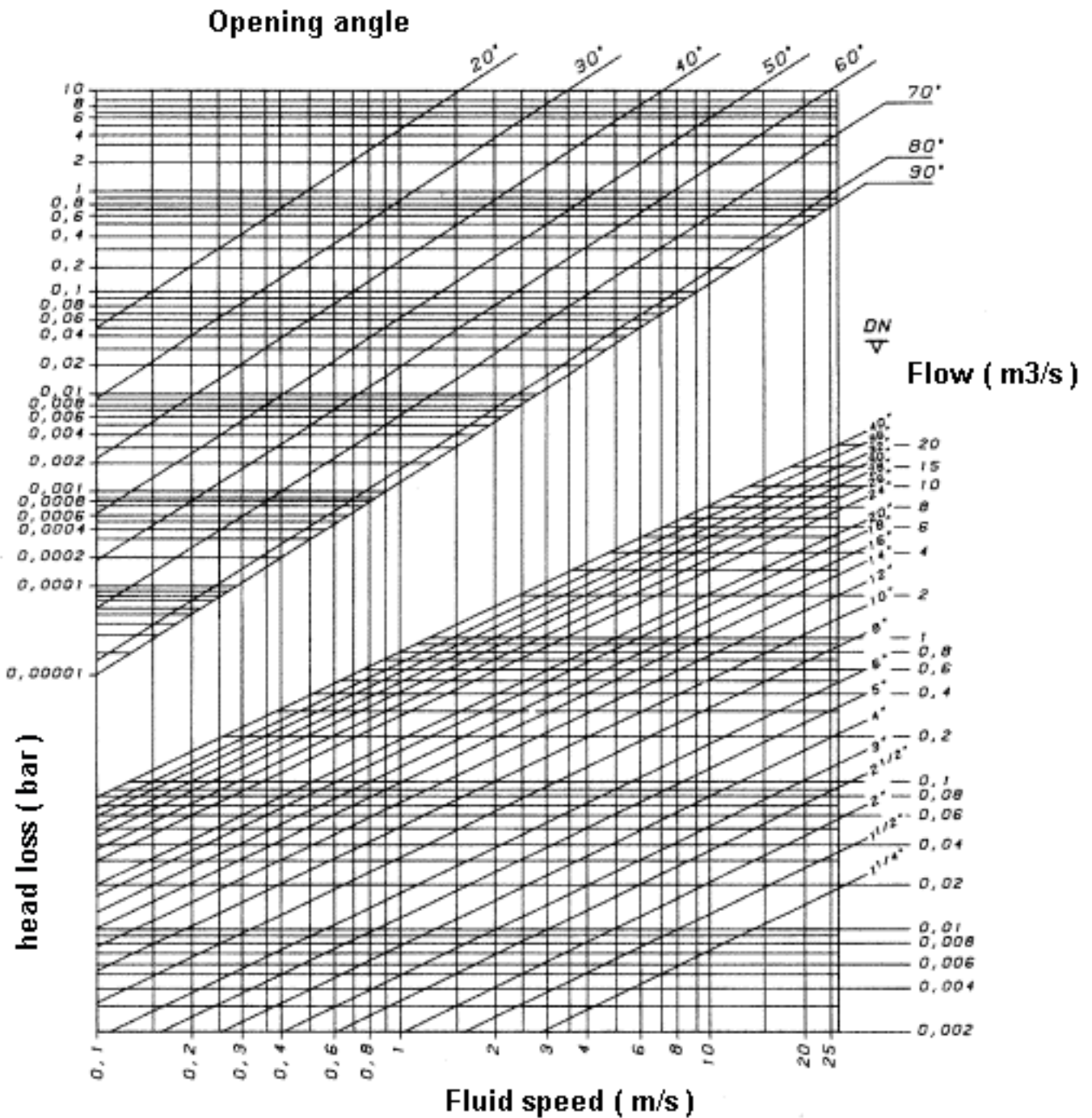

**WAFER BUTTERFLY VALVE PN10**

MATERIALS DN 40 - 200 :

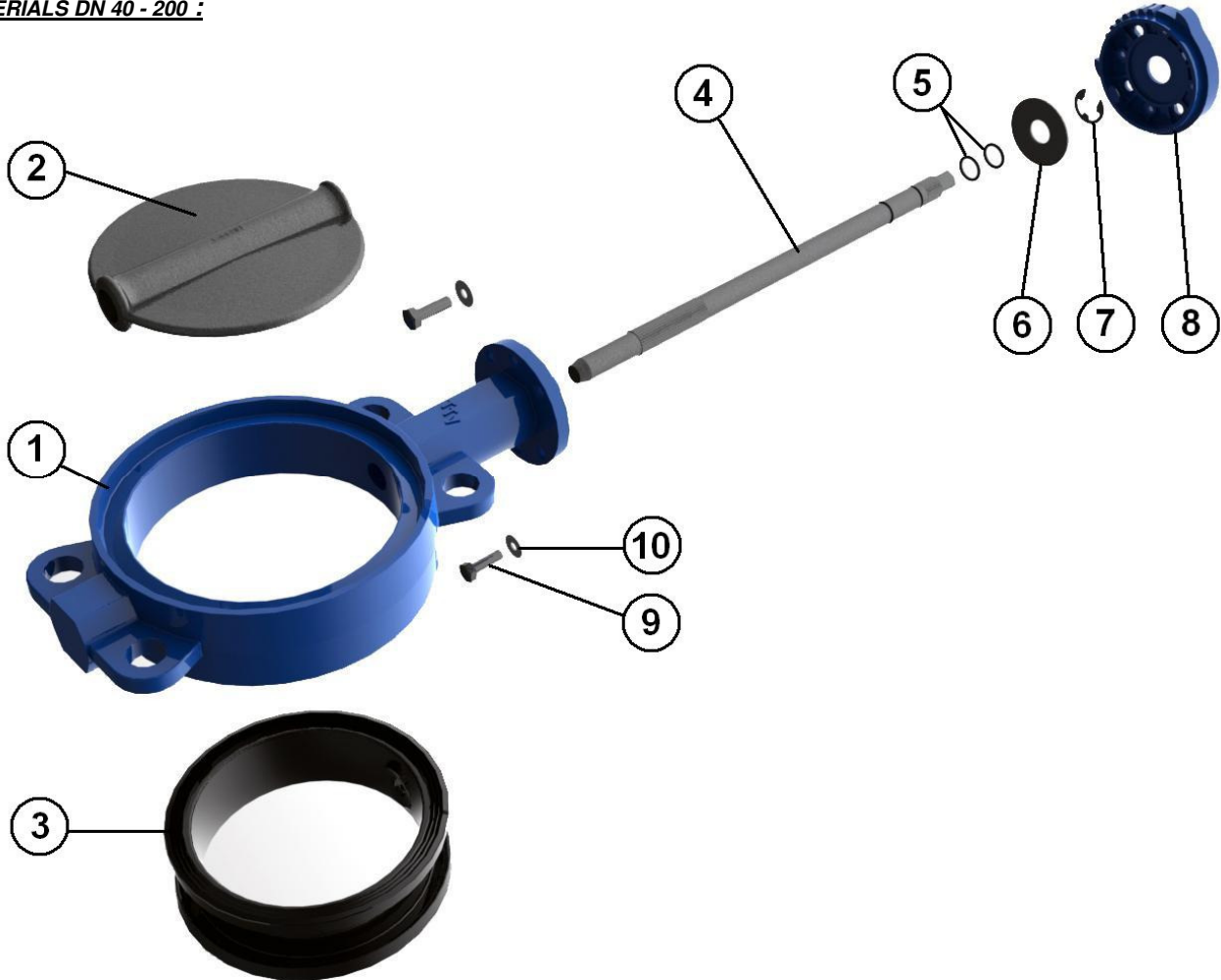

Item	Designation	Materials
1	Body	Cast iron EN GJL 250
2	Disc	EN GJS 500-7 chromed
3	Elastic ring	EPDM
4	Stem	SS 420
5	O ring	EPDM
6	Ring	Steel
7	Circlips	Steel
8	Plate	Aluminium
9	Plate screw	5.6
10	Washer	Steel
	Lever	Aluminium

**WAFER BUTTERFLY VALVE PN10**

**MATERIALS DN 250 - 300 :**

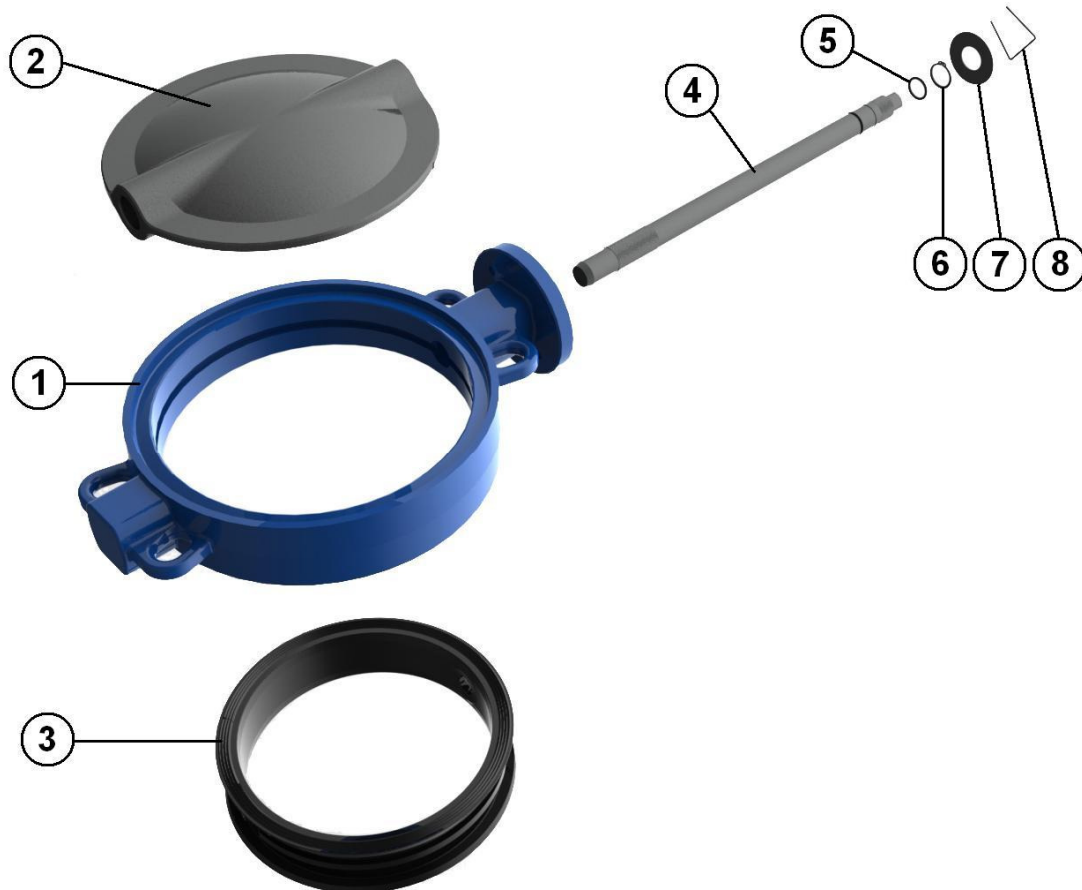

Item	Designation	Materials
1	Body	Cast iron EN GJL 250
2	Disc	EN GJS 500-7 chromed
3	Elastic ring	EPDM
4	Stem	SS 420
5	O ring	EPDM
6	Circlips	Steel
7	Ring	Steel
8	Spring	Steel
	Lever	Aluminium

**WAFER BUTTERFLY VALVE PN10**

**SIZE GN10 ( in mm ) :**

- Valves DN 40 - 300 :

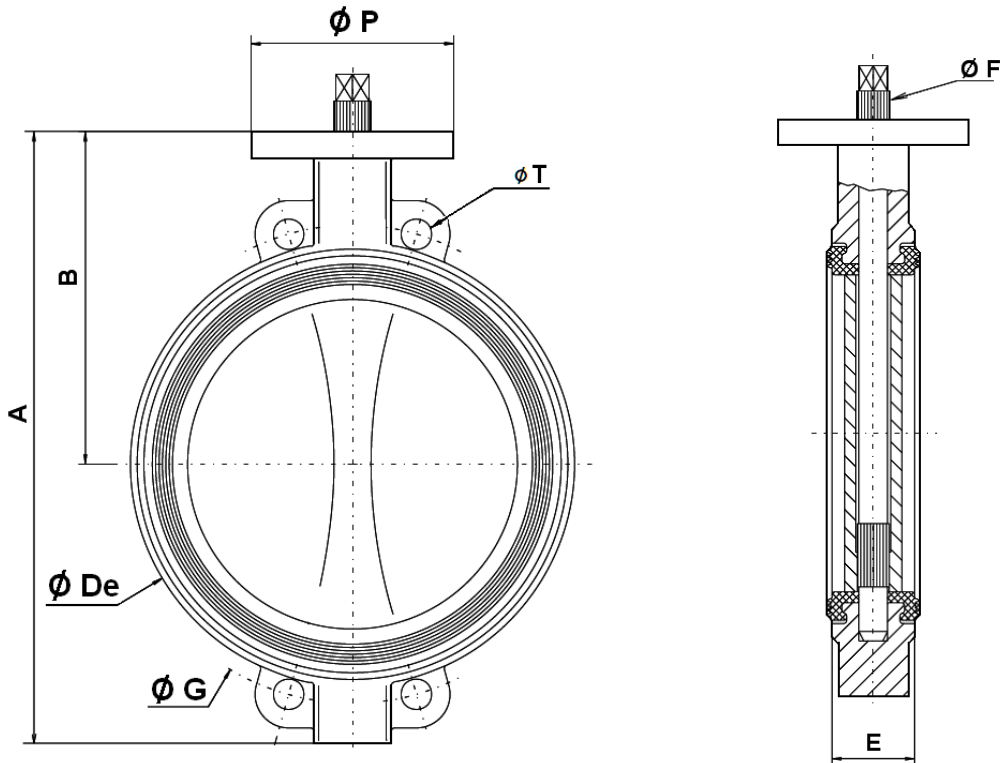

DN	40	50	65	80	100	125	150	200	250	300
A	206	228	243	266	294	324	349	438	461	523
B	140	156	162	170	185	207	216	256	248	280
Ø De	82	102	119	135	155	185	208	270	328	381
E	33	43	46	46	52	56	56	60	68	78
Ø F	10.5	10.5	14.5	16.5	16.5	18.5	18.5	22.5	25.5	30.5
Ø G	110	125	145	160	180	210	240	295	350	400
Ø P	88	88	88	88	88	105	105	105	150	150
Ø T	18	18	18	18	18	18	23	23	23	23
Weight (Kg)	2.6	3.6	4.55	4.8	6.06	7.6	9	13.94	23.07	32

- Levers :

DN 40 – 100

DN 125 – 200

DN 250 - 300

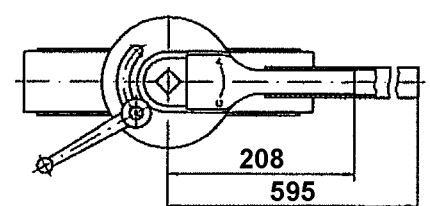
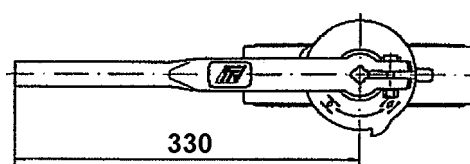
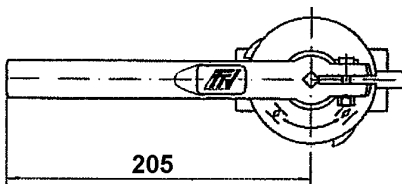

## WAFER BUTTERFLY VALVE PN10

**SIZE GN10 ( in mm ) :**

- Valves with gear box DN 40 - 300 :

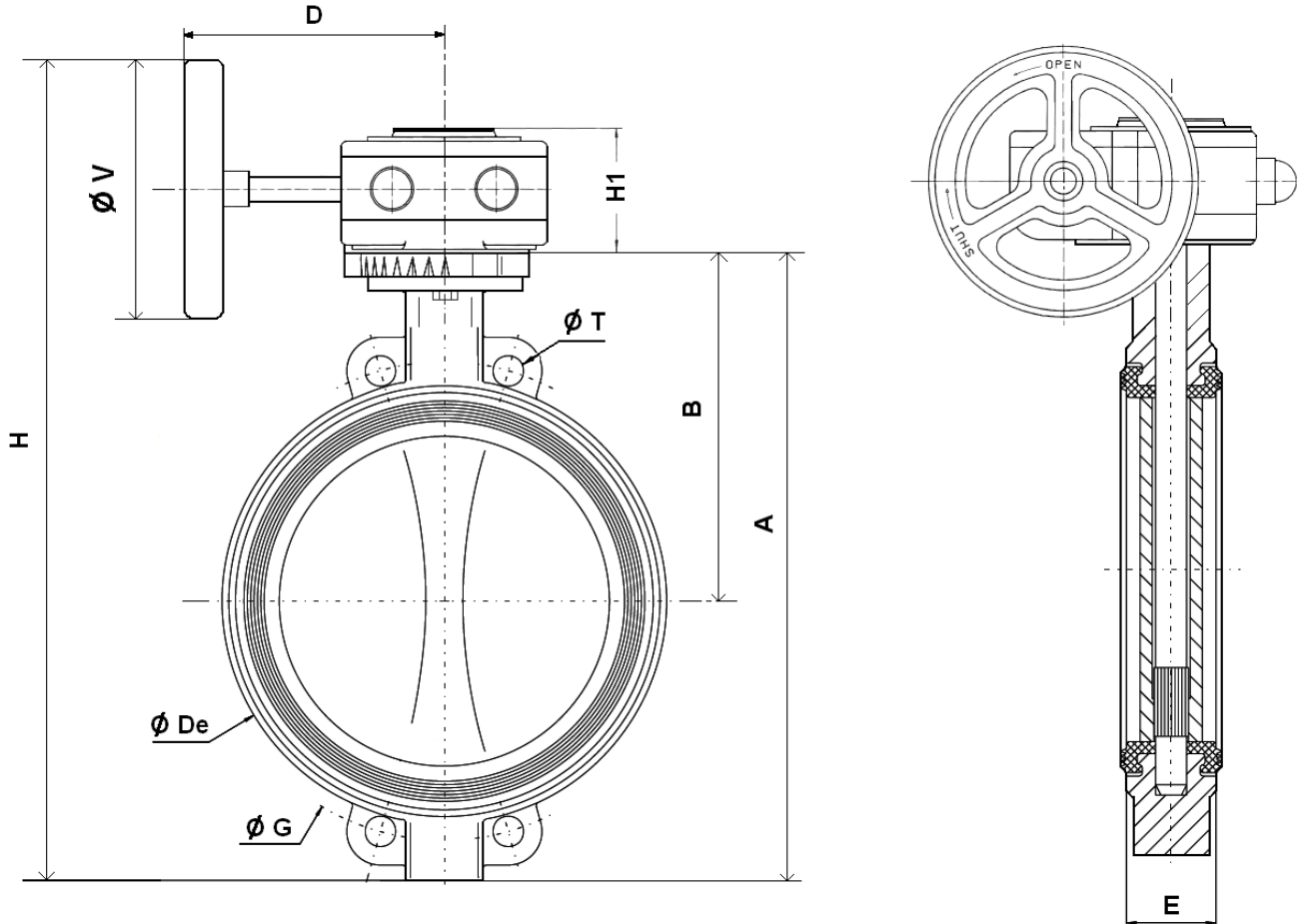

DN	40	50	65	80	100	125	150	200	250	300
A	206	228	243	266	294	324	349	438	461	523
B	140	156	162	170	185	207	216	256	248	280
Ø De	82	102	119	135	155	185	208	270	328	381
D	120	120	120	120	120	136	136	136	223	223
E	33	43	46	46	52	56	56	60	68	78
H	304	326	341	364	392	452	477	566	647	709
H1	58	58	58	58	58	58	58	58	74	74
Ø G	110	125	145	160	180	210	240	295	350	400
Ø T	18	18	18	18	18	18	23	23	23	23
Ø V	140	140	140	140	140	200	200	200	300	300
Weight ( Kg )	3.95	4.95	5.9	6.15	7.41	9.35	10.75	15.69	27.07	36

**WAFER BUTTERFLY VALVE PN10**

**SIZE GN10 ( in mm ) :**

- **Valves with chain gear box :**

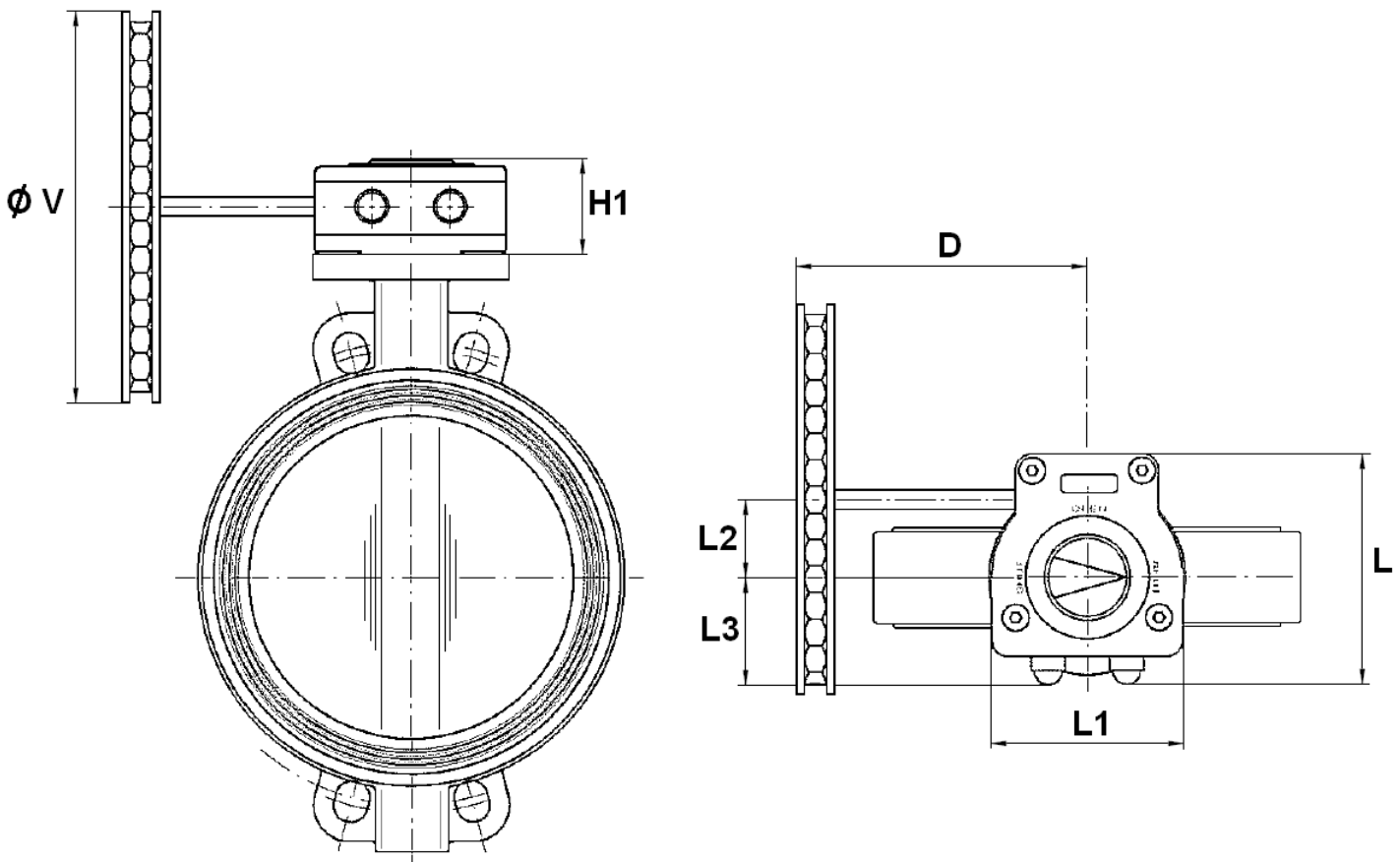

DN	40	50	65	80	100	125	150	200	250	300
D	120	120	120	120	120	126	126	126	214	214
H1	58	58	58	58	58	58	58	58	77	77
L	130	130	130	130	130	130	130	130	177.5	177.5
L1	100	100	100	100	100	100	100	100	146	146
L2	50	50	50	50	50	50	50	50	60	60
L3	58	58	58	58	58	58	58	58	82.5	82.5
Ø V	125	125	125	125	125	210	210	200	300	300
Weight ( Kg )	4.95	5.95	6.9	7.15	8.41	10.35	11.75	16.69	29.87	38.8



## WAFER BUTTERFLY VALVE PN10

**SIZE GN10 ( in mm ) :**

- **Stem extension for isolation ( 75 mm ) :**

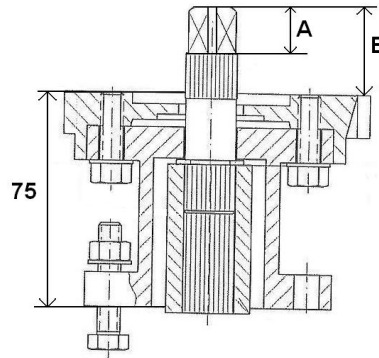
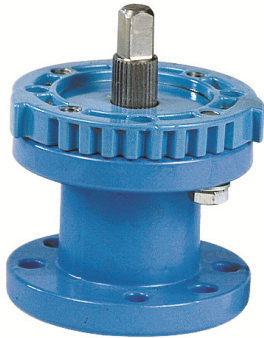

DN	40-50	65	80-100	125-150	200
A	19	19	19	17	17
B	34	34	34	34	34
Weight (Kg)	0.8	0.8	0.9	0.9	1

- **Square lever for special key ( 30x30 mm ) :**

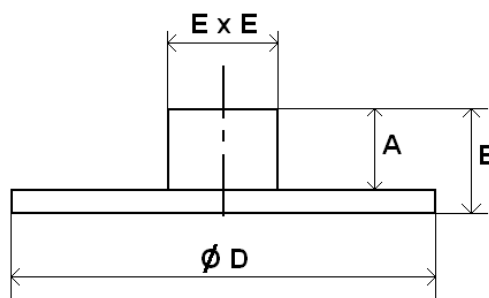

DN	40-50	65	80-100	125-150	200
A	20	20	20	20	20
B	31	31	32	32	32
Ø D	107	107	107	107	107
E x E	30 x 30	30 x 30	30 x 30	30 x 30	30 x 30
Weight (Kg)	0.88	0.88	0.88	0.88	0.88

**WAFER BUTTERFLY VALVE PN10**

**ISO MOUNTING PAD AND STEM SIZE ( in mm ) :**

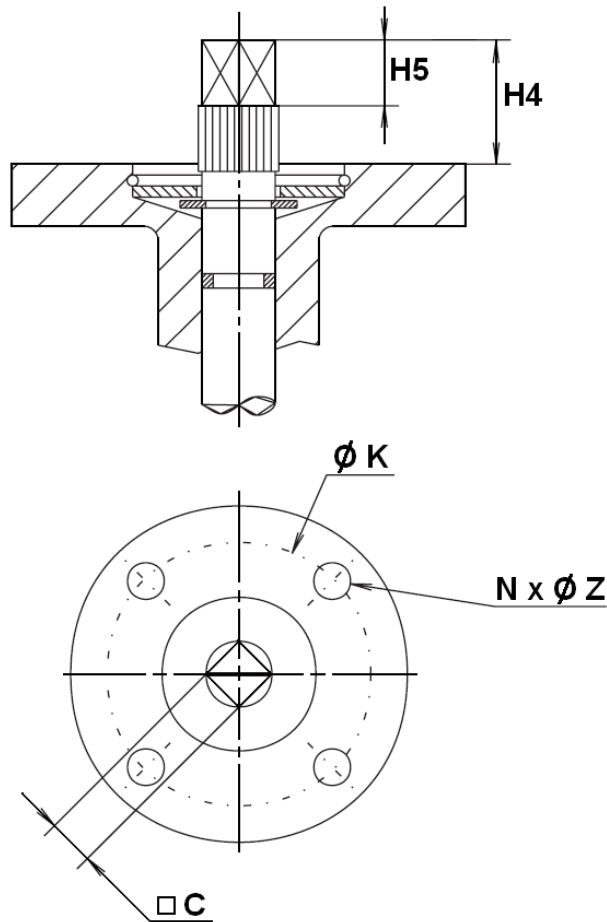

DN	40	50	65	80	100	125	150	200	250	300
H4	30	30	30	30	30	30	30	30	40	40
H5	17	17	17	17	17	17	17	17	20	20
C	8	8	9	11	11	14	14	17	19	22
Ø K	70	70	70	70	70	70	70	70	102	102
ISO	F07	F07	F07	F07	F07	F07	F07	F07	F10	F10
N x Ø Z	4 x 9	4 x 9	4 x 9	4 x 9	4 x 9	4 x 9	4 x 9	4 x 9	4 x 11	4 x 11

## WAFER BUTTERFLY VALVE PN10

### STANDARDS :

- Fabrication according to ISO 9001:2008
- DIRECTIVE 97/23/CE : CE N° 0409  
Risk Category I module A
- Tests according to ISO 5208
- Between flanges according to EN 1092-1 PN10
- ISO 5211 mounting pad
- Length according to ISO 5752 short series 20 , BS 5155 Wafer short/medium series, DIN 3202 part 3, series K1

**ADVICE :** Our opinion and our advice are not guaranteed and SFERACO shall not be liable for the consequences of damages. The customer must check the right choice of the products with the real service conditions.

## INSTALLATION INSTRUCTIONS

### GENERAL GUIDELINES :

- Ensure that the valves to be used are appropriate for the conditions of the installation (type of fluid, pressure and temperature).
- Be sure to have enough valves to be able to isolate the sections of piping as well as the appropriate equipment for maintenance and repair.
- Ensure that the valves to be installed are of correct strength to be able to support the capacity of their usage.
- **Installation of all circuits should ensure that their function can be automatically tested on a regular basis (at least two times a year).**

### INSTALLATION INSTRUCTIONS :

- **Before installing the valves, clean and remove any objects from the pipes** (in particular bits of sealing and metal) which could obstruct and block the valves.
- **Ensure that both connecting pipes either side of the valve (upstream and downstream) are aligned (if they're not, the valves may not work correctly).**
- **Make sure that the two sections of the pipe (upstream and downstream) match, the valve unit will not absorb any gaps. Any distortions in the pipes may affect the tightness of the connection, the working of the valve and can even cause a rupture.** To be sure, place the kit in position to ensure the assembling will work.

## WAFER BUTTERFLY VALVE PN10

### INSTALLATION INSTRUCTIONS ( SUITE ):

- If sections of piping do not have their final support in place, they should be temporarily fixed. This is to avoid unnecessary strain on the valve.
- The valve must be inserted between flanges with disc half opened but the disc must not overpass the valve thickness. Position the bolts to keep centered the valve. Then open fully the valve and tighten the bolts. See graph under.

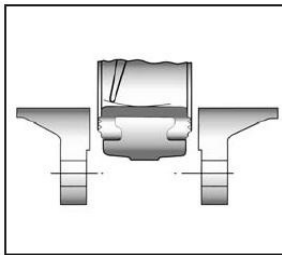

Half open valve introduction

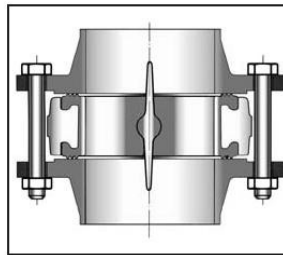

Complete opened disc valves when screw tightening

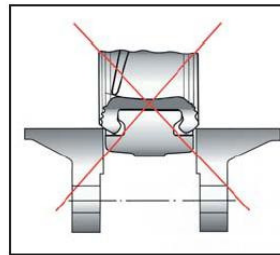

- Tighten the bolts in cross.
- The disc must move easily inside the pipe.
- Valves must be opened during cleaning operation.
- Tests must be done with a cleaned pipe.
- Tests must be done with opened valve. Test pressure must not be higher than the valve specification according to EN 12266-1.
- Then open slowly the valve.
- **Do not mount butterfly valves with stainless steel pressed collars and turning flanges.**
- **And not on flat face flanges without strias ( example : painted cast iron fittings )**

### MAINTENANCE :

- We recommend to operate fully the valve 1 to 2 times per year.
- During maintenance operation, ensure that the pipe isn't under pressure, that there's no fluid in the pipe and that the valve is isolated. If there's a fluid in the pipe , evacuate it. Ensure that there are no risks due to the temperature or the fluid ( like acids ). If the fluid is corrosive , inert the installation before maintenance operation.