

METAL/METAL WAFER BUTTERFLY VALVE (NO TIGHTNESS)



Size : DN 40 to 1400 mm
Ends : Between flanges GN10/16 and ISO PN20 ANSI150
Min Temperature : - 20°C for carbon steel and -30°C for S.S. type
Max Temperature : + 350°C
Max Pressure : 16 Bars up to DN200
Specifications : Long neck for isolation
Wafer type
Crossing stem
ISO 5211 mounting pad

Materials : Carbon or stainless steel body

METAL/METAL WAFER BUTTERFLY VALVE (NO TIGHTNESS)
SPECIFICATIONS :

- Long neck for isolation
- ISO 5211 mounting pad
- Wafer type
- Between flanges GN10/16 and ISO PN20 ANSI150 up to DN400 included (over on request)
- Between flanges GN10 from DN450 to DN1400
- Crossing stem
- **No tightness , loss factor : 2% of Kvs**
- Stainless steel disc up to DN100 included
- 9 positions lever, with locking device up to DN200 , stop in all positions but non lockable from DN250 to 300
- Stem extension 75 mm length (option)
- Square lever 30x30 mm for special key (option)

USE :

- For all common fluids
- Min and max Temperature Ts : - 20°C to + 350°C for carbon steel type **Ref.1111**
- Min and max Temperature Ts : - 30°C to + 350°C* for stainless steel type **Ref.1112**
 (* : higher temperature on request)
- Max Pressure PN : 16 bars up to DN200 , 10 bars over
- **Not for steam**

RANGE :

- With lever from DN 40 to DN 300
- Naked stem from DN 350 to DN1400
- Gear box possible (**Ref. 1197**) from DN 40 to DN 1400
- On request, chain gear box (**Ref. 98662**) from DN 40 to DN 500
- On request, stem extension with special length (**Ref. 98665**)

ENDS :

- Between flanges GN10-GN16 and ISO PN20 ANSI 150 up to DN400
- Between flanges GN10 from DN450 to DN 1400

TORQUE VALUES (in Nm without safety coefficient) at 10 Bars :

DN	40	50	65	80	100	125	150	200	250	300	350	400
Torque (Nm)	5	5	10	15	25	45	60	80	110	120	140	160

DN	450	500	600	700	750	800	900	1000	1100	1200	1300	1400
Torque (Nm)	250	300	450	950	1050	1100	1150	1200	1300	1800	1900	2000

FLOW COEFFICIENT Kv (m³ / h) :

DN	40	50	65	80	100	125	150	200	250	300	350	400
Kv (m ³ /h)	70	109	200	334	551	901	1427	2383	3825	5659	8177	10659

DN	450	500	600	700	800	900	1000	1200	1300	1400
Kv (m ³ /h)	12562	16021	22737	32443	43263	53873	64407	97341	119770	129808

METAL/METAL WAFER BUTTERFLY VALVE (NO TIGHTNESS)

HEAD LOSS GRAPH :

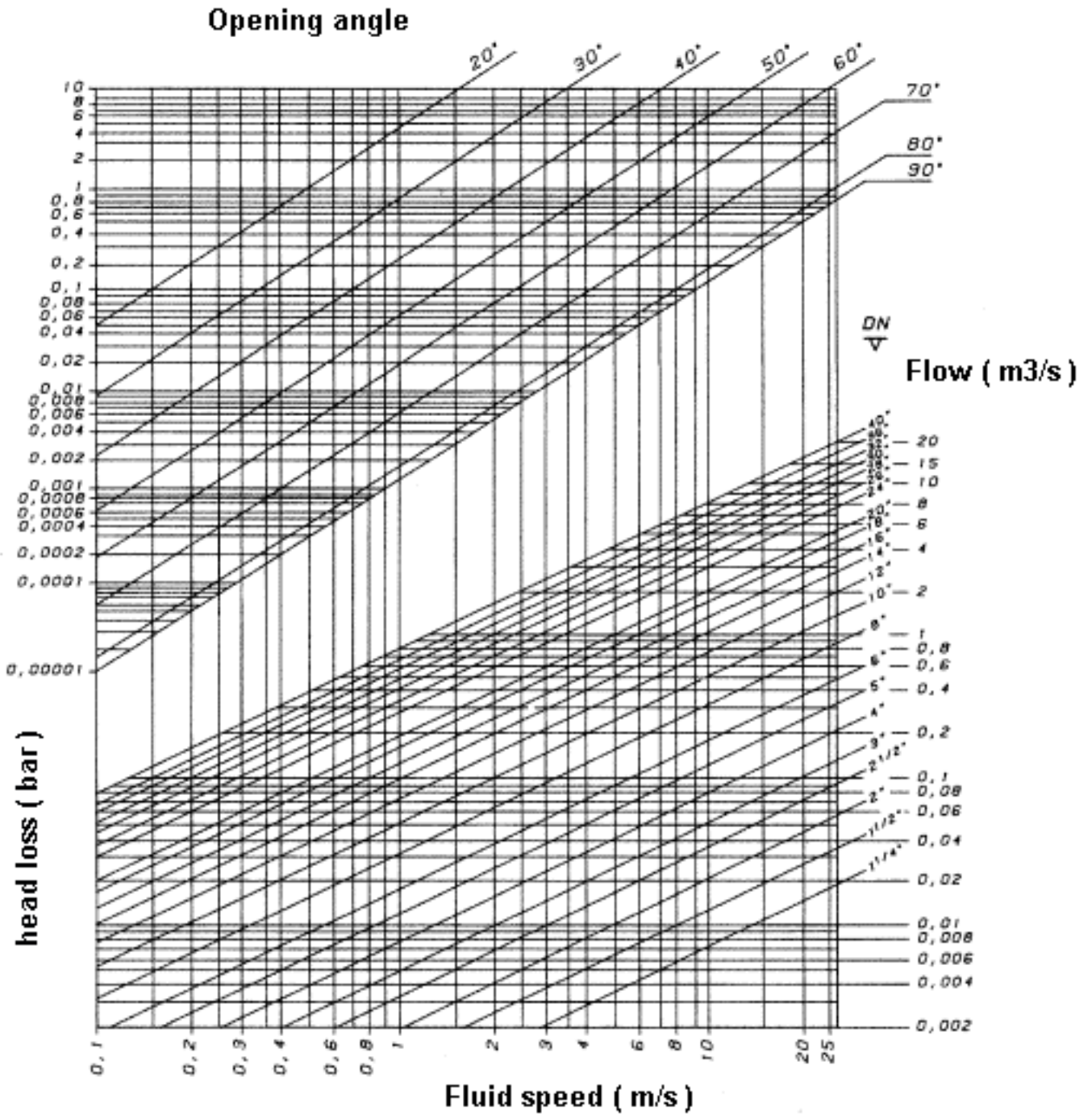

METAL/METAL WAFER BUTTERFLY VALVE (NO TIGHTNESS)

MATERIALS DN 40 - 200 :

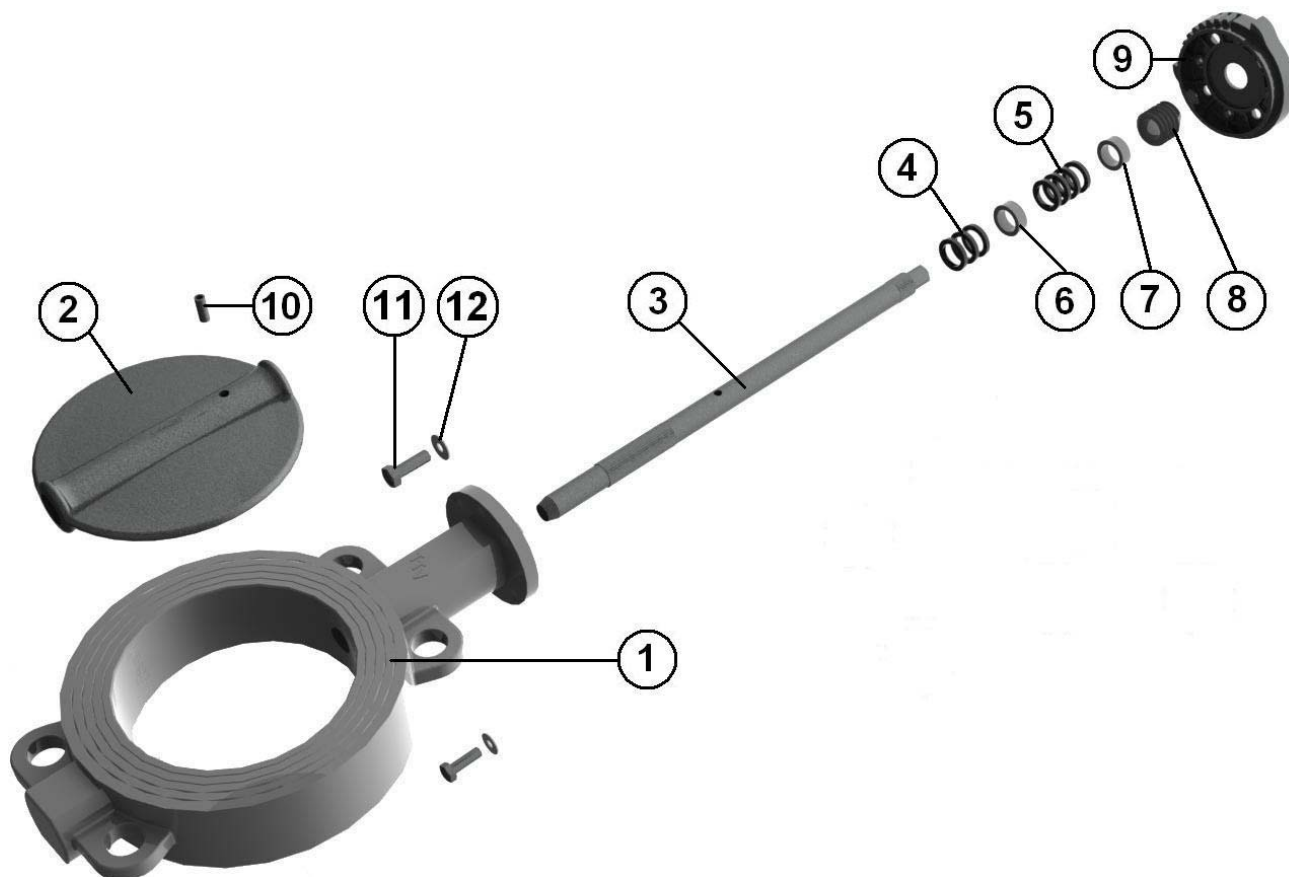

Item	Designation	Materials	
		1111	1112
1	Body	A216 WCB	SS 316
2	Disc DN40-100	SS 316	SS 316
2	Disc DN125-200	EN GJS 500-7	SS 316
3	Stem	SS 420	SS 316
4	Gasket	FILAM. GRAPHITE	FILAM. GRAPHITE
5	Gasket	FILAM. GRAPHITE	FILAM. GRAPHITE
6	Ring	BRONZE	SS 316
7	Ring	BRONZE	SS 316
8	Socket	5.6	SS 316
9	Plate	ALUMINIUM	CF-8M
10	Pin	ST-34	SS 316
11	Screw	5.6	A4
12	Washer	Steel	SS 316
	Lever	Aluminium	

METAL/METAL WAFER BUTTERFLY VALVE (NO TIGHTNESS)

MATERIALS DN 250 - 400 :

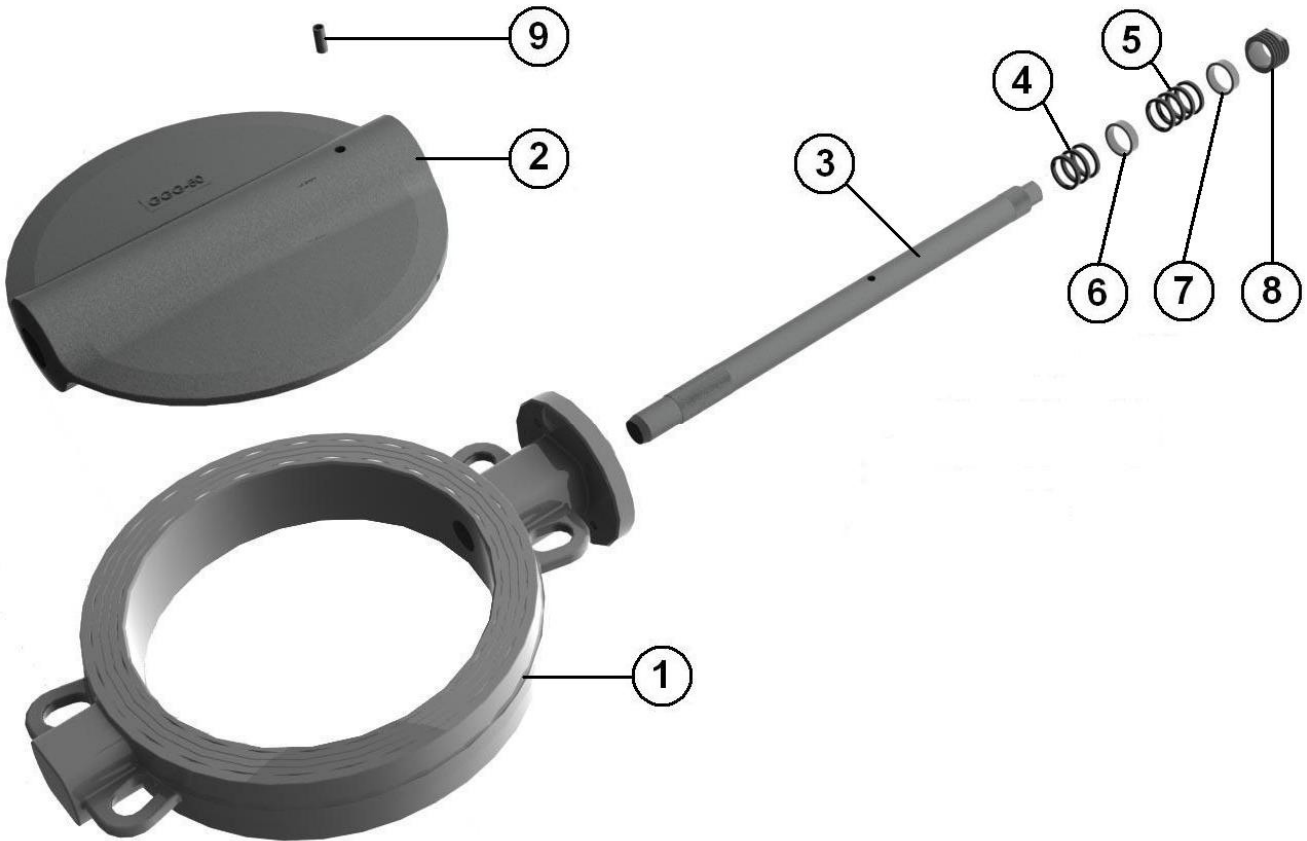

Item	Designation	Materials	
		1111	1112
1	Body	A216 WCB	SS 316
2	Disc	EN GJS 500-7	SS 316
3	Stem	SS 420	SS 316
4	Gasket	FILAM. GRAPHITE	FILAM. GRAPHITE
5	Gasket	FILAM. GRAPHITE	FILAM. GRAPHITE
6	Ring	BRONZE	SS 316
7	Ring	BRONZE	SS 316
8	Socket	5.6	SS 316
9	Pin	ST-34	SS 316
Lever (up to DN300)		Aluminium	

METAL/METAL WAFER BUTTERFLY VALVE (NO TIGHTNESS)

MATERIALS DN 450 - 1400 :

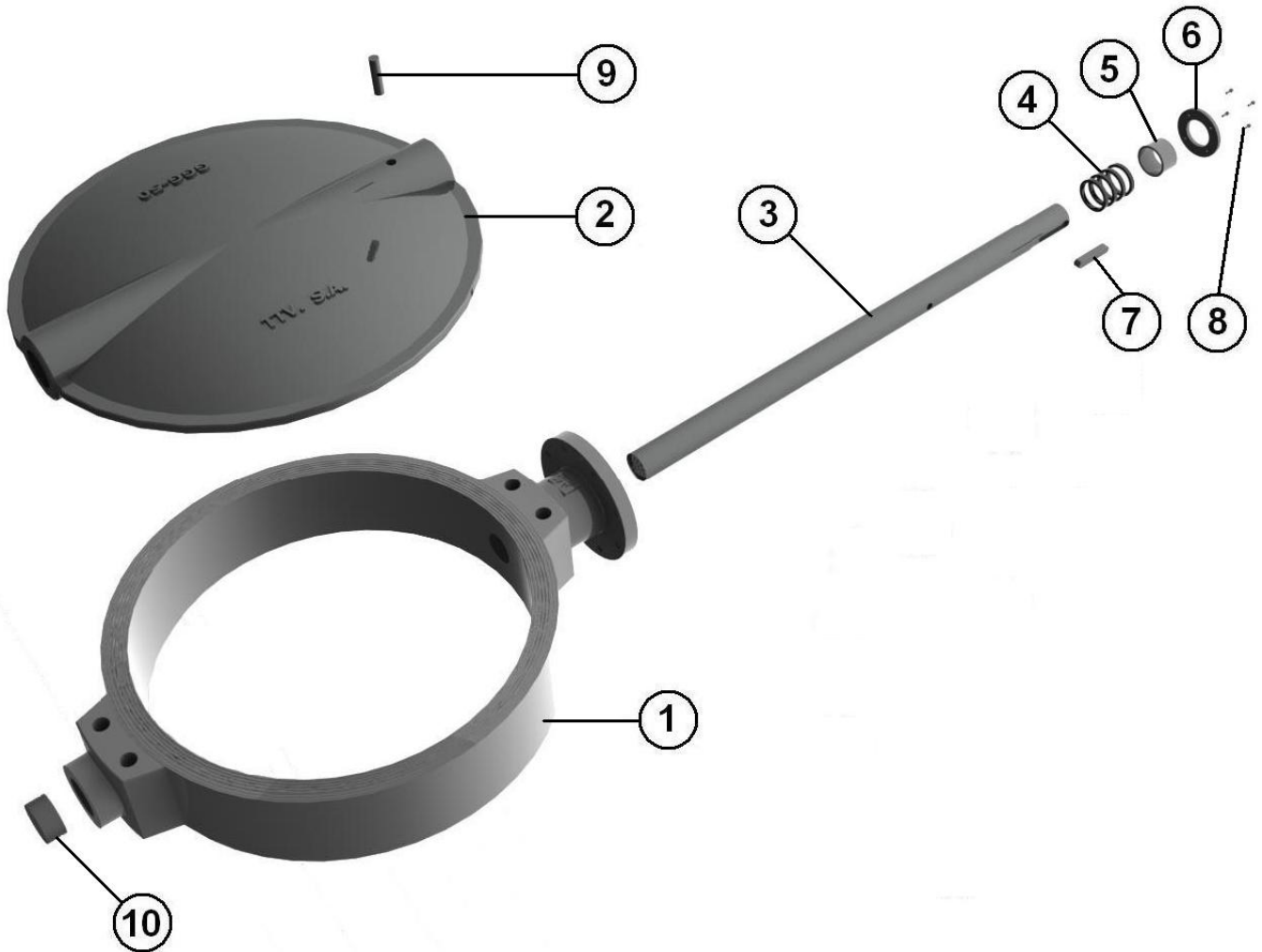

Item	Designation	Materials	
		1111	1112
1	Body	A216 WCB	SS 316
2	Disc	EN GJS 500-7	SS 316
3	Stem	SS 420	SS 316
4	Gasket	FILAM. GRAPHITE	FILAM. GRAPHITE
5	Ring	BRONZE	SS 316
6	Ring	BRONZE	SS 316
7	Pin	SS 420	SS 316
8	Screw	5.6	SS 316
9	Pin	ST-34	SS 316
10	Ring	A216 WCB	SS 316

METAL/METAL WAFER BUTTERFLY VALVE (NO TIGHTNESS)

SIZE GN10 (in mm) :

- Valves DN 40 - 400 :

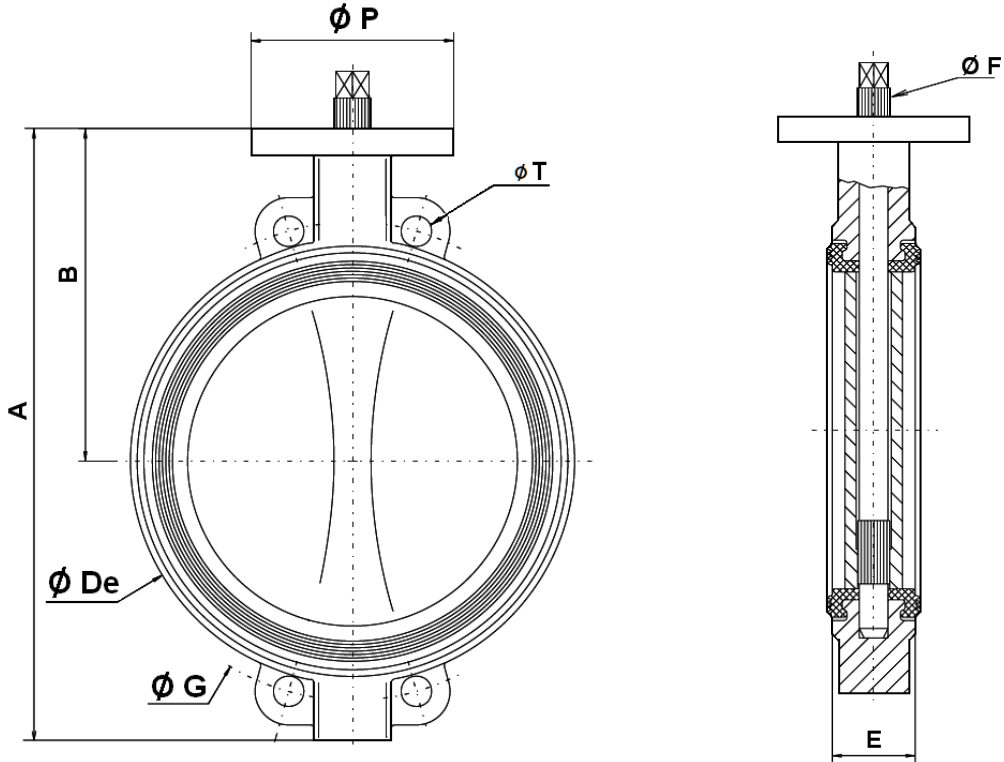

Ref.	DN	40	50	65	80	100	125	150	200	250	300	350	400
1111 1112	A	206	228	243	266	294	324	349	438	461	523	582	645
	B	140	156	162	170	185	207	216	256	248	280	300	340
	Ø De	82	102	119	135	155	185	208	270	328	381	437	486
	E	33	43	46	46	52	56	56	60	68	78	78	102
	Ø F	10.5	10.5	14.5	16.5	16.5	18.5	18.5	22.5	25.5	30.5	30.5	35.5
	Ø G	110	125	145	160	180	210	240	295	350	400	460	515
	Ø P	88	88	88	88	88	105	105	105	150	150	170	170
	Ø T	18	18	18	18	18	18	23	23	23	23	23	27
1111	Weight (Kg)	3.1	4.27	5.27	5.78	7.4	10.15	11.74	19.6	30	40	54	75
1112	Weight (Kg)	3.07	4.57	4.89	5.95	7.58	10.22	12.23	19	30	40	54	75

- Levers :

DN 40 – 100

DN 125 – 200

DN 250 - 300

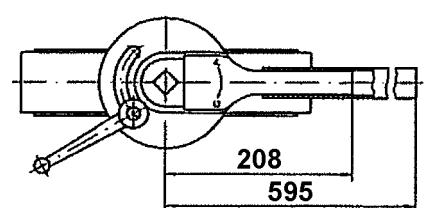
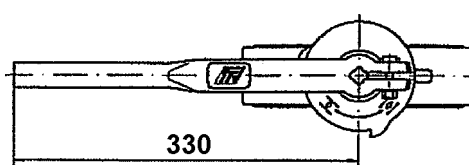
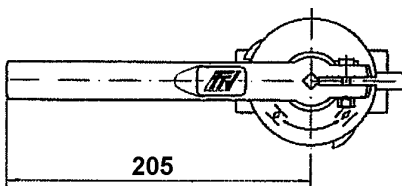

METAL/METAL WAFER BUTTERFLY VALVE (NO TIGHTNESS)

SIZE GN10 (in mm) :

- Valves DN 450 - 1400 :

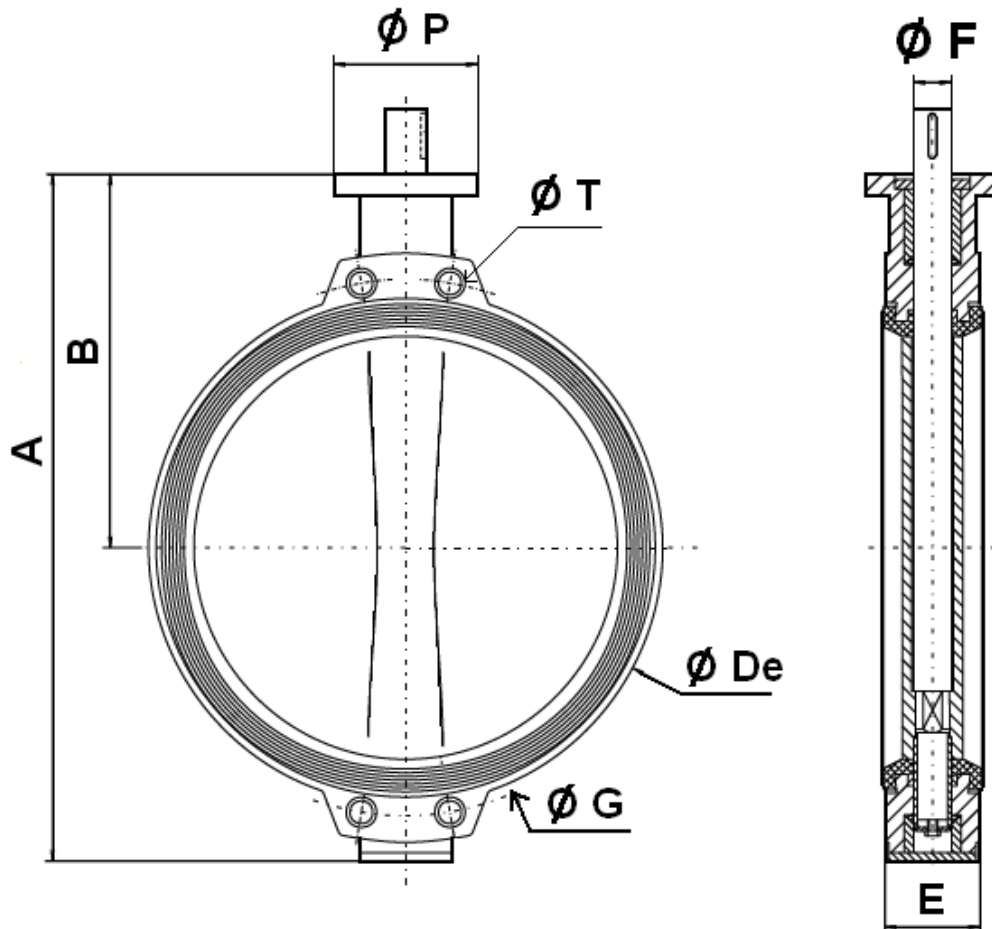

DN	450	500	600	700	750	800	900	1000	1100	1200	1300	1400
A	738	822	965	1100	1150	1248	1325	1457	1580	1720	1910	1990
B	394	440	507	575	600	655	685	754	815	873	1005	1025
Ø De	538	595	695	804	860	911	1010	1124	1225	1330	1460	1530
E	114	127	154	165	190	190	203	216	216	254	360	360
Ø F	50	50	60	60	65	65	80	80	80	100	120	120
Ø G	565	620	725	840	900	950	1050	1160	1270	1380	-	1590
Ø P	175	175	250	300	300	300	300	300	300	300	350	350
Ø T	M24	M24	M27	M27	M30	M30	M30	M33	M33	M36	-	M39
Weight (Kg)	117	153	240	327	381	429	636	835	1050	1305	2011	2320

METAL/METAL WAFER BUTTERFLY VALVE (NO TIGHTNESS)

SIZE GN10 (in mm) :

- Valves with gear box DN 40 - 400 :

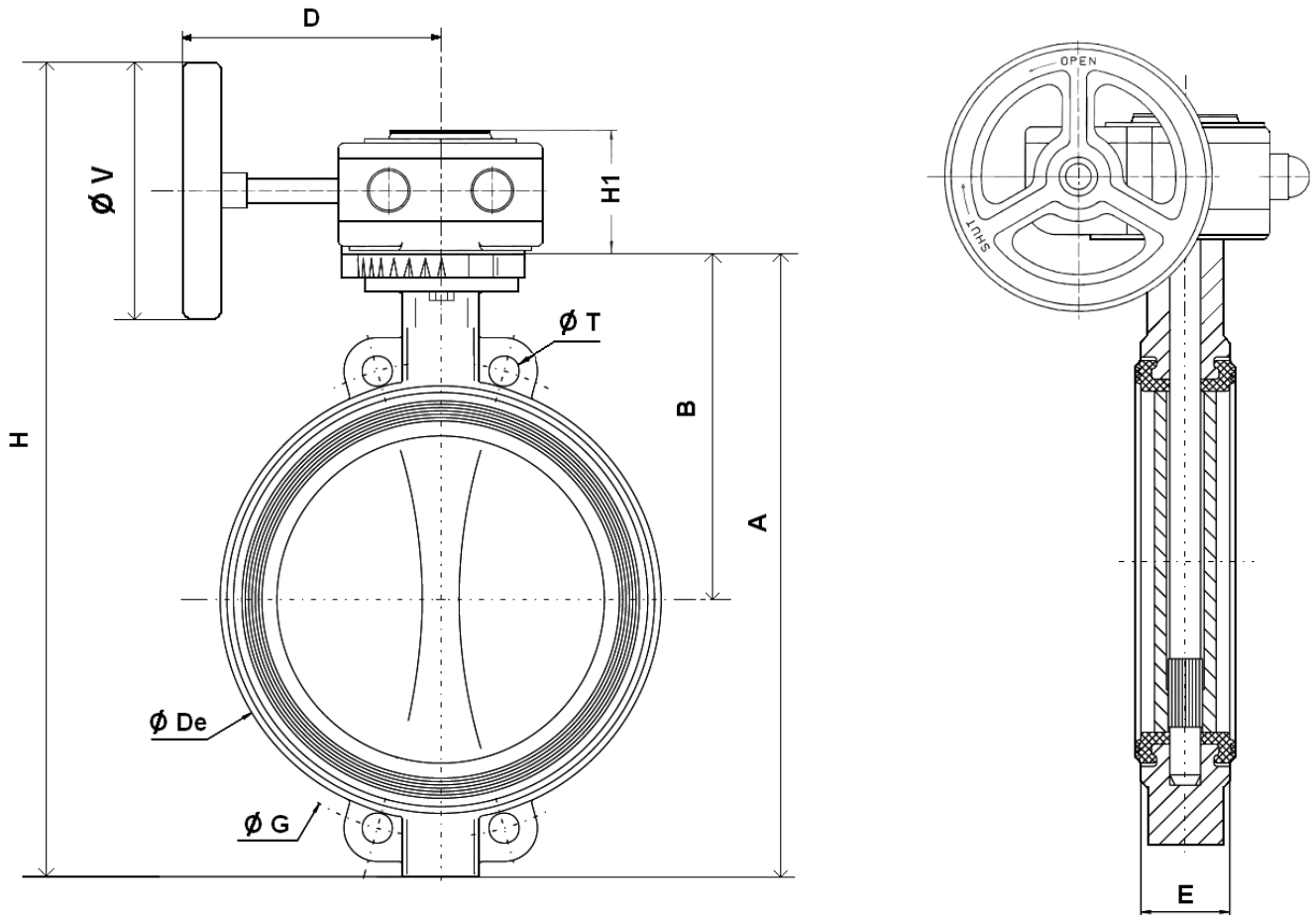

Ref	DN	40	50	65	80	100	125	150	200	250	300	350	400
1111	A	206	228	243	266	294	324	349	438	461	523	582	645
	B	140	156	162	170	185	207	216	256	248	280	300	340
	phi De	82	102	119	135	155	185	208	270	328	381	437	486
	D	120	120	120	120	120	136	136	136	223	223	345	345
	E	33	43	46	46	52	56	56	60	68	78	78	102
1112	H	304	326	341	364	392	452	477	566	647	709	831	894
	H1	58	58	58	58	58	58	58	58	74	74	98	98
	phi G	110	125	145	160	180	210	240	295	350	400	460	515
	phi T	18	18	18	18	18	18	23	23	23	23	23	27
	phi V	140	140	140	140	140	200	200	200	300	300	400	400
1111	Weight (Kg)	4.45	5.62	6.62	7.13	8.75	11.9	13.49	21.35	34	44	63.5	84.5
1112	Weight (Kg)	4.42	6.92	6.24	7.3	8.93	11.97	13.98	20.75	34	44	63.5	84.5

METAL/METAL WAFER BUTTERFLY VALVE (NO TIGHTNESS)

SIZE GN10 (in mm) :

- **Valves with gear box DN 450 - 1400 :**

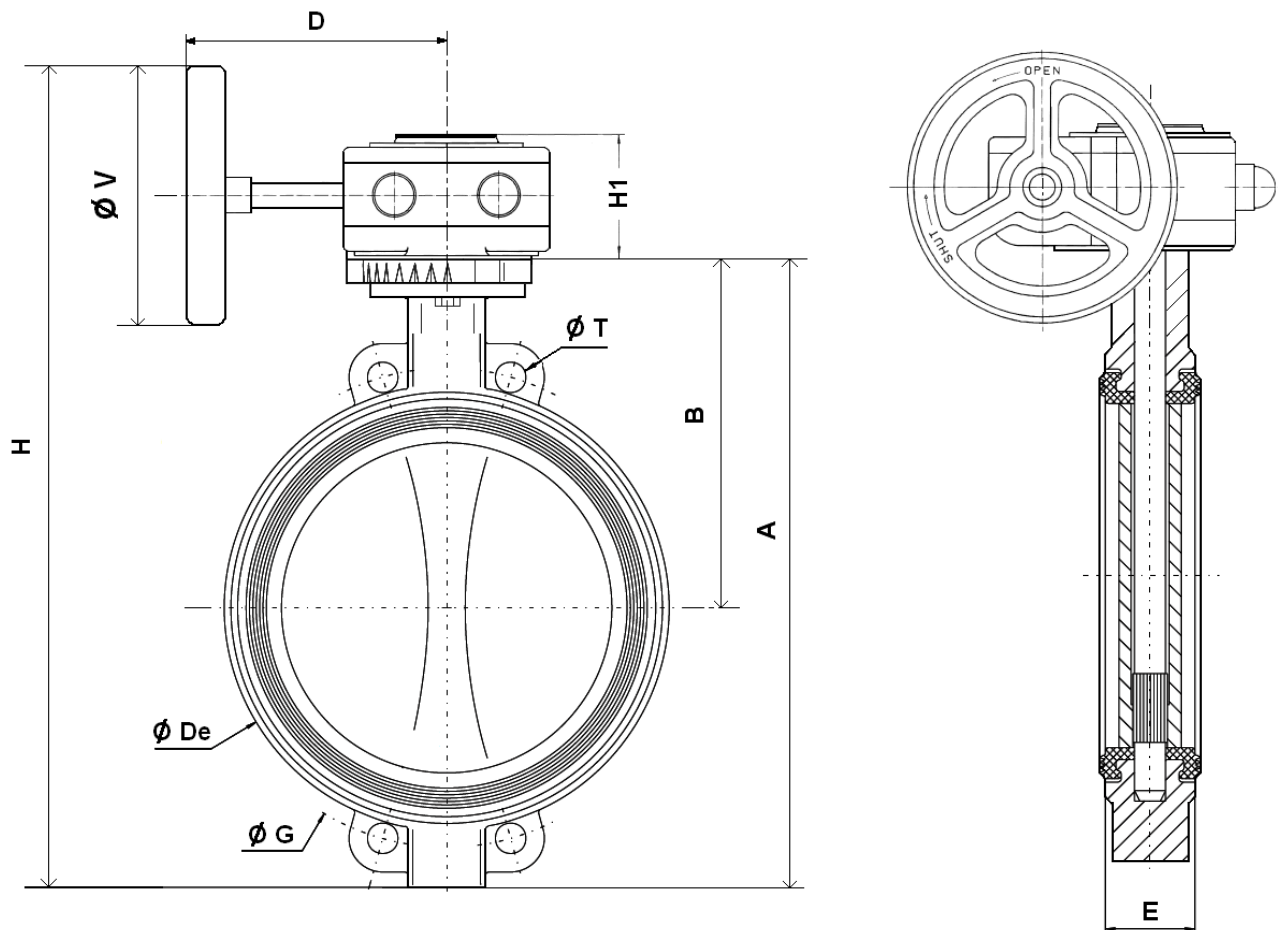

DN	450	500	600	700	750	800	900	1000	1100	1200	1300	1400
A	738	822	965	1100	1150	1248	1325	1457	1580	1720	1910	1990
B	394	440	507	575	600	655	685	754	815	873	1005	1025
Ø De	538	595	695	804	860	911	1010	1124	1225	1330	1460	1530
D	364	386	421	440	440	438	492	492	492	550	605	605
E	114	127	154	165	190	190	203	216	216	254	360	360
H	1083	1171	1376	1409	1459	1657	1688	1820	1943	2178	2260	2429
H1	90	98	122	117	117	117	125	125	125	115	178	178
Ø G	565	620	725	840	900	950	1050	1160	1270	1380	-	1590
Ø T	M24	M24	M27	M27	M30	M30	M30	M33	M33	M36	-	M39
Ø V	600	600	700	500	500	700	600	600	600	800	700	700
Weight (Kg)	135.8	179.8	278.3	376	430	480.3	710.8	909.8	1124.8	1391.5	2243	2552

METAL/METAL WAFER BUTTERFLY VALVE (NO TIGHTNESS)
SIZE GN10 (in mm) :

- Valves with chain gear box :

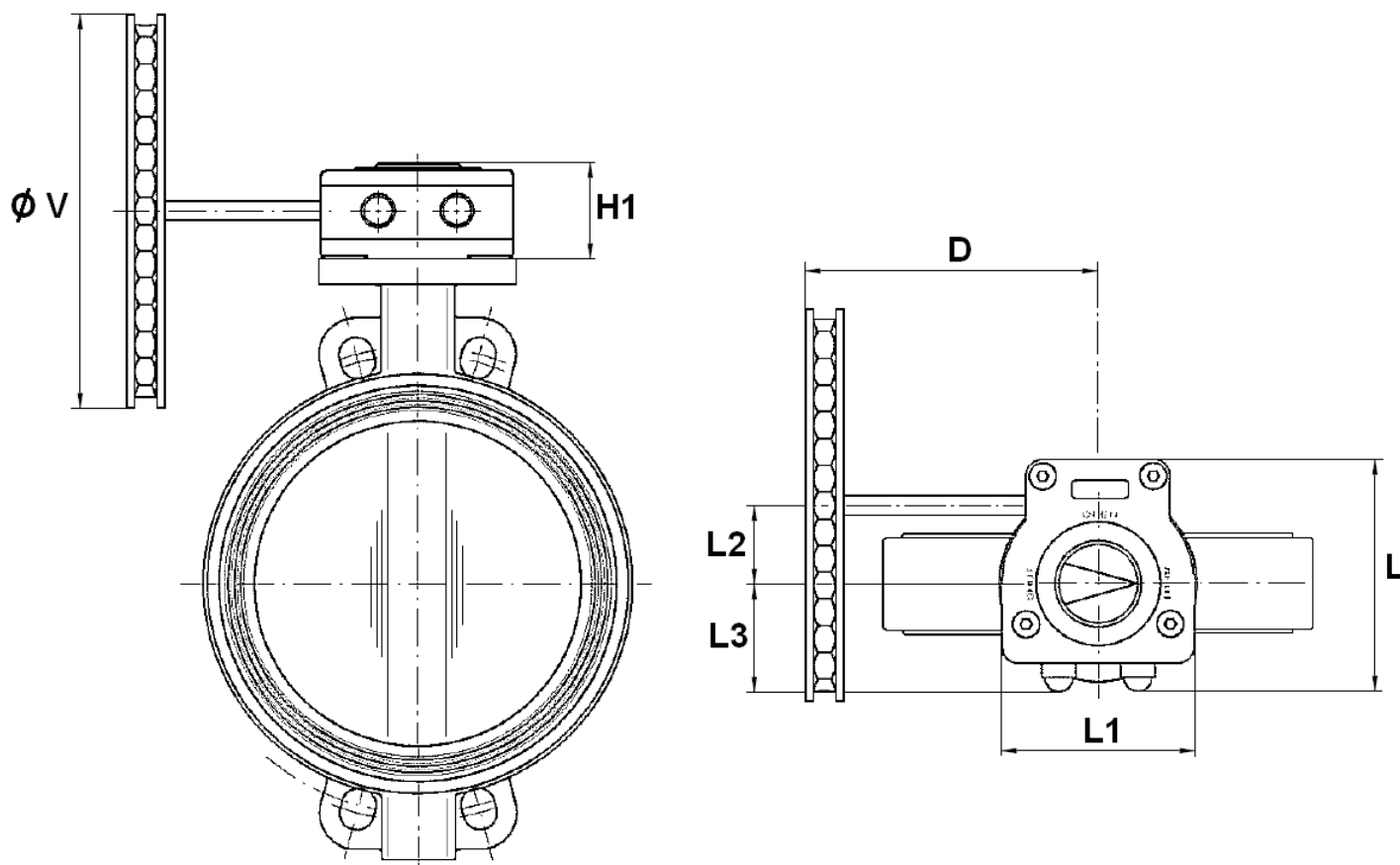

Ref	DN	40	50	65	80	100	125	150	200	250	300	350	400	450	500
1111	D	120	120	120	120	120	126	126	126	214	214	331	331	350	365
	H1	58	58	58	58	58	58	58	58	77	77	88	88	90	98
	L	130	130	130	130	130	130	130	130	177.5	177.5	222	222	232	267
1112	L1	100	100	100	100	100	100	100	100	146	146	175	175	204	227
	L2	50	50	50	50	50	50	50	50	60	60	80	80	86	104.5
	L3	58	58	58	58	58	58	58	58	82.5	82.5	85	85	100	110
	ø V	125	125	125	125	125	210	210	200	300	300	400	400	500	500
1111	Weight (Kg)	5.45	6.62	7.62	8.13	9.75	12.9	14.49	22.35	36.8	46.8	68.3	89.3	143.2	186.7
1112	Weight (Kg)	5.42	6.92	7.24	8.3	9.93	12.97	14.98	21.75	36.8	46.8	68.3	89.3	143.2	186.7

METAL/METAL WAFER BUTTERFLY VALVE (NO TIGHTNESS)

SIZE GN10 (in mm) :

- Stem extension for isolation (75 mm) :

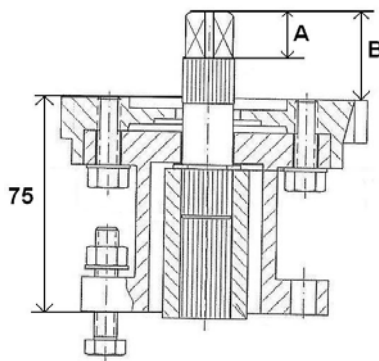

DN	40-50	65	80-100	125-150	200
A	19	19	19	17	17
B	34	34	34	34	34
Weight (Kg)	0.8	0.8	0.9	0.9	1

- Square lever for special key (30x30 mm) :

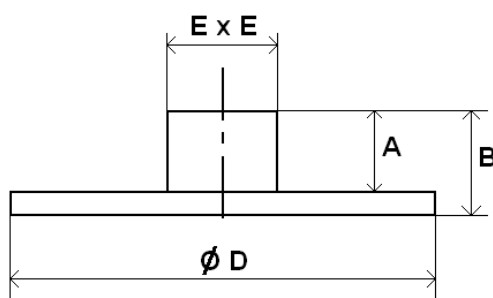

DN	40-50	65	80-100	125-150	200
A	20	20	20	20	20
B	31	31	32	32	32
Ø D	107	107	107	107	107
E x E	30 x 30	30 x 30	30 x 30	30 x 30	30 x 30
Weight (Kg)	0.88	0.88	0.88	0.88	0.88

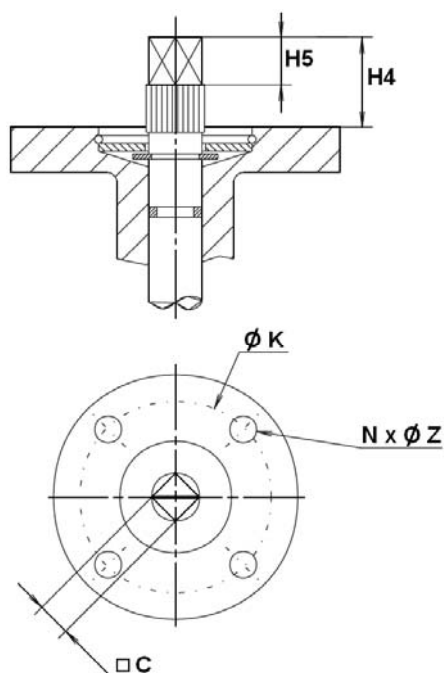
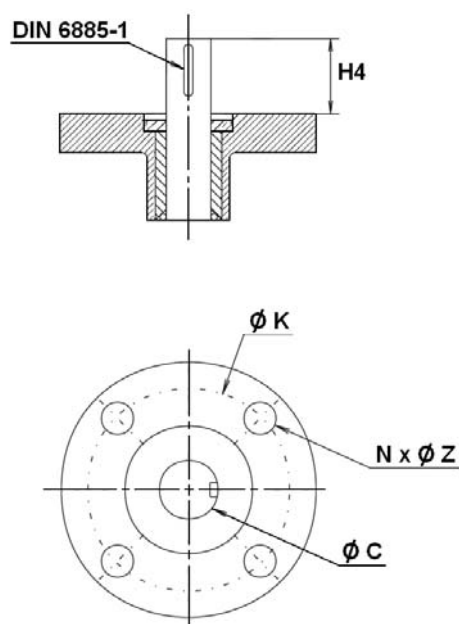
METAL/METAL WAFER BUTTERFLY VALVE (NO TIGHTNESS)
ISO MOUNTING PAD AND STEM SIZE (in mm) :
DN 40 – 400

DN 450 - 1400

DN	40	50	65	80	100	125	150	200	250	300	350	400
H4	30	30	30	30	30	30	30	30	40	40	40	40
H5	17	17	17	17	17	17	17	17	20	20	20	20
C	8	8	9	11	11	14	14	17	19	22	22	27
Ø K	70	70	70	70	70	70	70	70	102	102	140	140
ISO	F07	F07	F07	F07	F07	F07	F07	F07	F10	F10	F14	F14
N x Ø Z	4 x 9	4 x 9	4 x 9	4 x 9	4 x 9	4 x 9	4 x 9	4 x 9	4 x 11	4 x 11	4 x 18	4 x 18

DN	450	500	600	700	750	800	900	1000	1100	1200	1300	1400
H4	80	80	90	90	110	110	110	110	110	110	120	120
Ø C	50	50	60	60	65	65	80	80	80	100	120	120
Ø K	140	140	165	254	254	254	254	254	254	254	298	298
ISO	F14	F14	F16	F25	F25	F25	F25	F25	F25	F25	F30	F30
N x Ø Z	4 x 18	4 x 18	4 x 22	8 x 18	8 x 18	8 x 18	8 x 18	8 x 18	8 x 18	8 x 18	8 x 22	8 x 22

METAL/METAL WAFER BUTTERFLY VALVE (NO TIGHTNESS)**STANDARDS :**

- Fabrication according to ISO 9001:2008
- DIRECTIVE 97/23/CE : CE N° 0409
Risk Category III module B + C1
- Tests according to ISO 5208
- Between flanges according to EN 1092-1 PN10
- ISO 5211 mounting pad
- Length according to ISO 5752 short series 20, BS 5155 Wafer short/medium, DIN 3202 part 3, series K1
- ATEX Group II Category 2 G/2D Zone 1 & 21 Zone 2 & 22 (optional marking)
- Approval certificate Russian **GOST-R**
- OTAN agreement (N° 286B)

ADVICE : Our opinion and our advice are not guaranteed and SFERACO shall not be liable for the consequences of damages.
The customer must check the right choice of the products with the real service conditions.

METAL/METAL WAFER BUTTERFLY VALVE (NO TIGHTNESS)**INSTALLATION INSTRUCTIONS****GENERAL GUIDELINES :**

- Ensure that the valves to be used are appropriate for the conditions of the installation (type of fluid, pressure and temperature).
- Be sure to have enough valves to be able to isolate the sections of piping as well as the appropriate equipment for maintenance and repair.
- Ensure that the valves to be installed are of correct strength to be able to support the capacity of their usage.
- **Installation of all circuits should ensure that their function can be automatically tested on a regular basis (at least two times a year).**

INSTALLATION INSTRUCTIONS :

- **Before installing the valves, clean and remove any objects from the pipes** (in particular bits of sealing and metal) which could obstruct and block the valves.
- **Ensure that both connecting pipes either side of the valve (upstream and downstream) are aligned (if they're not, the valves may not work correctly).**
- **Make sure that the two sections of the pipe (upstream and downstream) match, the valve unit will not absorb any gaps. Any distortions in the pipes may affect the tightness of the connection, the working of the valve and can even cause a rupture.** To be sure, place the kit in position to ensure the assembling will work.
- **If sections of piping do not have their final support in place, they should be temporarily fixed. This is to avoid unnecessary strain on the valve.**
- Tighten the bolts in cross.
- The disc must move easily inside the pipe.
- Valves must be opened during cleaning operation.
- Tests must be done with a cleaned pipe.
- Tests must be done with opened valve. Test pressure must not be higher than the valve specification according to EN 12266-1.
- Then open slowly the valve.
- **Do not mount butterfly valves with stainless steel pressed collars and turning flanges without strias.**
- **And not on flat face flanges without strias (example : painted cast iron fittings)**

MAINTENANCE :

- We recommend to operate fully the valve 1 to 2 times per year.
- During maintenance operation, ensure that the pipe isn't under pressure, that there's no fluid in the pipe and that the valve is isolated. If there's a fluid in the pipe, evacuate it. Ensure that there are no risks due to the temperature or the fluid (like acids). If the fluid is corrosive, inert the installation before maintenance operation.