

# Horticulture

Circulation Pumps

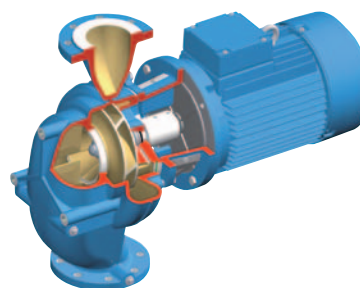
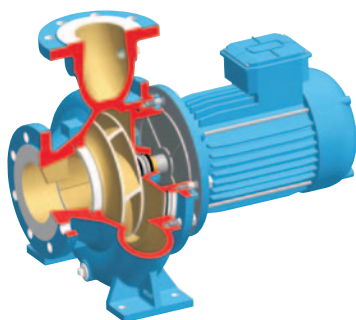
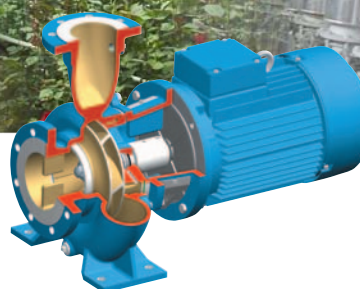

# Pump applications in Horticulture Greenhouses

More than a century ago greenhouse horticulture activities started in the "Westland" area in the Netherlands. Over the years in this region a specialised infrastructure arose, uniting growers, trade channels and suppliers of greenhouse components.

During the last decades extensive research and constant innovation lead to the introduction of more and more technological systems in the greenhouse.

These developments turned greenhouse activities into a high-tech technology that nowadays is exported worldwide. This technology includes the pump circulation systems and related control systems.

Due to its highly specialised infrastructure the "Westland" area always remained a key factor in the supply chain of greenhouse technology. Many leading companies of greenhouse systems and components are Westland based. One of them is SPX Flow Technology.

By adopting state-of-the-art technology and constant focusing on client demands SPX is able to follow the technological developments in and around the greenhouse rapidly and adequately.

## Circulation pumps

Thanks to this technological approach the growing conditions in the greenhouse can be accurately controlled and managed. One of the key factors for obtaining optimal growing conditions is efficient temperature control. The reliable performance of the circulation pumps is of paramount importance to this process. Another key factor is low energy consumption of the used equipment.

SPX's Johnson Pump circulation pumps combine the highest reliability with optimal efficiency, making it by far the most suitable pump for both heating and cooling systems.

Depending on the ambient temperature and the selected growing program the heat demand in the greenhouse may vary considerably. Due to smart solutions, like continuous flow control, the present systems are able to constantly adapt themselves to these varying conditions.

Flow control can be obtained by adopting frequency controlled motors on the circulation pumps. This requires a versatile performance of the pumps and the capacity to operate smoothly at different speeds and different duty points.

SPX supplies a range of low-speed circulation pumps, available as in-line pumps or as close-coupled monobloc pumps.

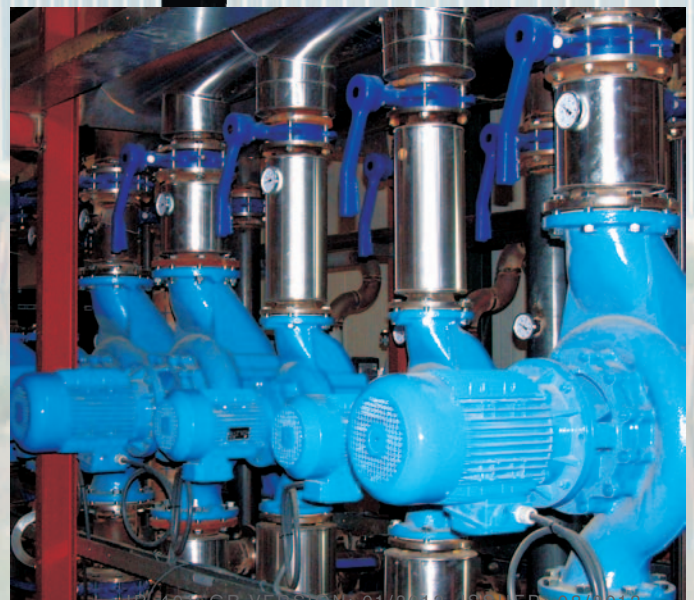

# Pump types

The Horticulture circulation pumps comprise the following range:

## CombiLine (CL)

## CombiLineBloc (CLB)

CombiLine (CL) and CombiLineBloc (CLB) pumps are build-in in-line pumps. These pumps are easy to install in straight pipelines; inlet and outlet flange connections have the same size and pattern and are positioned in-line.

## CombiBlocHorti (CBH)

## CombiBloc (CB)

CombiBlocHorti (CBH) and CombiBloc (CB) are close coupled foot-mounted volute pumps. These pumps are characterised by a compact build and a pump casing with horizontal inlet and vertical outlet.

CL and CBH share the same impeller/shaft seal/drive section (Back-Pull-Out unit).

For this design the electric motor is provided with an extended, stainless steel motor shaft. The impeller is mounted directly onto the motor shaft.

CLB and CB also share the same Back-Pull-Out unit. In this design the pump is assembled with a standard IEC flange motor with a stub shaft fitted onto the motor shaft. The electric motor is mounted to the pump cover by means of a lantern piece.

**All pump types are fitted with a rubber bellows mechanical seal, according to EN 12756 (DIN 24960).**

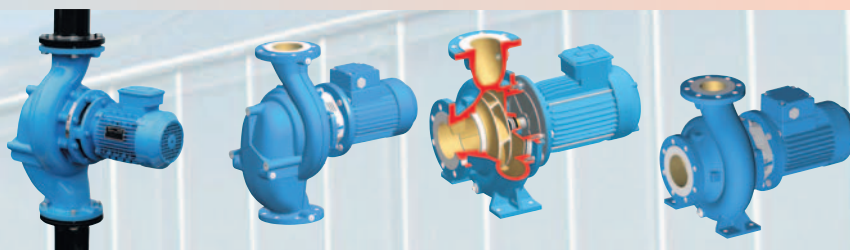

## Technical specifications

		CL / CLB	CBH / CB
<b>Maximum capacity</b>	50 Hz:	400 m <sup>3</sup> /h	600 m <sup>3</sup> /h
	60 Hz:	500 m <sup>3</sup> /h	800 m <sup>3</sup> /h
<b>Delivery head</b>	50 Hz:	1 - 28 m	1 - 35 m
	60 Hz:	2 - 40 m	2 - 50 m
<b>Maximum temperature</b>		140 °C	140 °C
<b>Maximum working pressure</b>		6 bar (ND6) 10 bar (ND10)	10 bar (ND10)
<b>Materials</b>	pump casing	EN-GJL-250 (GG25)	EN-GJL-250 (GG25)
	impeller	EN-GJL-200 (GG20)	EN-GJL-200 (GG20)
	motor shaft	X17CrNi 16-2 (1.4057)	X17CrNi 16-2 (1.4057)
	stub shaft	X2CrNiMo17.12.2 (1.4404)	X2CrNiMo17.12.2 (1.4404)
	shaft sleeve	G-CuSn7ZnPb (Rg 7)	G-CuSn7ZnPb (Rg 7)
<b>Nominal motor speed</b>		1450 min <sup>-1</sup> , 50 Hz 4 poles 950 min <sup>-1</sup> , 50 Hz 6 poles 1750 min <sup>-1</sup> , 60 Hz 4 poles 1150 min <sup>-1</sup> , 60 Hz 6 poles	
<b>2 speed motor with Dahlander connection</b>		1450/950 min <sup>-1</sup> , 50 Hz 4/6 poles 1750/1150 min <sup>-1</sup> , 60 Hz 4/6 poles	
<b>Frequency control wall mounted</b>		from 1.1 kW, range 10 to 60 Hz	
<b>Electric motor protection class</b>		IP55	
<b>Electric motor voltage</b>		230/400 V (≤ 1.5 kW), 50 Hz 400/695 V (≥ 2.2 kW), 50 Hz 277/480 V (≤ 1.5 kW), 60 Hz 480/830 V (≥ 2.2 kW), 60 Hz other voltages/speeds on request	
<b>Mechanical seal</b>		EN 12756 (DIN 24960), AQ1EGG carbon/silicon carbide, EPDM bellows	

# Design features

## BACK-PULL-OUT UNITS

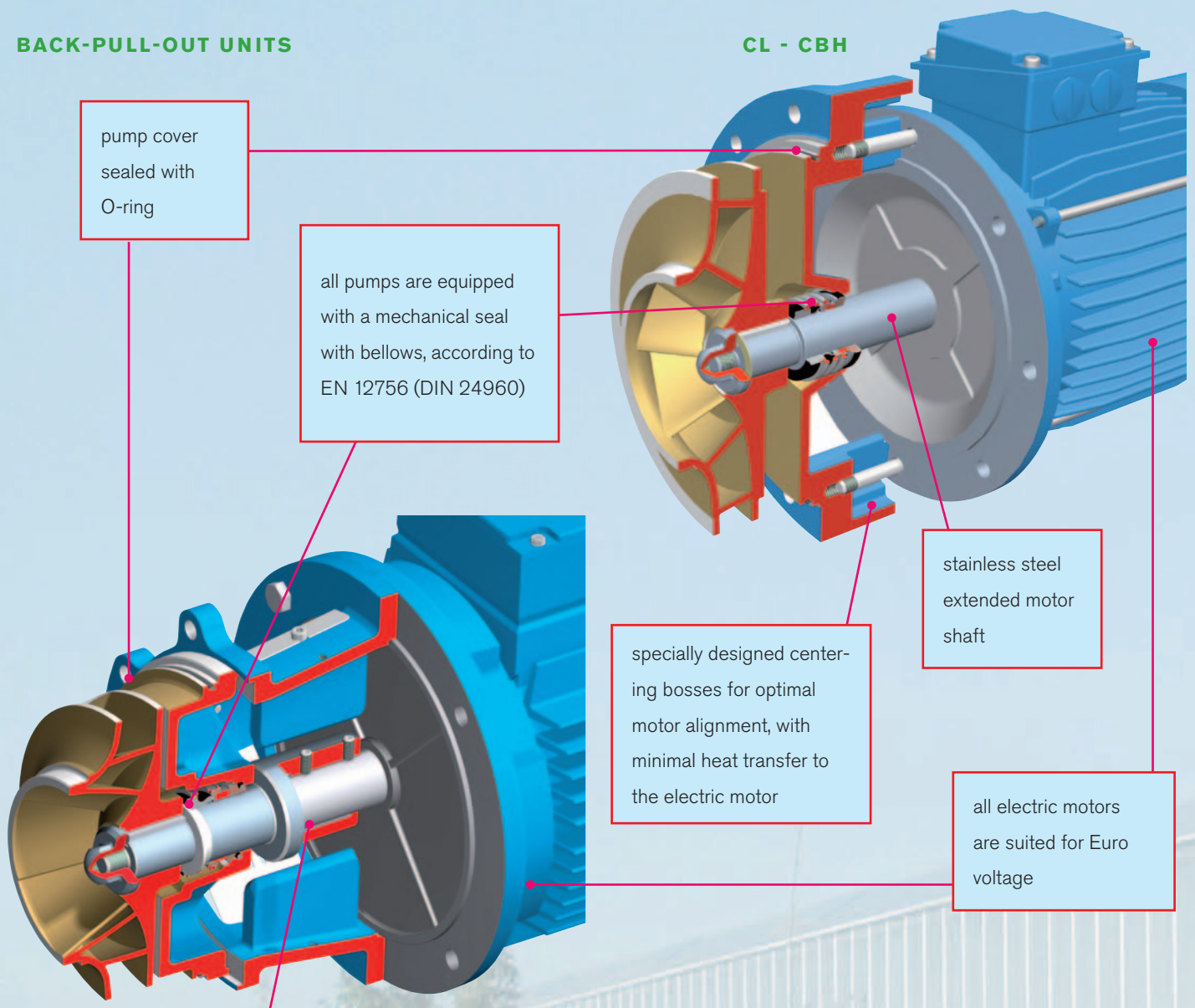

pump cover sealed with O-ring

all pumps are equipped with a mechanical seal with bellows, according to EN 12756 (DIN 24960)

CL - CBH

stainless steel extended motor shaft

specially designed centering bosses for optimal motor alignment, with minimal heat transfer to the electric motor

all electric motors are suited for Euro voltage

CLB - CB

stainless steel stub shaft

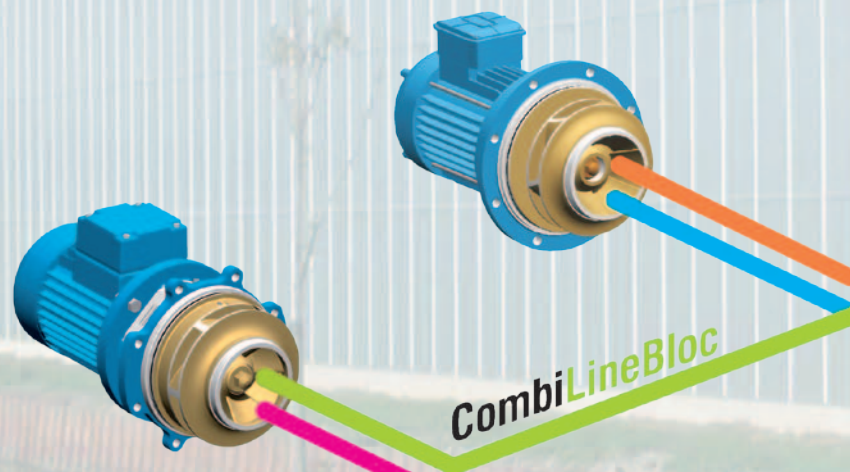

CombiLineBloc

The hydraulic parts of all pump types have been optimized by using CFD (Computational Fluid Dynamics) during the design stage of the pump. Extensive testing at the SPX test laboratories proved that the pumps amply meet their design specifications.

# Design features

## PUMP CASINGS

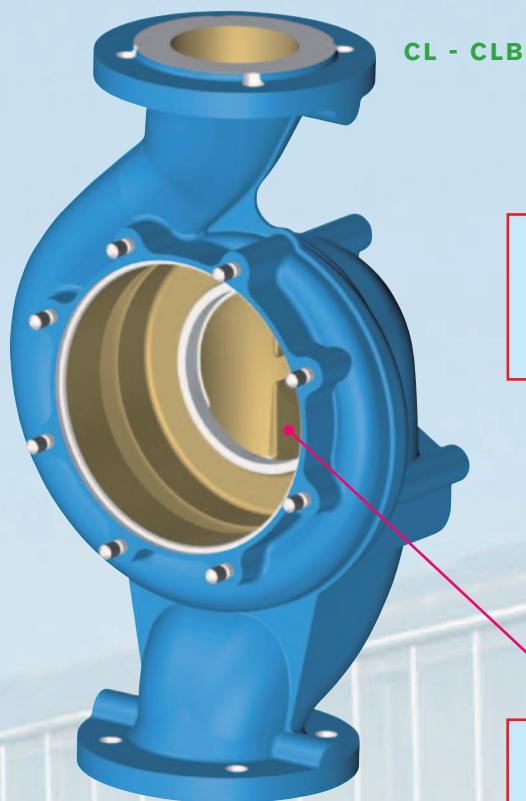

cast-on bosses with threaded holes, for wall or floor mounting of the pump

a specially designed suction bend ensures an optimal NPSH

pump entry is provided with anti-rotation vanes to prevent vortex in the impeller inlet

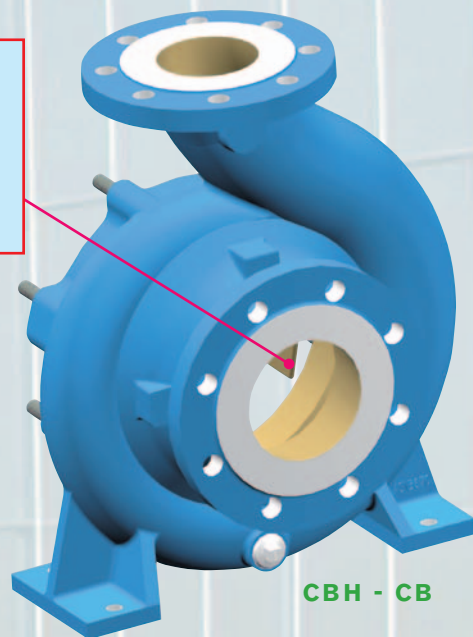
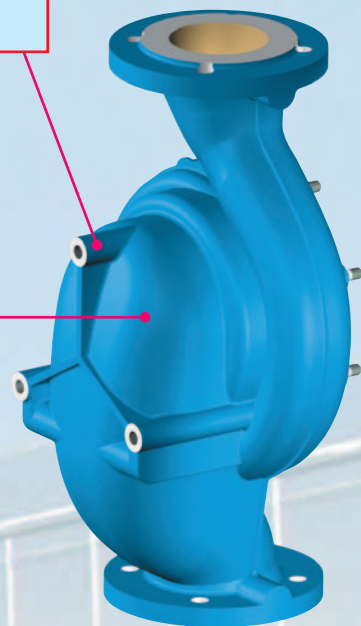

**CombiLine**

**CombiBlocHorti**

**CombiBloc**

All pumps are designed according to a strong modular concept, resulting in a high degree of interchangeability of mutually equal components between the pump families (see diagram at the left).

# Pump configurations

The following overview shows the possible pump configurations of the Horticulture pump range.

## COMBILINE

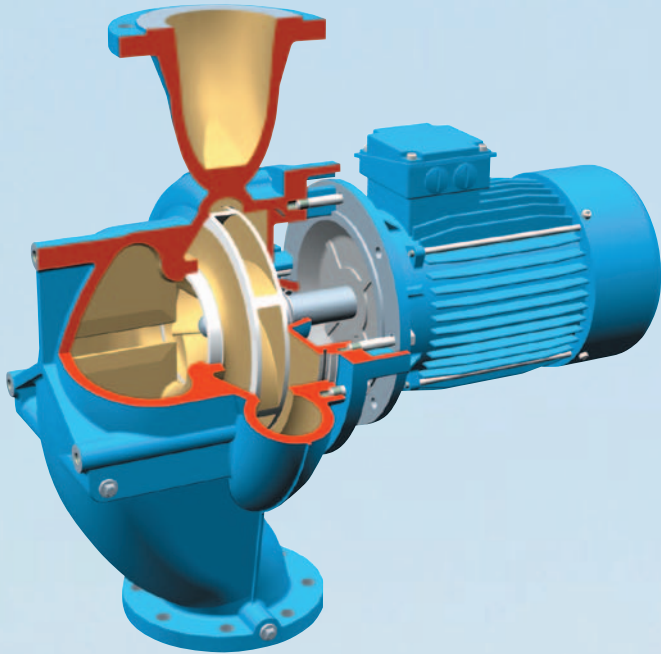

## COMBIBLOCHORTI

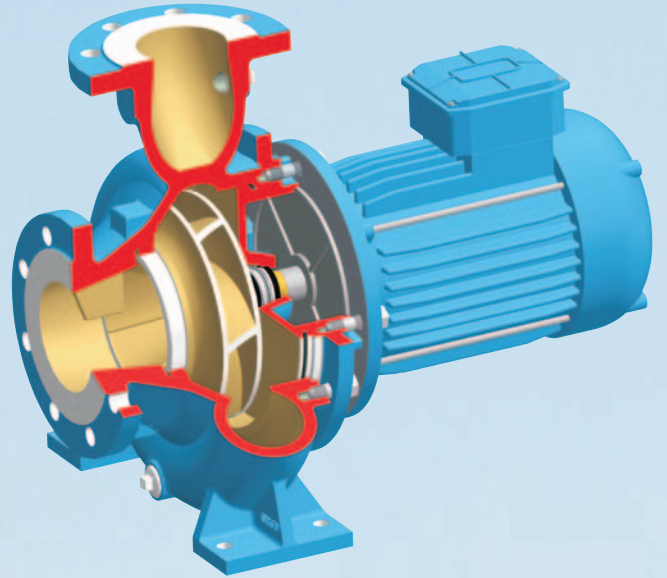

## COMBILINEBLOC

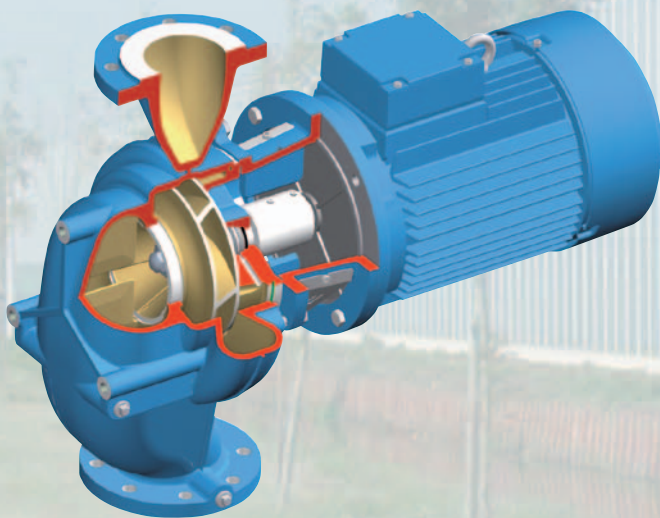

## COMBIBLOC

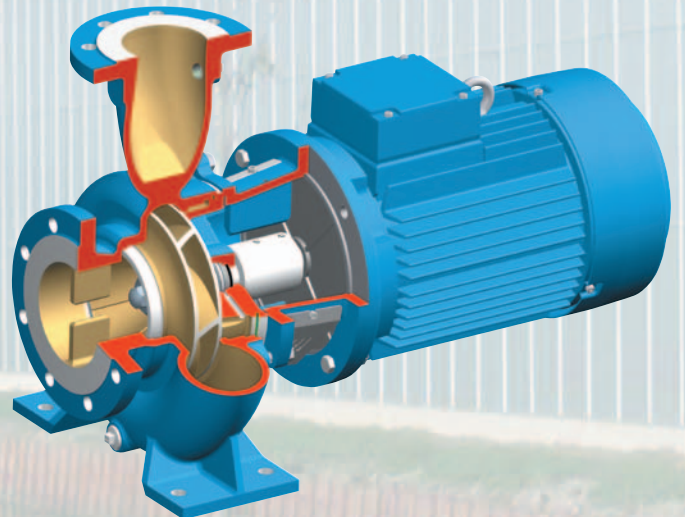

# Pump mounting positions

It is possible to mount the pump in several different positions between the lines of the system, in horizontal as well as in vertical position. However, not all the possible positions are allowed. This overview shows the allowed mounting positions of the pumps of the Horticulture range.

Horizontal, with motor in horizontal position, connecting box on top.

CL  
CLB  
CBH  
CB

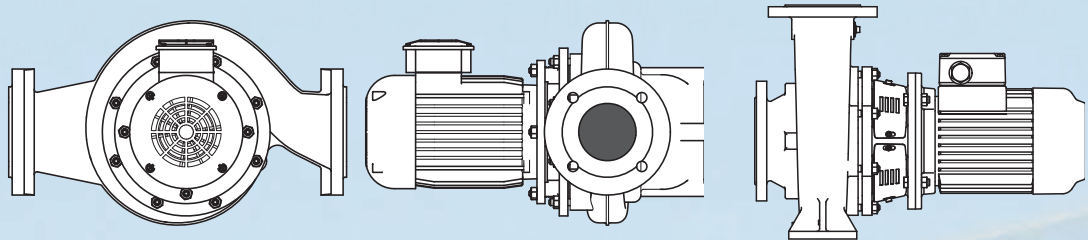

Vertical, with motor in horizontal position, connecting box on top.

CL  
CLB

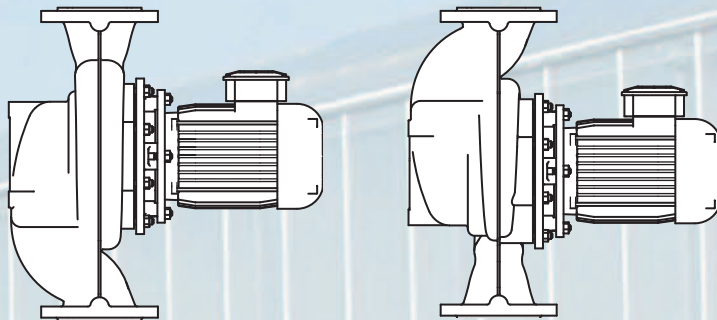

Horizontal, with motor in vertical position. If necessary, the pump can be mounted on a base plate and foundation to avoid pump loads to the pipe work in case of large weighty pump types.

CL  
CLB  
CBH  
CB

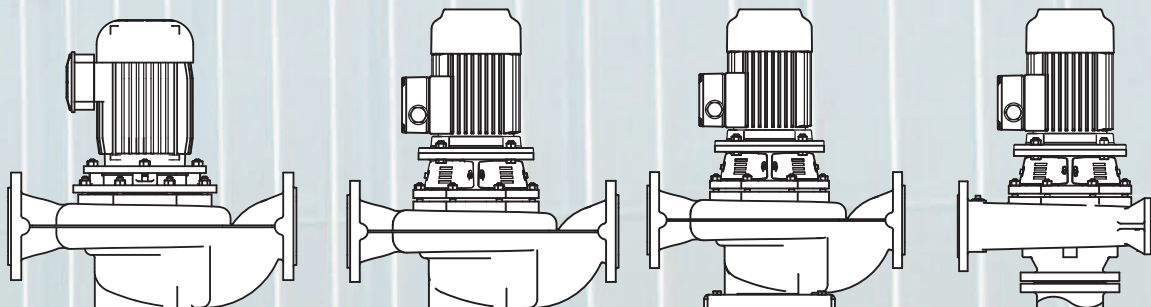

The following mounting configurations are **not allowed**:

CL  
CLB  
CBH  
CB

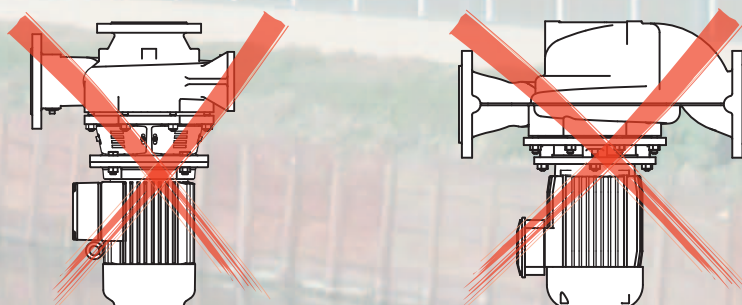

# Performance curves

## In-line pumps CL and CLB



These performance curves are based on standard electric motor speeds and refer to water with a temperature of 20 °C.

Hydraulic flow field CL and CLB at 50Hz 4 poles

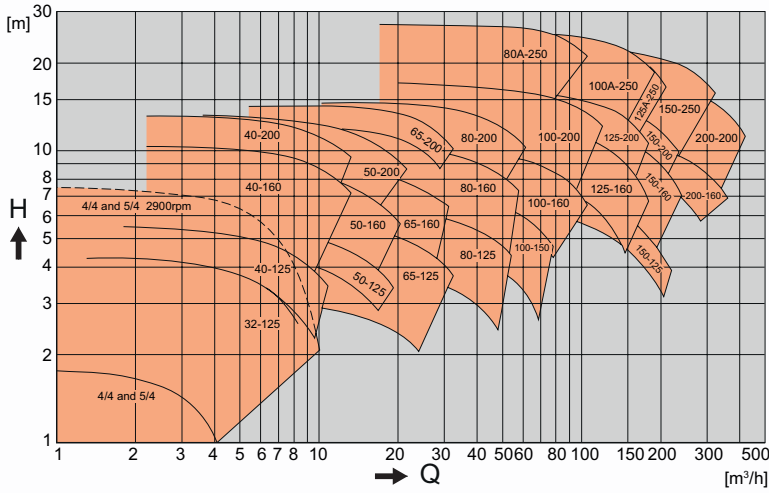

Hydraulic flow field CL and CLB at 60Hz 4 poles

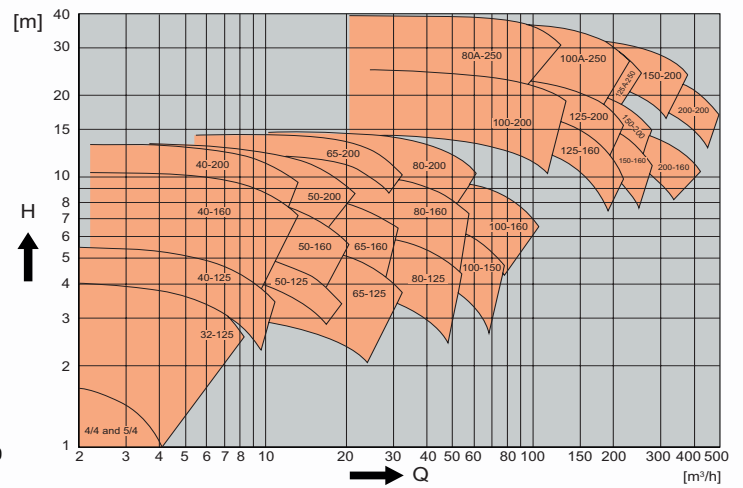

Hydraulic flow field CL and CLB at 50Hz 6 poles

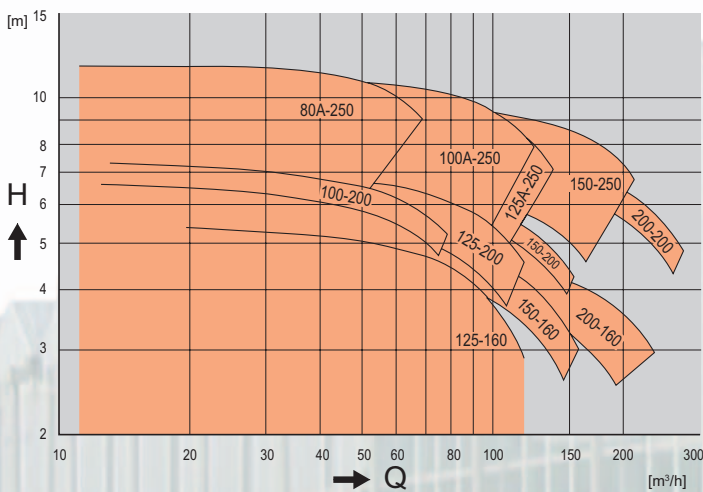

Hydraulic flow field CL and CLB at 60Hz 6 poles

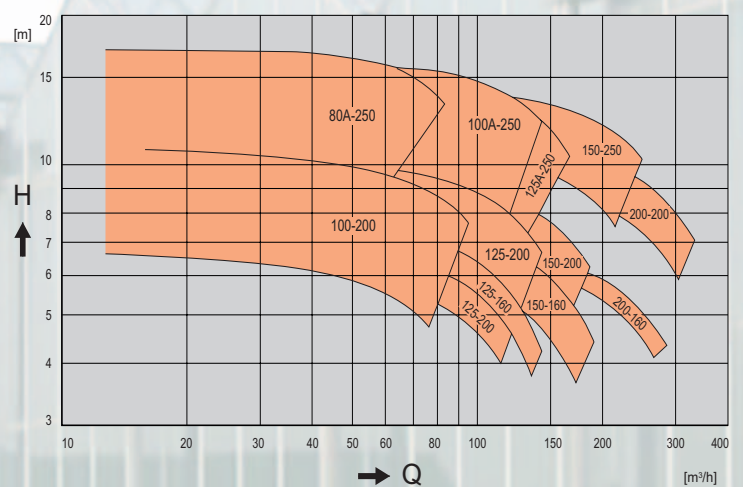



# Performance curves

## Monobloc pumps CBH and CB



These performance curves are based on standard electric motor speeds and refer to water with a temperature of 20 °C.

Hydraulic flow field **CBH and CB** at 50Hz 4 poles

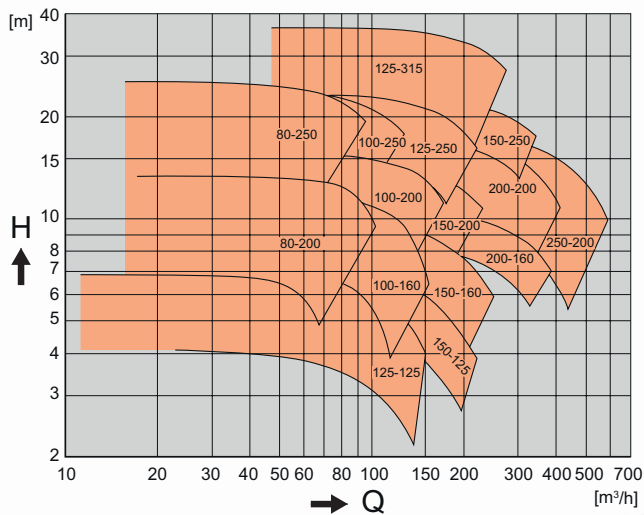

Hydraulic flow field **CBH and CB** at 60Hz 4 poles

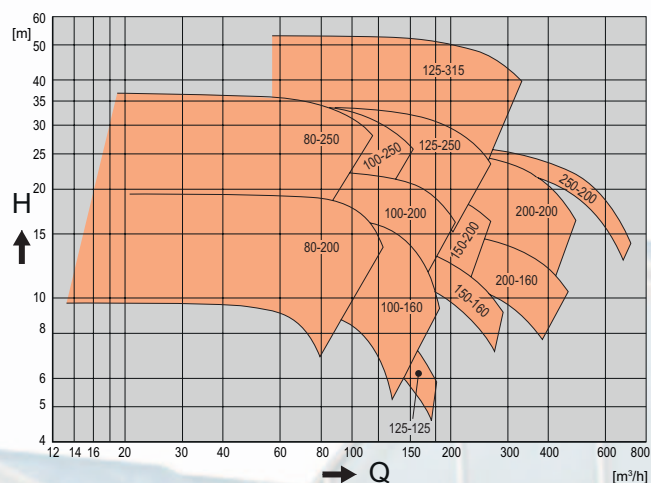

Hydraulic flow field **CBH and CB** at 50Hz 6 poles

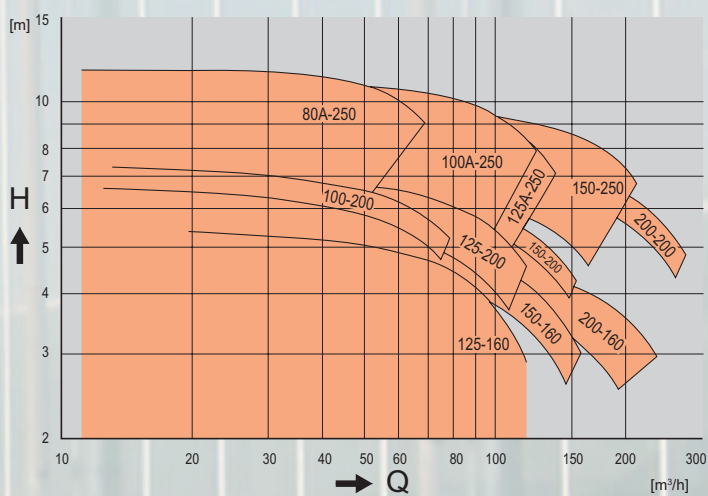

Hydraulic flow field **CBH and CB** at 60Hz 6 poles

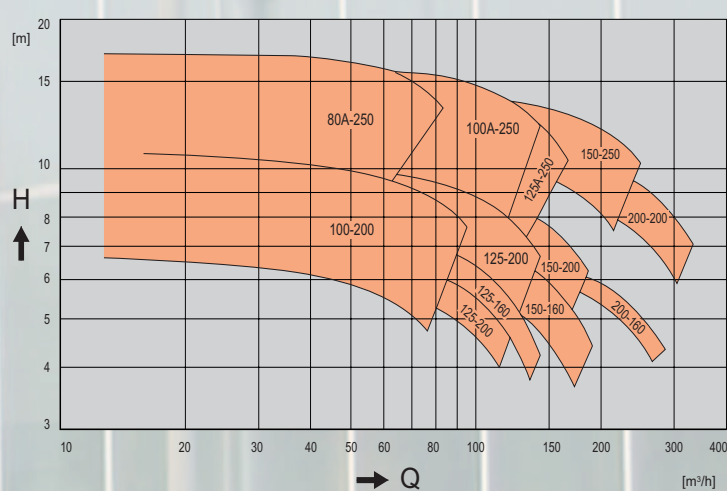

# Circulation systems

## HEATED WATER CIRCULATION

Water circulation systems in the greenhouse are heated by a boiler or by heated water buffered in a large tank. The burner of the boiler also supplies the CO<sub>2</sub> gas for growth; in those situations the heat is stored in the buffer tank. The heat might also be delivered by external companies, for example a joint facility for total energy supply in greenhouse areas. The heat is delivered to the circulation system by means of a heat exchanger.

A manifold unit and a related control management system distributes the heat to all sections in the greenhouse.

1. Boiler with burner
2. Power / heating unit
3. Buffer tank
4. Manifold unit with circulation pumps
5. External supply of heat
6. Heat exchanger
7. System pressure unit
8. Exhaust gas cleaning unit
9. Cultivated plants area

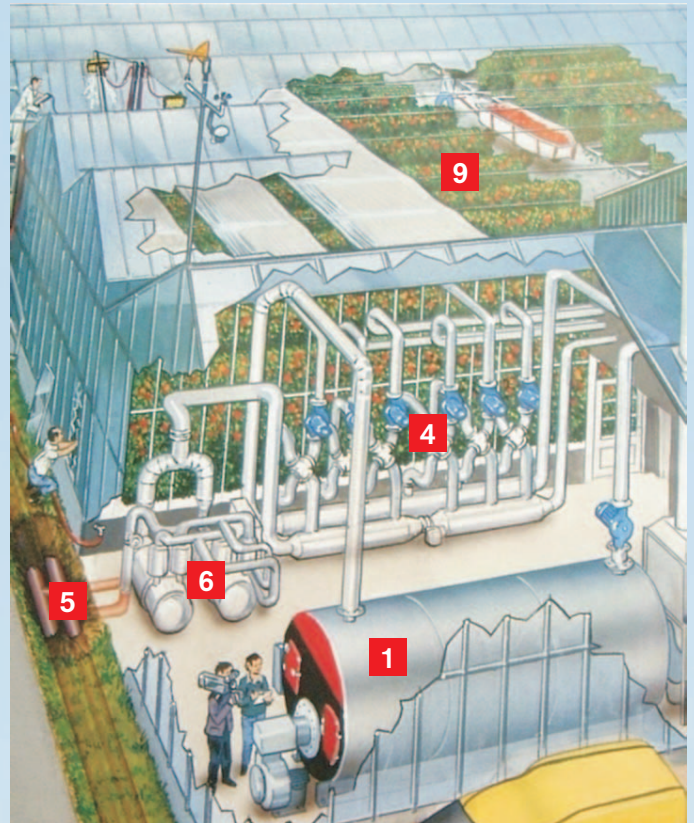

## POWER / HEATING UNIT

A power / heating unit usually consists of a combustion engine running on natural gas and a generator for delivery of electricity. The electricity is used for illumination of the crop, CO<sub>2</sub> gasses from the burner are lead into the greenhouse for growth of the crop and the heat is used for heating the greenhouse or is temporarily stored in the buffer tank. Power / heating units are also applied to compensate peak loads in the electricity supply. In these cases the produced electrical power is supplied to the public electricity grid.

This is a welcome economical benefit for the greenhouse owner, in this way reducing the operational costs of greenhouse exploitation.

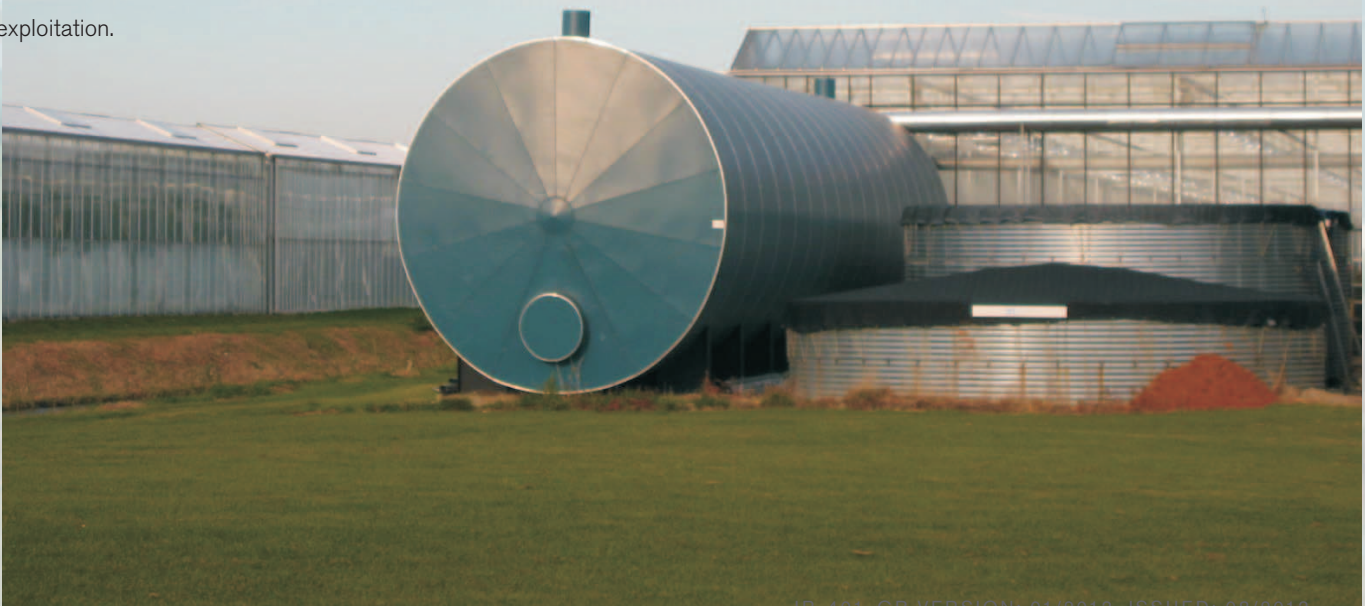
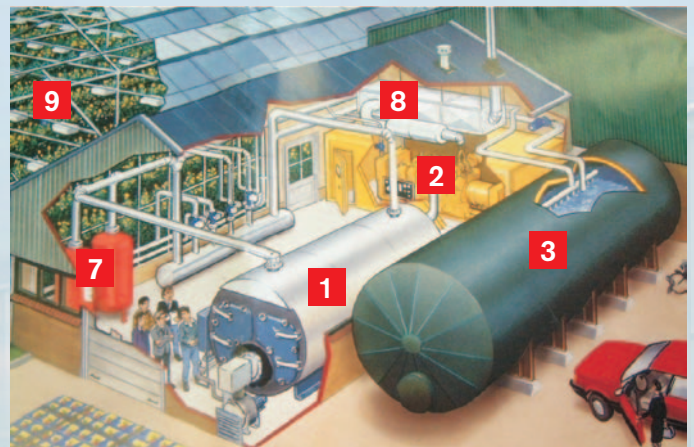

# Saving energy

**WARMTH IS A VALUABLE COMMODITY AND YOU MUST APPLY IT RATIONALLY!**

## INSULATED PUMPS AND VALVES

Not many investment costs are recovered as quickly as when insulating the fittings in your central heating system, boiler house or technical spaces. Oddly enough, while most pipes are sufficiently insulated, most pumps, mixing valves, valves and flanges are not.

SPX can supply insulation packages for these products. Our insulation packages can be fitted to the distribution groups to avoid excessive heat radiation.

Every year countless cubic meters of natural gas are wasted because of heat losses, while they can simply and effectively be saved.

Annual savings for a central heating installation with a temperature difference of 60 °C and a 125 mm connection can mount up to:

- Pump 350 m<sup>3</sup> gas per year
- Mixing valve 300 m<sup>3</sup> gas per year
- Valves 120 m<sup>3</sup> gas per year

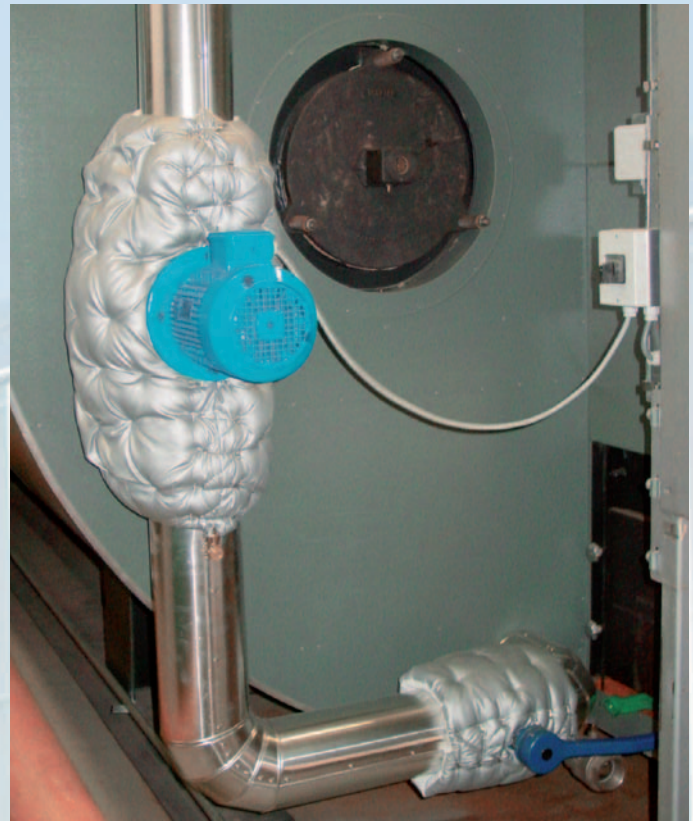

## TWO-SPEED MOTOR DRIVE

A very simple way of saving energy is applying a 4/6 pole changing motor for direct-on-line starting with a so-called "Dahlander" connection.



# Frequency controlled motor drives

In a unique cooperation with Danfoss, SPX can supply pumps with frequency controlled motor drive. In this way world wide service expertise and “online” support are guaranteed.



## VLT® HVAC DRIVE FC 102

It offers a vast number of pump-specific features developed in cooperation with OEMs, contractors and manufactures all over the world. The VLT® HVAC Drive FC 102, built on Danfoss' new modular plug-and-play platform and dedicated to HVAC applications, makes HVAC operation easy. Operators, equipment and control systems all communicate effortlessly with the VLT® HVAC Drive FC 102.

27 Display languages are available.

The Local Control Panel (LCP) constantly improves on the intuitive man-machine interface.

Automatic Motor Adoption and Automatic Energy Optimisation support fast commissioning.

Due to a series of self-protecting and monitoring features and a highly durable mechanical design, the VLT® HVAC Drive FC 102 is practically maintenance free.

- From 1.1 kW
- Enclosures IP20/chassis, IP21/NEMA 1 & IP55/NEMA12
- Modular plug-and-play platform
- Ambient temperature up to 50 °C
- Automatic Motor Adoption and Automatic Energy Optimisation
- Built-in RFI filter ensures compliance with EMC directives
- Hot-pluggable Local Control Panel (LCP)

## LOCAL CONTROL PANEL (LCP)

### GRAPHICAL DISPLAY

- International characters and signs
- Showing bars and graphs
- Possible to select 27 languages

### MENU STRUCTURE

- Easy shortcut for the experienced user
- Edit and operate in different set-ups simultaneously

### QUICK MENUS

- a Danfoss defined Quick Menu
- a Personal defined Quick Menu
- a Changes Made Menu list the parameters unique for your application
- a function Setup Menu provides quick and easy setup for specific applications
- a Logging Menu provides access to operation history

### OTHER BENEFITS

- Removable during operation
- Up- and download functionality
- IP65 rating when mounted in a panel door
- Numerical version also available
- Important buttons are now illuminated when active



# Hydraulic Investigator

To find the best fitting pump for your pump application in the greenhouse the CombiLine, CombiLineBloc, CombiBlocHorti or CombiBloc ranges are available in a large number of sizes, which covers an ample hydraulic field.

We recommend using our Pump Selection software "Hydraulic Investigator" developed by SPX Flow Technology Assen, to select the best available pump for your particular application.

- Guided pump selection based upon specific needs for any pump application.
- Capacity, delivery head, mains frequency 50 or 60Hz and other criteria can be used to select the best possible pumps for entire systems.
- Simulation of variable speed operation, with direct read-out of reduction of power consumption.
- Compare alternative solutions.
- Selection parameters are saved to consult later on or to manipulate afterwards.
- Substantial reduction of energy costs.

## FREQUENCY CONTROL

Pumps with fixed speed motors must be selected with the capacity to handle possible peak loads during extreme conditions. This implicates that most of the time the pump will be operating at very unfavorable efficiency conditions, resulting in an unnecessarily high energy consumption.

Frequency controlled electric motors save a large amount of energy by adjusting the motor speed according to the actual temperature measured in the greenhouse.

During extreme weather conditions frequency controlled motor drives can rev up the pumps to enable them to satisfy to the increased heat demand in the greenhouse sections.

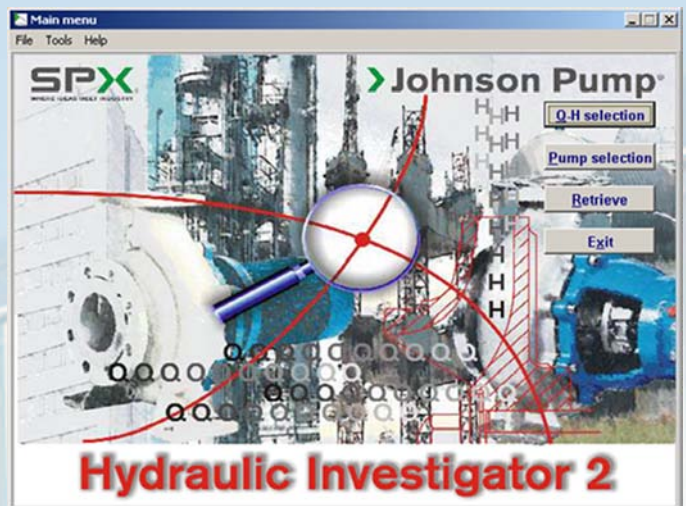

Reducing the motor speed of a centrifugal pump by 20% corresponds to a 20% reduction in flow, whereas the energy consumption will be reduced by as much as 50%. On yearly basis a substantial reduction in energy costs can be obtained.

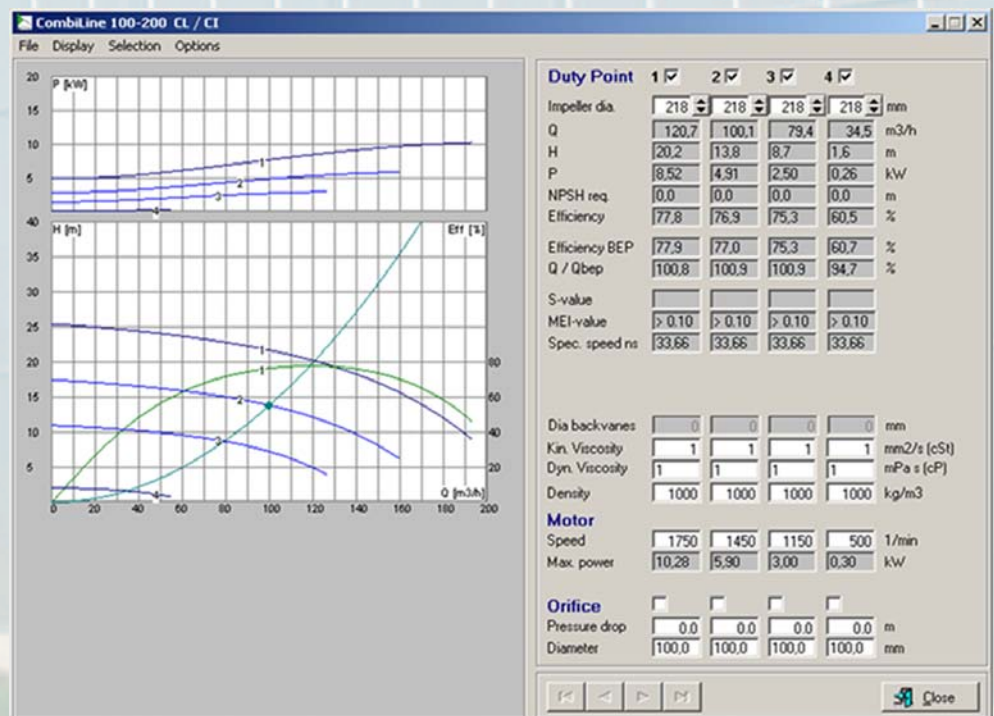

**Example:** CL 100-200 with 7.5 kW motor 50 Hz (8.6 kW at 60 Hz).

Capacity normal duty 100 m<sup>3</sup>/h, power consumption 4.91 kW, speed 1450 min<sup>-1</sup>, 50 Hz.

Peak load 120 m<sup>3</sup>/h, power consumption 8.52 kW, speed 1750 min<sup>-1</sup>, 60 Hz.

Off load duty 80 m<sup>3</sup>/h, power consumption 2.50 kW, speed 1150 min<sup>-1</sup>.

# Dimensions CL - CLB

ISO 7005 PN6				
N	O	P	R	S*T
32	78	90	140	4*14
40	80	100	130	4*14
50	90	110	140	4*14
65	110	130	160	4*14
80	128	150	190	4*18
100	148	170	210	4*18
ISO 7005 PN10				
N	O	P	R	S*T
32	78	100	140	4*18
40	88	110	150	4*18
50	102	125	165	4*18
65	122	145	185	4*18
80	138	160	200	8*18
100	158	180	220	8*18
125	188	210	250	8*18
150	212	240	285	8*18
200	268	295	340	8*23

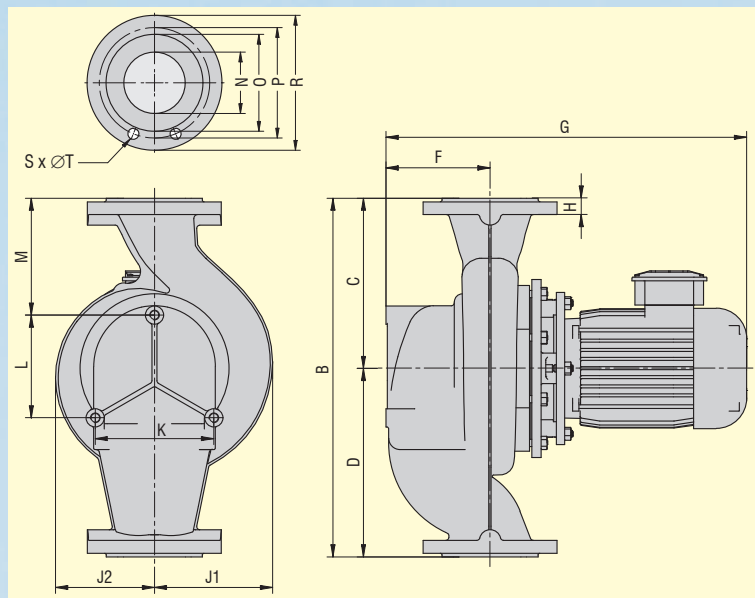

ISO 7005 ≅ EN 1092-2

External thread connection								
CL	Thread	B	C	D	F	H	J1	J2
CL 4/4	G 1 1/2"	180	90	90	31.5	9	69	62
CL 5/4	G 2"	180	90	90	31.5	9	69	62

PN6												
CL	B	C	D	F	H	J1	J2	K	L	M	N	
32-125	250	125	125	74	19	96	85	70	79	80	32	
40-125	250	125	125	79	18	96	85	92	85	75,5	40	
40-160	320	160	160	77	18	115	115	91	72,5	118,5	40	
40-200	360	180	180	76,5	18	141	141	93,5	105	124	40	
50-125	280	140	140	86	18	108	89	105	76,5	99	50	
50-160	340	170	170	87,5	18,5	120	115	107,5	85	127,5	50	
50-200	380	190	190	85,5	18,5	141	141	107	108,5	138,5	50	
65-125	340	170	170	115	18	120	100	127,5	101	121	65	
65-160	340	170	170	106,5	18	135	115	124	88,5	128,5	65	
80-125	360	180	180	130	20	143	109	143	124	118,5	80	
80-160	400	200	200	131	20,5	147	123	146,5	127	136,5	80	
100-150	560	280	280	148	18	194	145	105,5	116	239	100	
100-160	560	260	300	187,5	21	189	150	184,5	170	172,5	100	
100-200	590	280	310	171	27	195	163	195	169	192,5	100	

PN10												
CL	B	C	D	F	H	J1	J2	K	L	M	N	
32-125	250	125	125	74	19	96	85	70	79	80	32	
40-125	250	125	125	79	20	96	85	92	85	75,5	40	
40-160	320	160	160	77	20	115	115	91	72,5	118,5	40	
40-200	360	180	180	76,5	20	141	141	93,5	105	124	40	
50-125	280	140	140	86	22	108	89	105	76,5	99	50	
50-160	340	170	170	87,5	22,5	120	115	107,5	85	127,5	50	
50-200	380	190	190	85,5	22,5	141	141	107	108,5	138,5	50	
65-125	340	170	170	115	22	120	100	127,5	101	121	65	
65-160	340	170	170	106,5	22	135	115	124	88,5	128,5	65	
65-200	440	220	220	132,5	21	151	141	133,5	102,5	169,5	65	
80-125	360	180	180	130	24	143	109	143	124	118,5	80	
80-160	400	200	200	131	24,5	147	123	146,5	127	136,5	80	
80-200	530	265	265	113	22	170	143	151	139	192	80	
80A-250	590	280	310	214,5	27	200	176	195	169	175	100	
100-160	560	260	300	187,5	27	189	150	184,5	170	172,5	100	
100-200	590	280	310	171	27	195	163	195	169	192,5	100	
100A-250	730	355	375	224,5	28,5	237	202	225	195	241	125	
125-160	750	375	375	247	26	223	178	225	195	280	125	
125-200	750	375	375	247	26	223	178	225	195	280	125	
125A-250	805	355	450	282,5	28,5	261	216	310	254	212	150	
150-125	850	400	450	287	28,5	294	218	320	257,5	255	150	
150-160	750	315	435	287	28,5	257	200	310	230	175	150	
150-200	720	315	405	245	24,5	245	198	258	198,5	214	150	
150-250	850	400	450	283	28,5	279	227	320	257,5	255	150	
200-200	900	400	500	337	26,5	297	237	298	230,5	280	200	
CLB	B	C	D	F	H	J1	J2	K	L	M	N	
200-160	900	400	500	332	26,5	316	239	300	255	268	200	

# Dimensions CBH - CB

ISO 7005 PN16					
aa	ac	ae	ag	ai*ak	am
100	158	180	220	8*18	22
125	188	210	250	8*18	24
150	212	240	285	8*23	24
150	212	240	285	8*23	24
200	268	295	340	8*23	26
250	320	350	395	12*23	28

ISO 7005 PN10 (CBH 200-200)					
aa	ac	ae	ag	ai*ak	am
200	268	295	340	8*23	26

ISO 7005 PN16					
ab	ad	af	ah	aj*al	an
80	138	160	200	8*18	22
100	158	180	220	8*18	22
125	188	210	250	8*18	24
150	212	240	285	8*23	24
150	212	240	285	8*23	24
250	320	350	395	12*23	28

ISO 7005 PN10 (CBH 200-200)					
ab	ad	af	ah	aj*al	an
200	268	295	340	8*23	26

ISO 7005 ≅ EN 1092-2

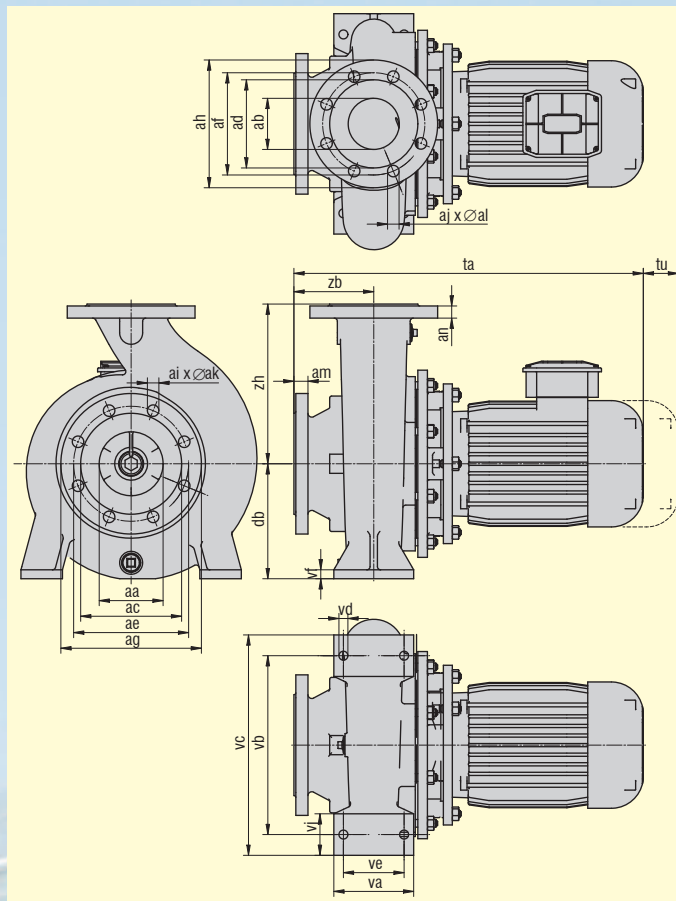

CBH	aa	ab	db	tu	va	vb	vc	vd	ve	vf	vj	zb	zh
80-200	100	80	180	140	125	280	345	14	95	14	65	125	250
80-250	100	80	200	140	160	315	400	18	120	15	80	125	280
100-160	125	100	200	100	160	280	360	18	120	15	80	125	315
100-200	125	100	200	140	160	280	360	18	120	15	80	125	280
100-250	125	100	225	140	160	315	400	18	120	16	80	140	280
125-250	150	125	250	140	160	315	400	18	120	18	80	140	355
150-125	150	150	280	140	160	315	400	18	120	18	80	160	400
150-160	150	150	250	100	160	315	400	18	120	18	80	160	315
150-200	150	150	250	140	160	315	400	18	120	18	80	160	315
150-250	200	150	280	140	200	400	500	23	150	20	100	160	400
200-200	200	200	280	100	200	400	500	23	150	22	100	200	400
250-200	250	250	315	140	200	450	550	23	150	22	100	200	450

CB	aa	ab	db	tu	va	vb	vc	vd	ve	vf	vj	zb	zh
125-125	125	125	225	100	125	250	320	14	95	14	65	140	300
125-315	150	125	280	140	200	400	500	23	150	20	100	140	355
200-160	200	200	280	140	200	400	500	23	150	22	100	200	400
250-200	250	250	315	140	200	450	550	23	150	22	100	200	450

Motor	90L	100L	112M	132S	132M	132M*	160M	160L	160L**	180M	180L	200L
<b>CBH</b>	ta											
80-200	514	544	561	638	676							
80-250		543	560	638	676	693		810				
100-160		544	561	638	676							
100-200		544	561	638	676	693						
100-250		558	575	653	691	708		825				
125-250			575		691	708		825	851			
150-125		569	586									
150-160		579	596	673	711	728						
150-200			596	673	711	728						
150-250						728		845	871			
200-200					751	768		885	911			
250-200						768		885	911			
<b>CB</b>	ta											
125-125	618	662	688	766			894					
125-315				802	840		930	974		1008	1044	1136
200-160		737	763	841	879		969					
250-200				848	886		976	1020		1054	1090	1202

\* 4 poles 9.2 and 11kW / 6 poles 5.5 and 7.5 kW, \*\* 4 poles 18.5 and 22 kW



### **SPX FLOW TECHNOLOGY ASSEN B.V.**

#### **SALES OFFICE HORTICULTURE**

De Hondert Margen 23

2678 AC, De Lier

The Netherlands

TEL +31 (0)174 518 410

FAX +31 (0)174 518 444

EMAIL: [johnson-pump.horticulture@spx.com](mailto:johnson-pump.horticulture@spx.com)

[www.johnson-pump.com/horticulture](http://www.johnson-pump.com/horticulture)

### **SPX FLOW TECHNOLOGY ASSEN B.V.**

Dr. A.F. Philipsweg 51, 9403 AD Assen

P.O. Box 9, 9400 AA Assen, THE NETHERLANDS

P: +31 (0)592 37 67 67

F: +31 (0)592 37 67 60

E: [johnson-pump.nl@spx.com](mailto:johnson-pump.nl@spx.com)

SPX reserves the right to incorporate our latest design and material changes without notice or obligation.

Design features, materials of construction and dimensional data, as described in this bulletin, are provided for your information only and should not be relied upon unless confirmed in writing. Please contact your local sales representative for product availability in your region. For more information visit [www.spx.com](http://www.spx.com) and [www.johnson-pump.com](http://www.johnson-pump.com).

The green ">" is a trademark of SPX Corporation, Inc..

JP\_401\_GB Version: 01/2013 Issued: 08/2013

COPYRIGHT © 2005, 2011, 2013 SPX Corporation