

SHD

Pompy specjalistyczne monoblokowe z wirnikiem zamkniętym SHD

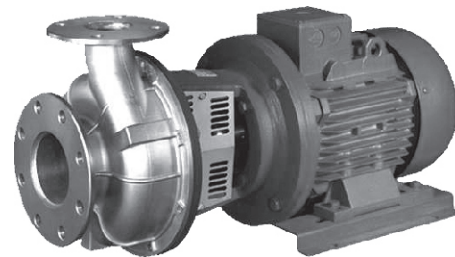

PRZEZNACZENIE

Pompy SHD to pompy wirowe jednostopniowe wyposażone w wirnik zamknięty. Przeznaczone są do pompowania cieczy chemicznych lub płynów zawierających niewielki procent ciał stałych w zawiesinie. Wyposażone mogą one być w jedno z wielu rodzajów uszczelnień mechanicznych albo sznurowych, co pozwala je stosować również w trudnych technologicznie przypadkach. Część hydrauliczna wykonana jest ze stali nierdzewnej, co czyni pompę odporną chemicznie na większość mediów.

ZAKRES UŻYTKOWANIA

Wydajność	do 300 m ³ /h
Wysokość podnoszenia	do 60 m
Ciśnienie robocze	do 0,6 MPa
Średnica przyłączy	25 do 80 DN
Moc silnika	do 22 kW
Temperatura czynnika	-20 do 120°C

CECHY KONSTRUKCYJNE

część hydrauliczna

- pompa odśrodkowa jednostopniowa,
- ssanie w osi poziomej, tłoczenie pionowo w górę,
- wał pompy połączony z wałkiem silnika przy pomocy sprzęgła sztywnego,
- uszczelnienie mechaniczne lub sznurowe,
- zróżnicowane wykonanie:
 - z przyłączem kołnierzowym SHD,
 - z przyłączem gwintowanym SHD A,

silnik

- 2 lub 4-biegunowy,
- silniki w klasie sprawności IE2 lub IE3,
- z krótkim wałem,
- napięcie 3x400-415V, 50Hz,
- kierunek obrotów w prawo (patrząc od strony przewietrznika),
- stopień ochrony IP55.

ZALETY

- znormalizowane wymiary,
- modułowa budowa,
- niskie koszty wytworzenia,
- krótkie terminy realizacji,
- możliwość współpracy z przetwornicą zewnętrzną,
- duża niezawodność,
- rozbudowany typoszereg,
- wysokie sprawności i niskie NPSH,
- możliwość nietypowego zasilania np. 3x500V, 60Hz,
- dostępność i szybkość serwisowania,
- dostępność wykonania przeciwwybuchowych zgodnie z ATEX.

POMPY SPECJALISTYCZNE

KLUCZ OZNACZEŃ

	SH	D	A	32	-	16	A	C	122	.3	5,5 / 2900	XX
Oznaczenie typoszeregu												
Typ wirnika - D - zamknięty												
Rodzaj przyłącza: bez oznaczenia - kołnierzone A - gwintowane												
Średnica króćca tłoczego												
Wielkość pompy												
Wielkość wirnika												
System uszczelnienia: - bez oznaczenia - mechaniczne pojedyncze - L - mechaniczne podwójne tamdem - A i H - mechaniczne z komorą grzewczą/chłodzącą - C - mechaniczne podwójne back to back - B - sznurowe - F - sznurowe z zewnętrznym płukaniem												
Kod materiału uszczelnienia												
Wykonanie materiałowe - 3 - ANSI316												
Moc silnika [kW]												
Obroty silnika - 2900 min ⁻¹ - 1450 min ⁻¹ - 950 min ⁻¹												
Inne dodatkowe dane												

Opis	Jednostka miary	Typ pompy											
		25-16	25-19	32-16	40-16	50-16	32-20	40-20	50-20	65-16	80-16	65-20	80-20
Wielkość korpusu łożyskowego		1				2				3			
Korpus													
Grubość ścianki korpusu	mm	4	4	4	4	4	4,5	4,5	4,5	4,5	5	5	5
Otwór pod manometr	bar	6				8				6	6	8	
Otwór spustowy		G.1/4				G.1/4				G.1/4			
Wirnik													
Ilość łopatek	mm	5	5	5	5	6	5	5	5	6	6	6	6
Szerokość wirnika	mm	6	6	6	8,5	13,5	6	7	11	19	27	16	21
Średnica wlotowa	mm	56	56	67	67	83	58	68	82	65	80	100	65
Maksymalna średnica wirnika	mm	169	190	169	169	169	209	209	209	169	169	209	209
Minimalna średnica wirnika	mm	110	170	110	110	110	140	140	140	130	130	150	150
Moment bezwładności *	kgm ²	0,01	0,01	0,01	0,01	0,01	0,02	0,02	0,02	0,01	0,01	0,02	0,02
Komora dławnicy sznurowej													
Średnica	mm	40				49				49			
Głębokość	mm	45				51				51			
Przekrój szczeliwa	mm	8				8				8			
Ilość pierścieni płuczających		4				5				5			
Ilość pierścieni niepluczających		5				6				6			
Średnica uszczelnienia mechanicznego	mm	24				33				33			
Otwory przyłączeniowe hydr. do dław. sznurowej		G.1/4				G.1/4				G.1/4			
Otwory przyłączeniowe hydr. do dław. mech.		G.1/4				G.1/4				G.1/4			
Płaszcz chłodzący													
Maksymalne ciśnienie	bar	3				3				3			
Maksymalne ciśnienie hydrostatyczne	bar	4,5				4,5				4,5			
Otwory przyłączeniowe hydrauliczne		G.3/8				G.3/8				G.3/8			
Wałek													
Średnica wałka	mm	24				33				33			
Średnica wałka pod wirnikiem	mm	20				20				28			
Maksymalna moc													
Maksymalna wartość P/n		0,0052				0,0064				0,0076			
Maksymalna moc przy n=960min ⁻¹	kW	5				6				7,3			
Maksymalna moc przy n=1450min ⁻¹	kW	7,5				9,2				11			
Maksymalna moc przy n=2900min ⁻¹	kW	15				18,5				22			

Dane techniczne są orientacyjne i mogą ulec zmianie podczas pracy pompy.

*/ aby otrzymać moment bezwładnościowy J [kgm²] należy podzielić przez 1000.

POMPY SPECJALISTYCZNE

Ograniczenia ciśnienia i temperatury

(bez szczególnych wymagań)

Odpowiednie dla każdego rodzaju cieczy, oprócz gorącej wody i organicznych olejów przenoszących ciepło.

Wykonanie materiałowe:

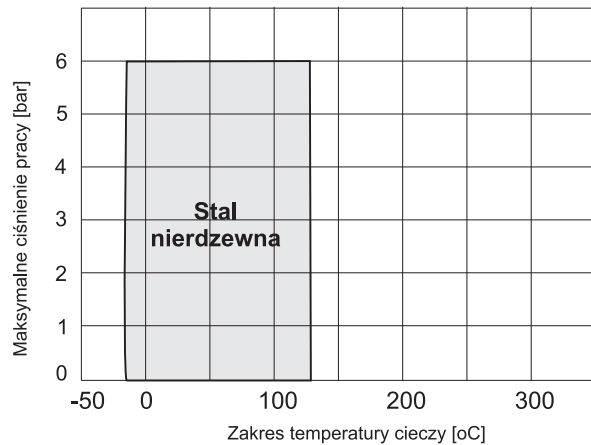

Wyk. materiałowe	Temperatura	Ciśnienie
stal nierdzewna	-20 +120	6 Bar

Wykonanie materiałowe na życzenie : Sanicro, SAF

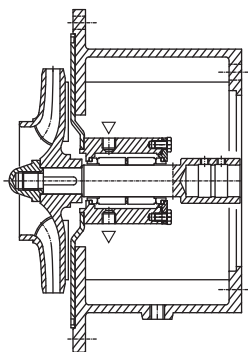

Uszczelnienie typu C

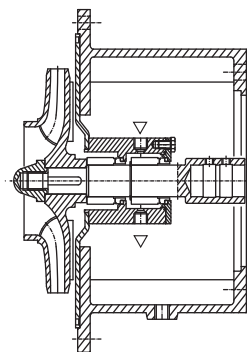

Uszczelnienie typu L

Płukanie podwójnego uszczelnienia mechanicznego dla wykonania C i L.

Wielkość korpusu łożyskowego [mm]	Średnica uszczelnienia mechanicznego [mm]	Wydajność płukania (przepływu) [l/min]		Ciśnienie przepływu [bar]	
		2900 min ⁻¹	1450 min ⁻¹	C	L
1	24	0,8	0,4	0.5 > ciśnienia na wlocie pompy	< 0.3
2-3	33	1,4	0,7		

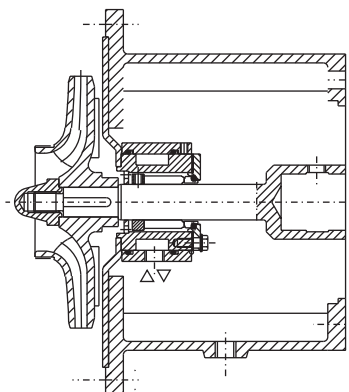

Uszczelnienie typu H

Płukanie komory chłodzącej dla wykonania H

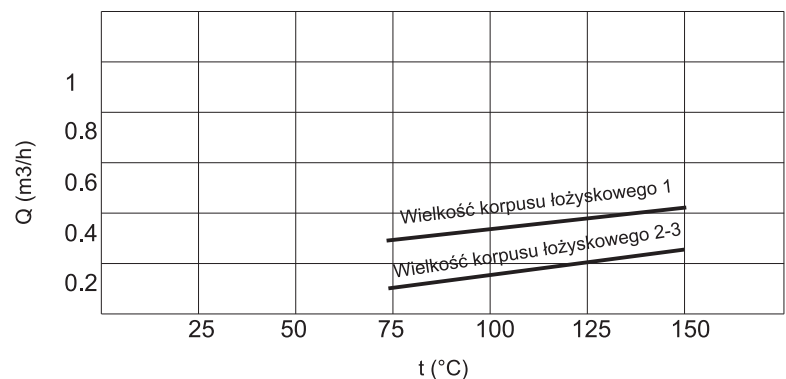

BUDOWA

Budowa pomp SHD z przyłączem kołnierzowym i SHD A z przyłączem gwintowanym

Pompy SHD (A) 25-16, SHD (A) 25-19, SHD (A) 32-16, SHD (A) 32-20, SHD (A) 40-16, SHD (A) 40-20, SHD (A) 50-16, SHD (A) 50-20

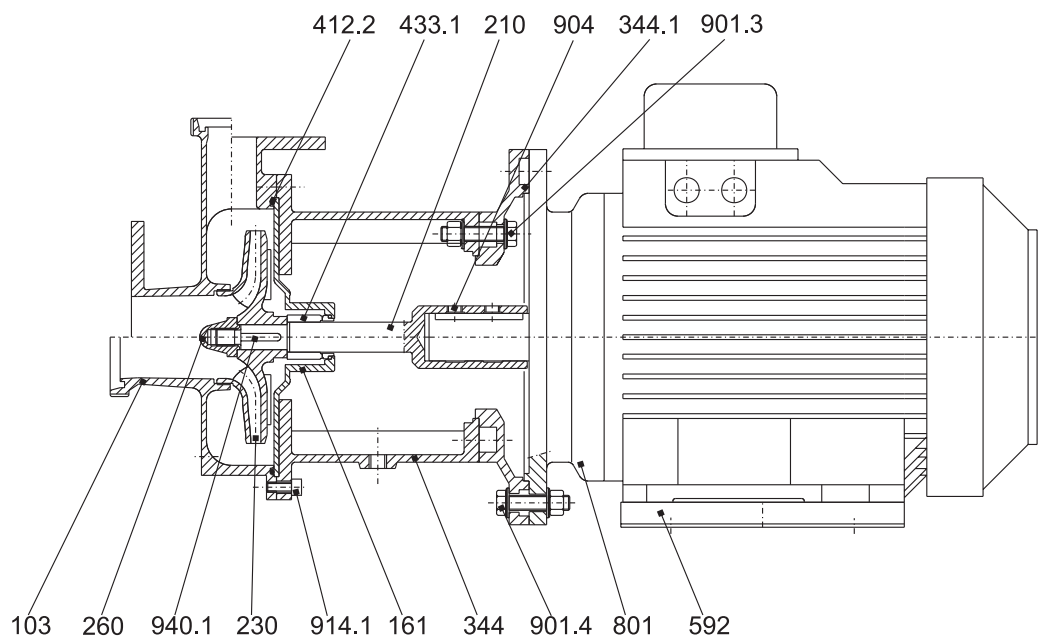

Pompy SHD (A) 65-16, SHD (A) 65-20, SHD (A) 80-16, SHD (A) 80-20

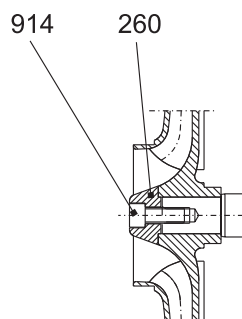

- 103 korpus
- 161 pokrywa
- 210 wał pompy
- 230 wirnik
- 260 nakrętka wirnika
- 344 łącznik
- 344,1 kołnierz redukujący
- 412,2 o-ring
- 433,1 uszczelnienie mechaniczne
- 592 podstawa silnika
- 801 silnik elektryczny
- 901,3 śruba z łbem sześciokątnym
- 901,4 śruba z łbem sześciokątnym
- 904 śruba dociskowa
- 914 śruba
- 914,1 śruba
- 940,1 wpust wirnika

POMPY SPECJALISTYCZNE

USZCZELNIENIA - DŁAWNICE

Uszczelnienie standardowe mechaniczne pojedyncze

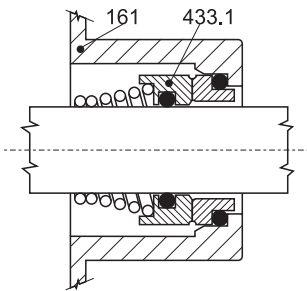

Uszczelnienie typu C mechaniczne podwójne back to back

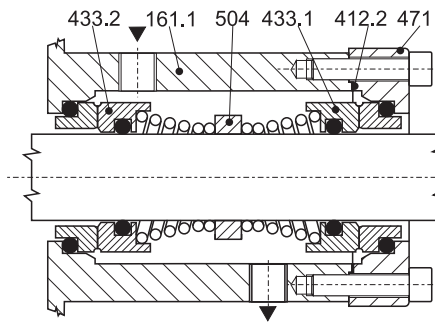

Uszczelnienie typu L mechaniczne podwójne szeregowe (tandem)

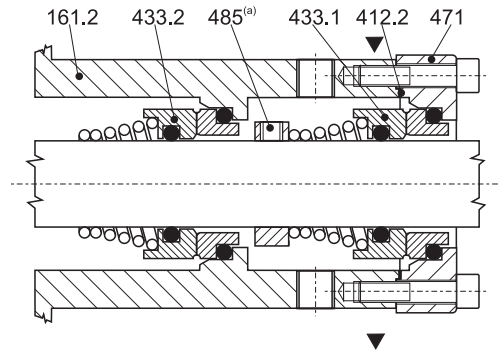

Uszczelnienie typu A i H mechaniczne z komorą grzewczą/chłodzącą

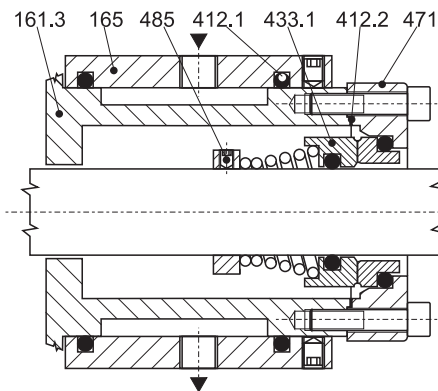

Uszczelnienie typu F sznurowe z zewnętrznym płukaniem

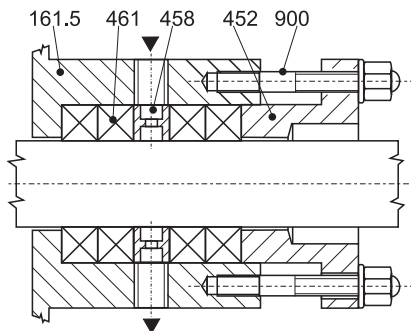

Uszczelnienie typu B sznurowe

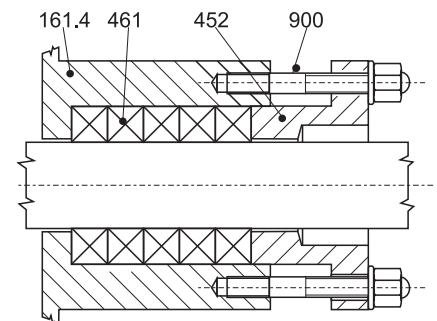

- 161 pokrywa pompy
- 161,1 pokrywa pompy - uszczelnienia typu C
- 161,2 pokrywa pompy - uszczelnienia typu L
- 161,3 pokrywa pompy - uszczelnienia typu A i H
- 161,4 pokrywa pompy - uszczelnienia typu B
- 161,5 pokrywa pompy - uszczelnienia typu F
- 165 pokrywka uszczelniająca
- 412,1 o-ring
- 412,2 o-ring
- 433,1 uszczelnienie mechaniczne
- 433,2 uszczelnienie mechaniczne
- 452 dławik
- 458 pierścień płuczący
- 461 krążek szczeniwa
- 471 pokrywka dławnicy mechanicznej
- 485 pierścień oporowy
- 504 pierścień dystansowy
- 900 śruba dwustronna z nakrętką

CHARAKTERYSTYKI POMP

$n=1450\text{min}^{-1}$

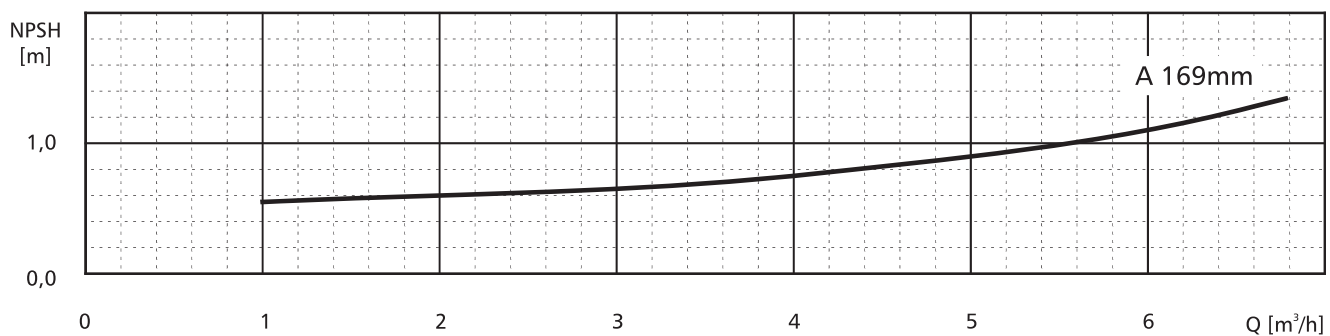
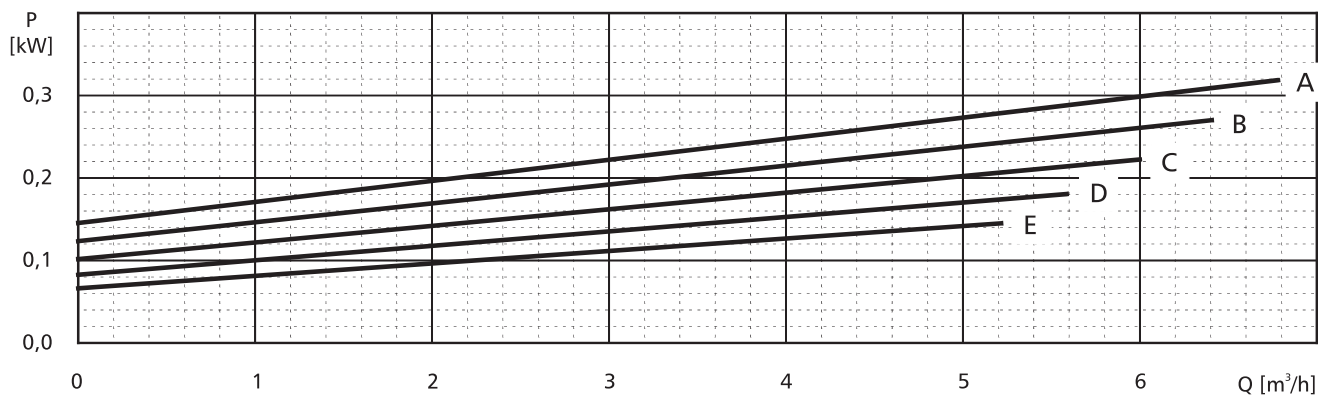
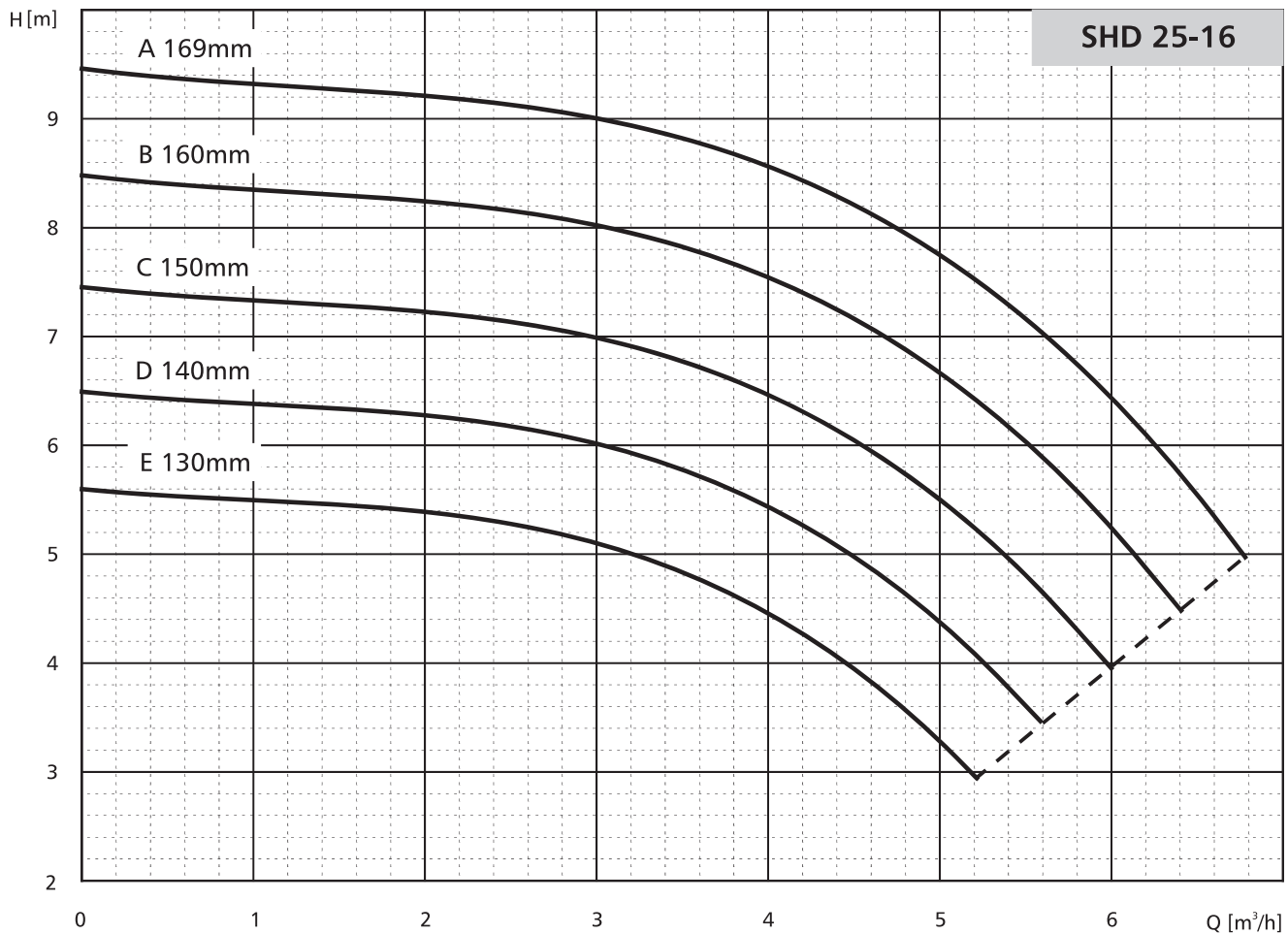

$n=1450\text{min}^{-1}$

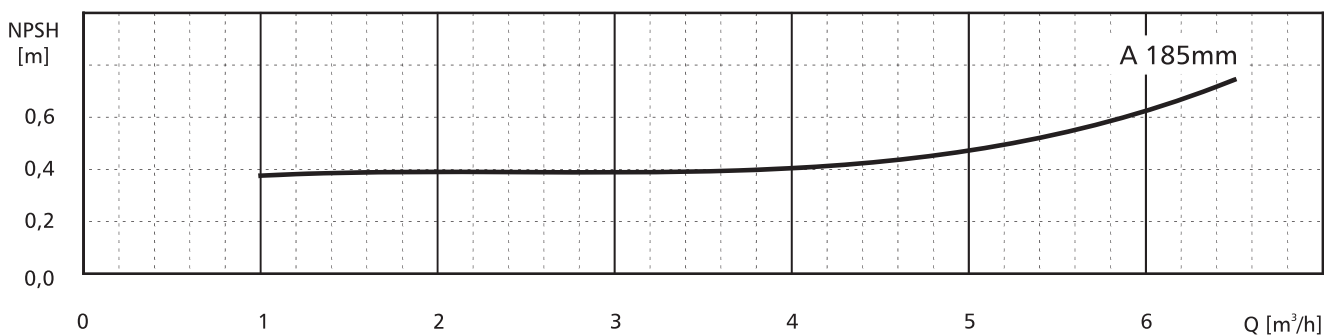
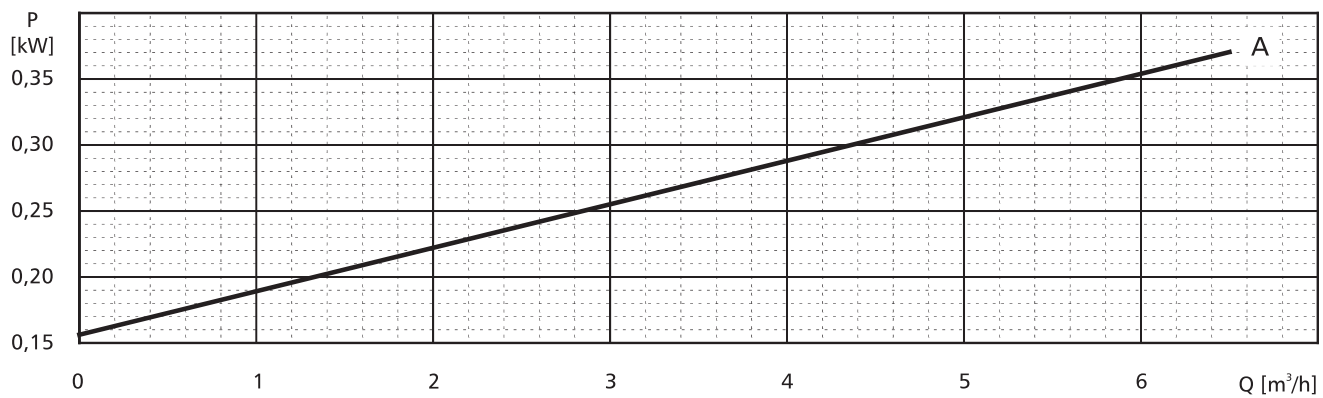
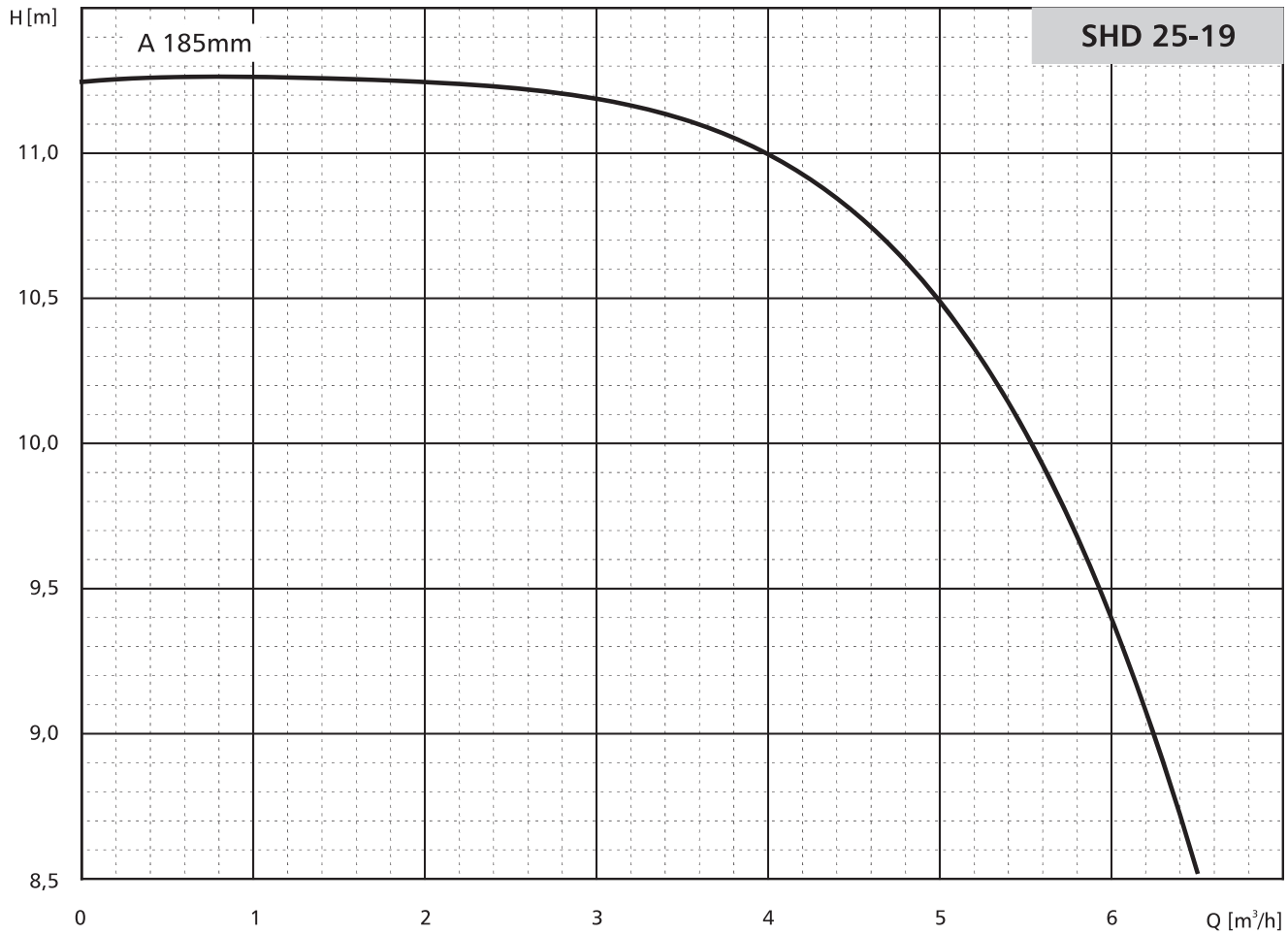

$n=1450\text{min}^{-1}$

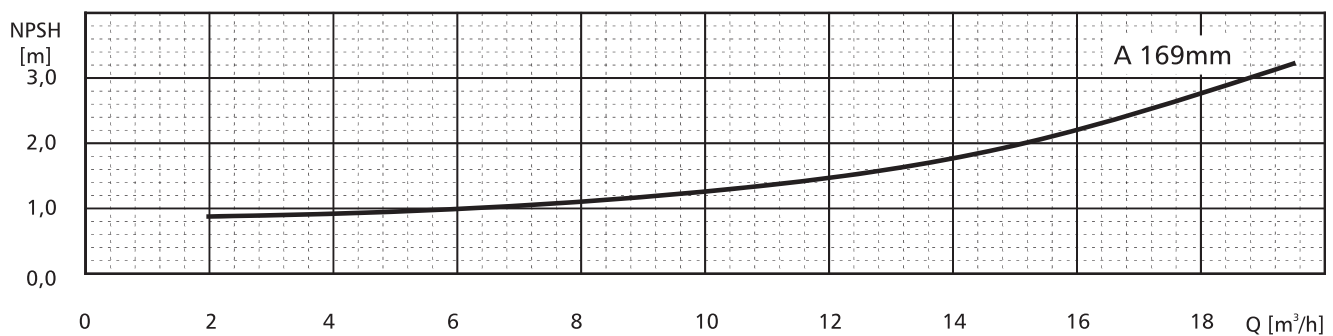
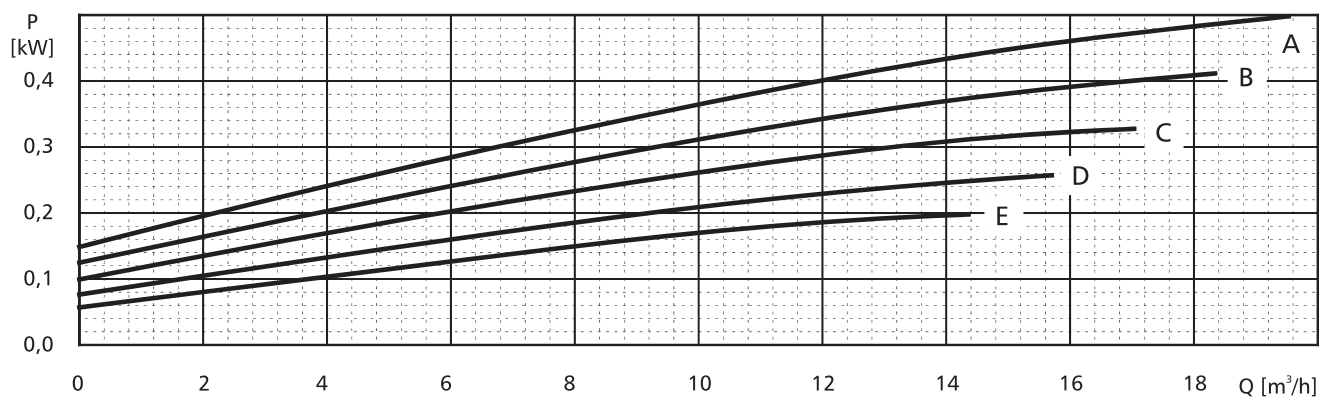
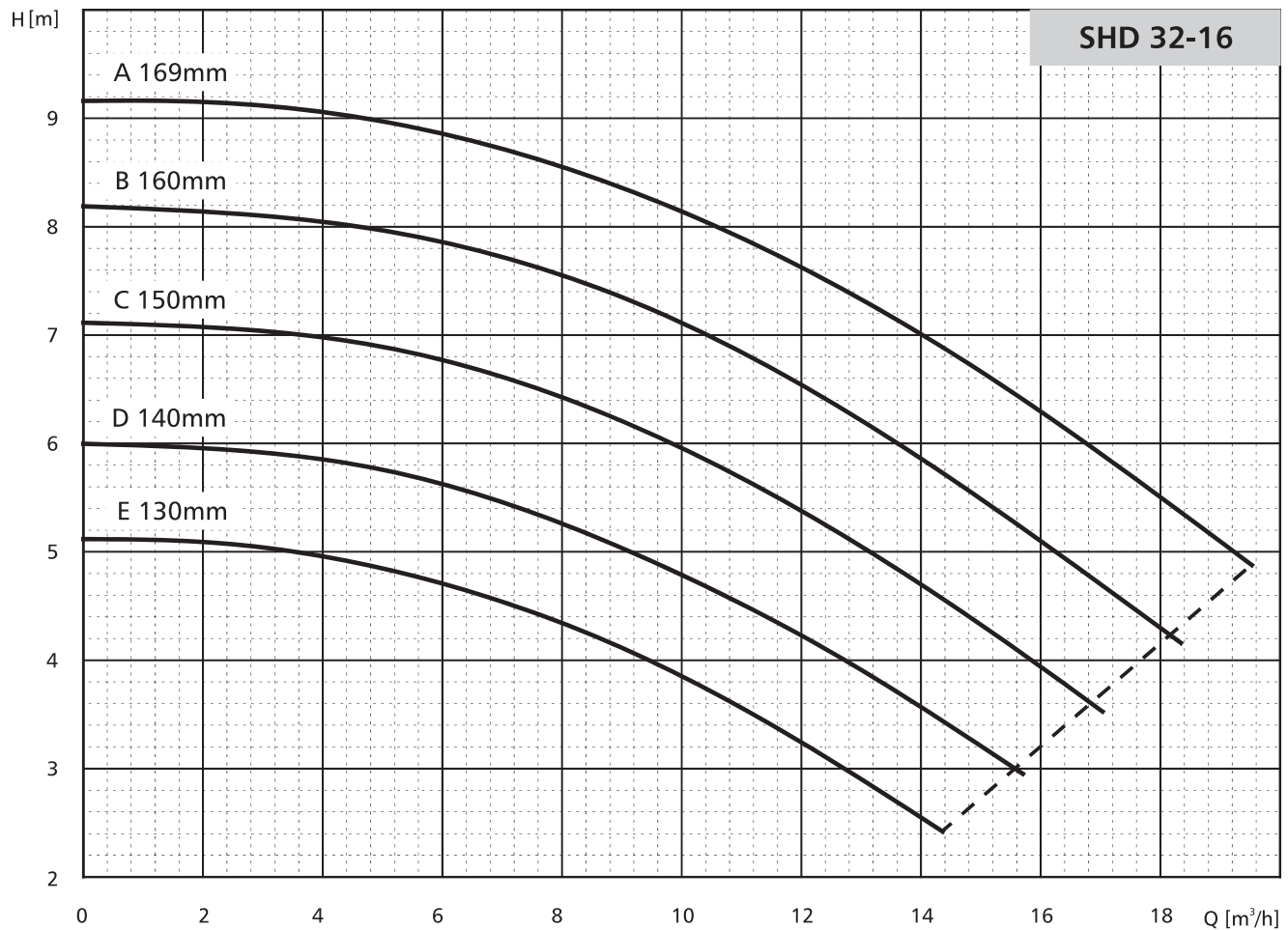

$n=1450\text{min}^{-1}$

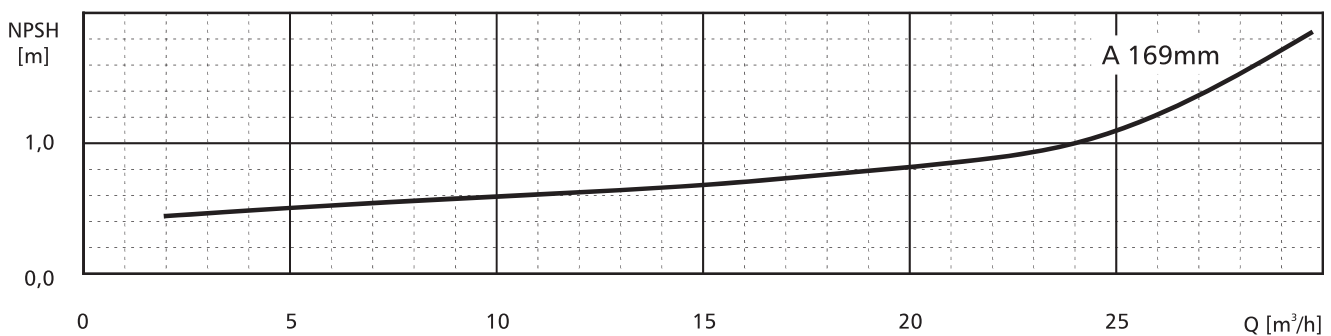
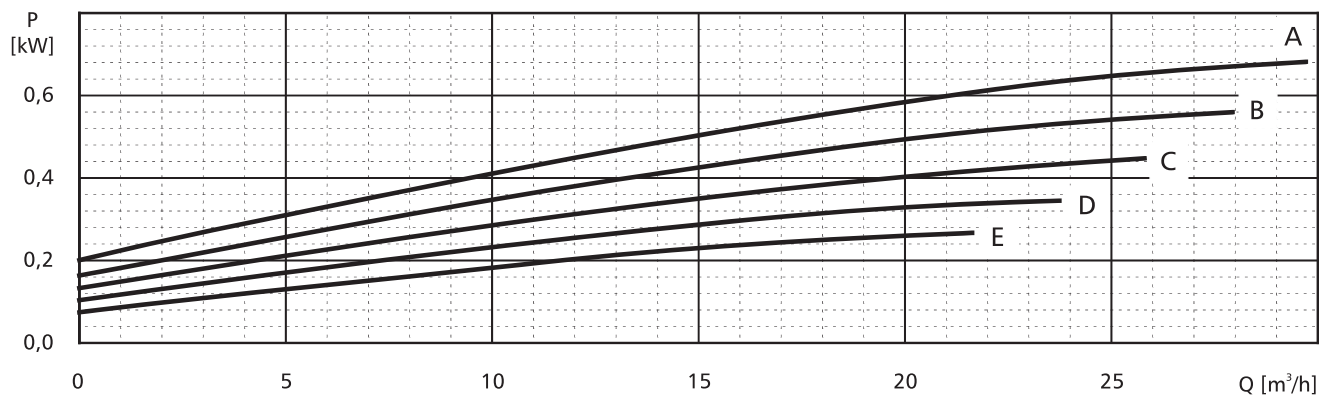
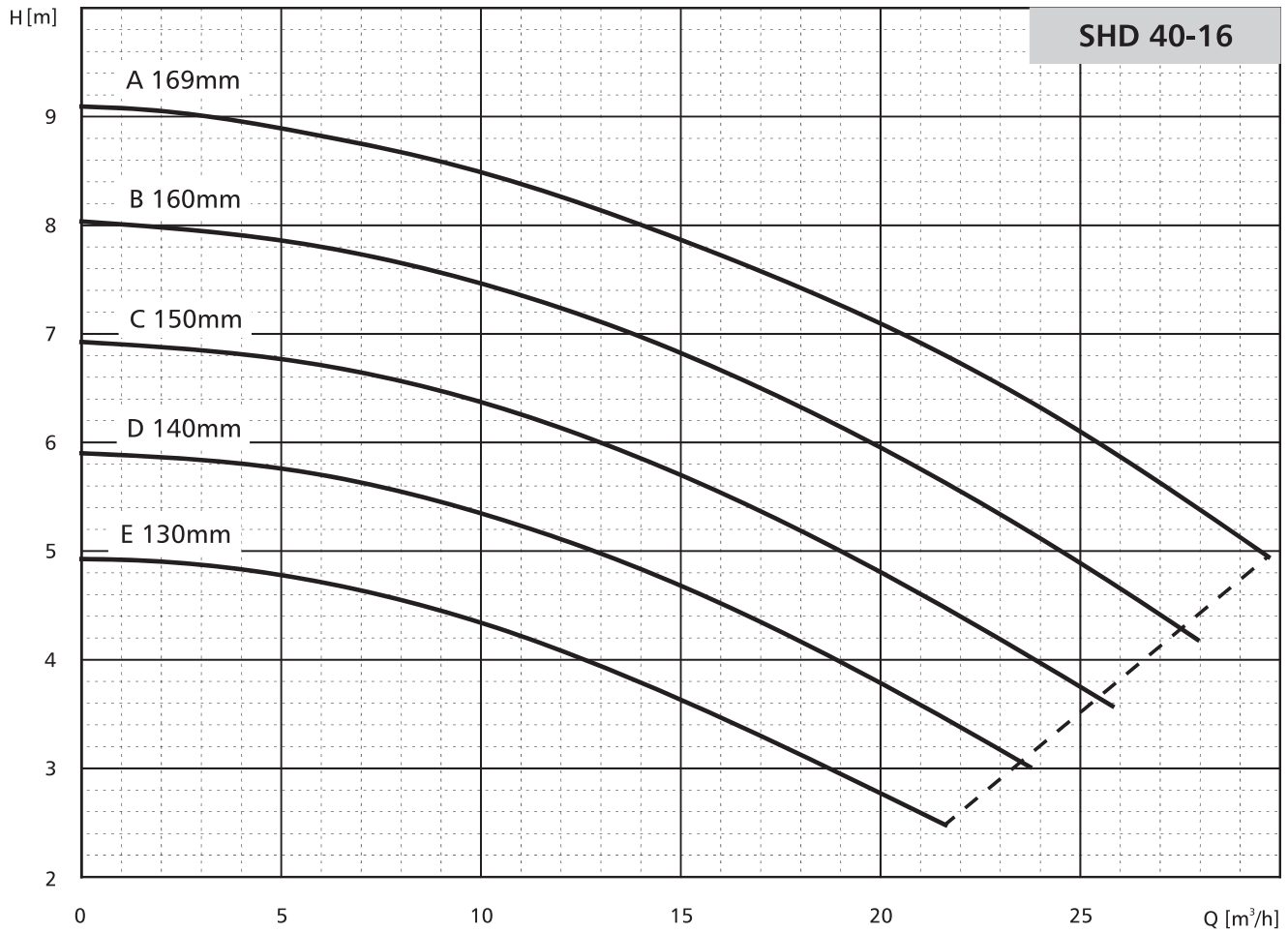

$n=1450\text{min}^{-1}$

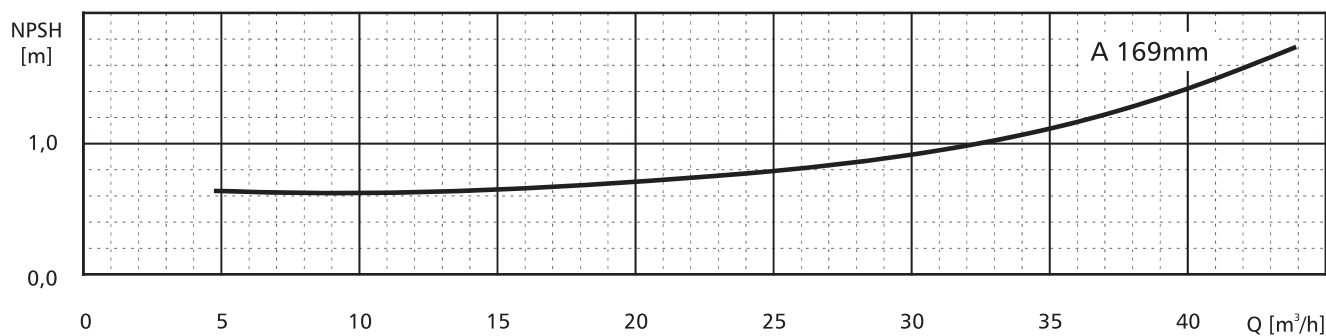
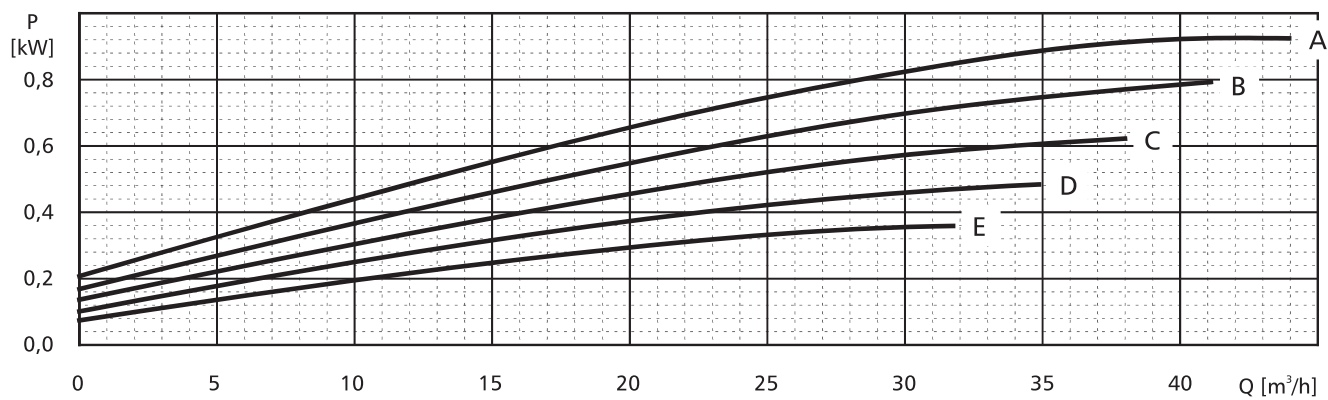
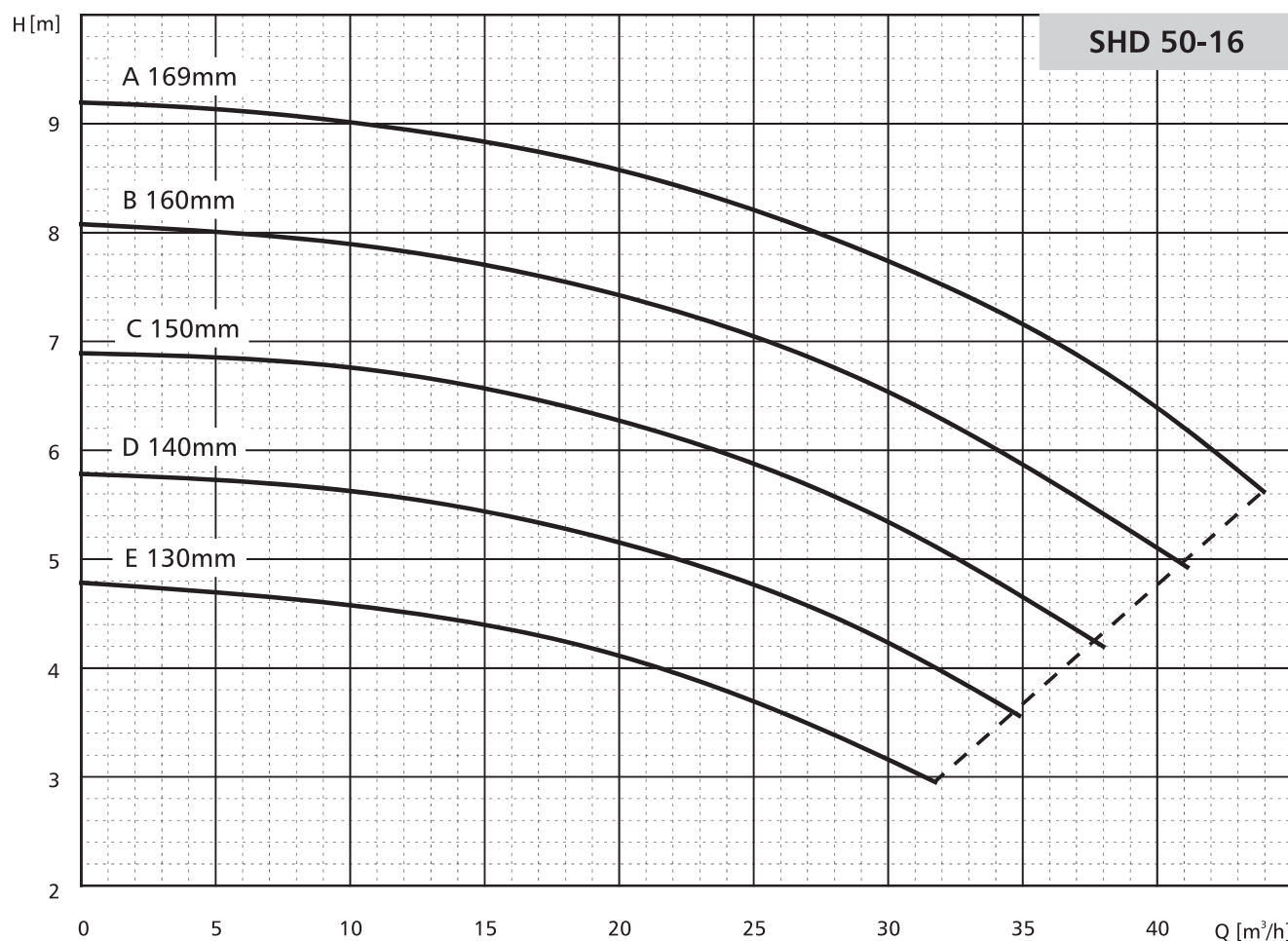

$n=1450\text{min}^{-1}$

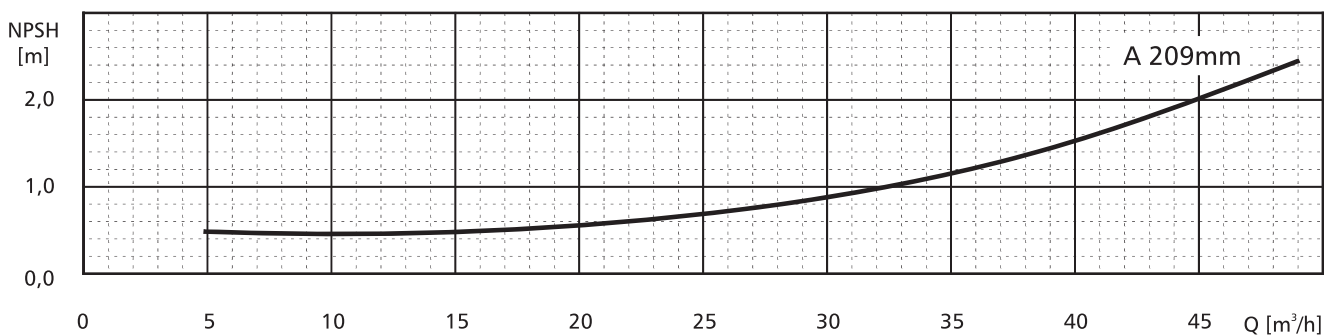
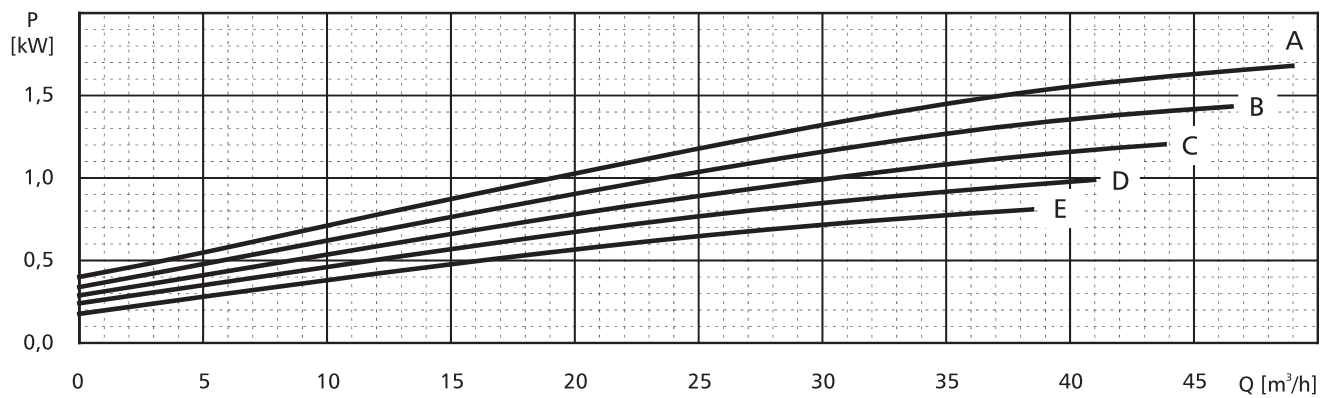
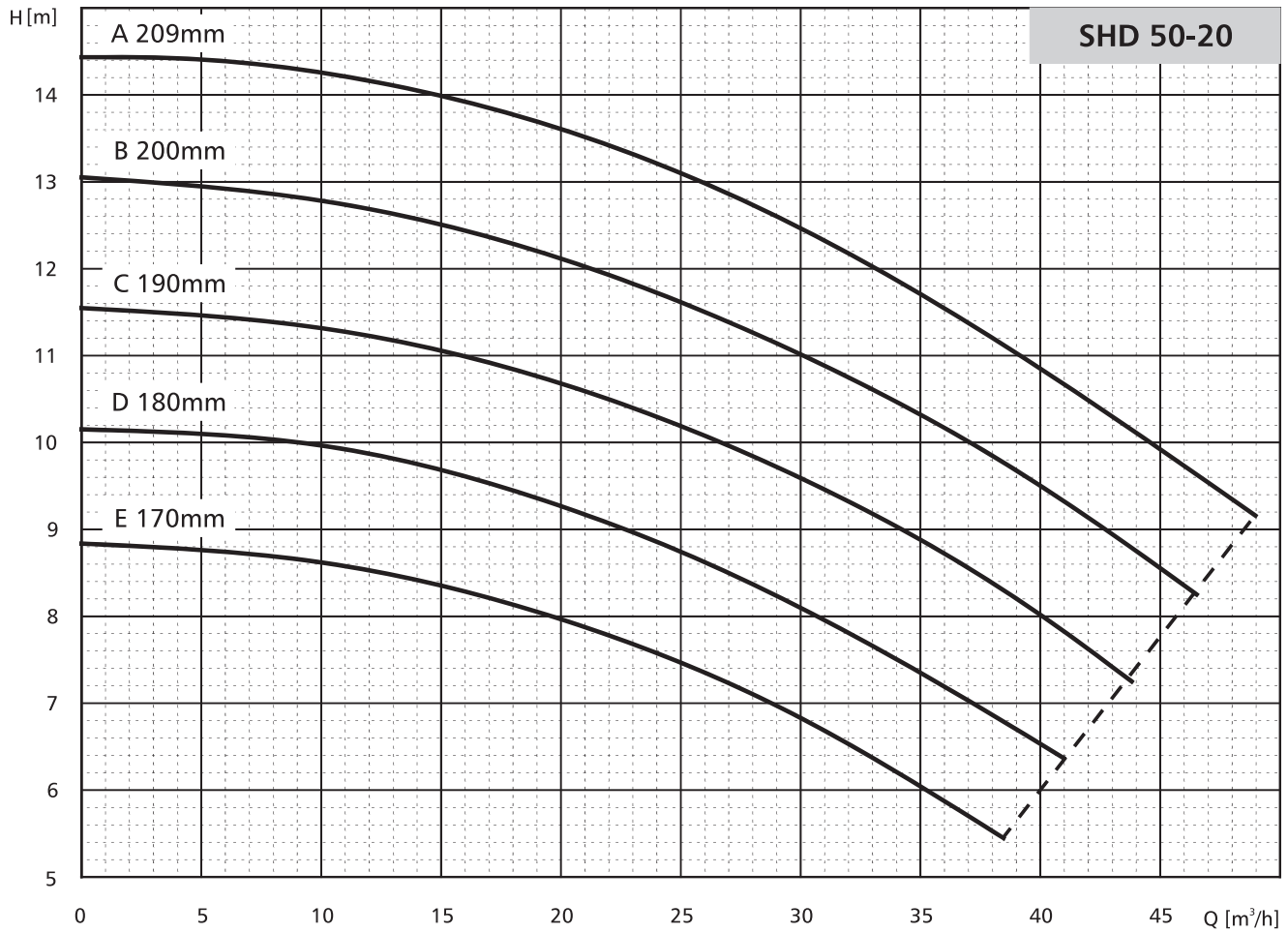

$n=1450\text{min}^{-1}$

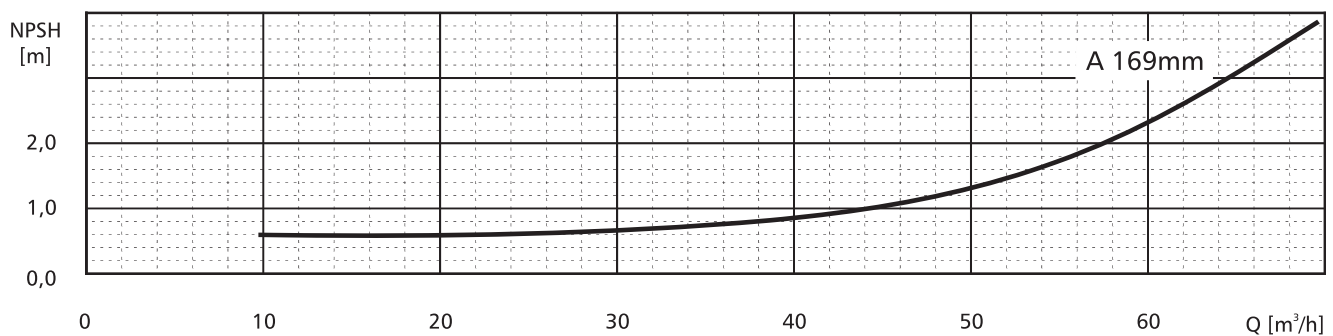
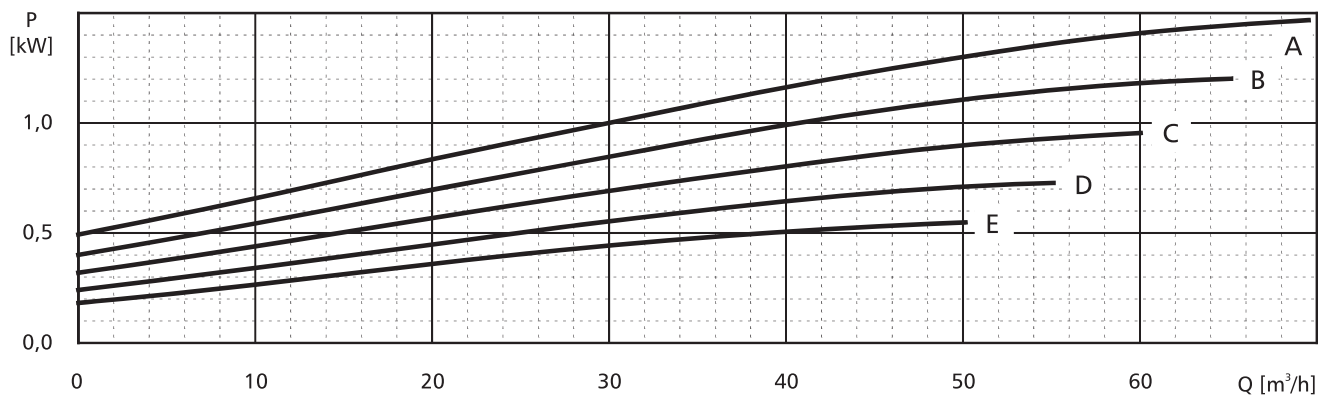
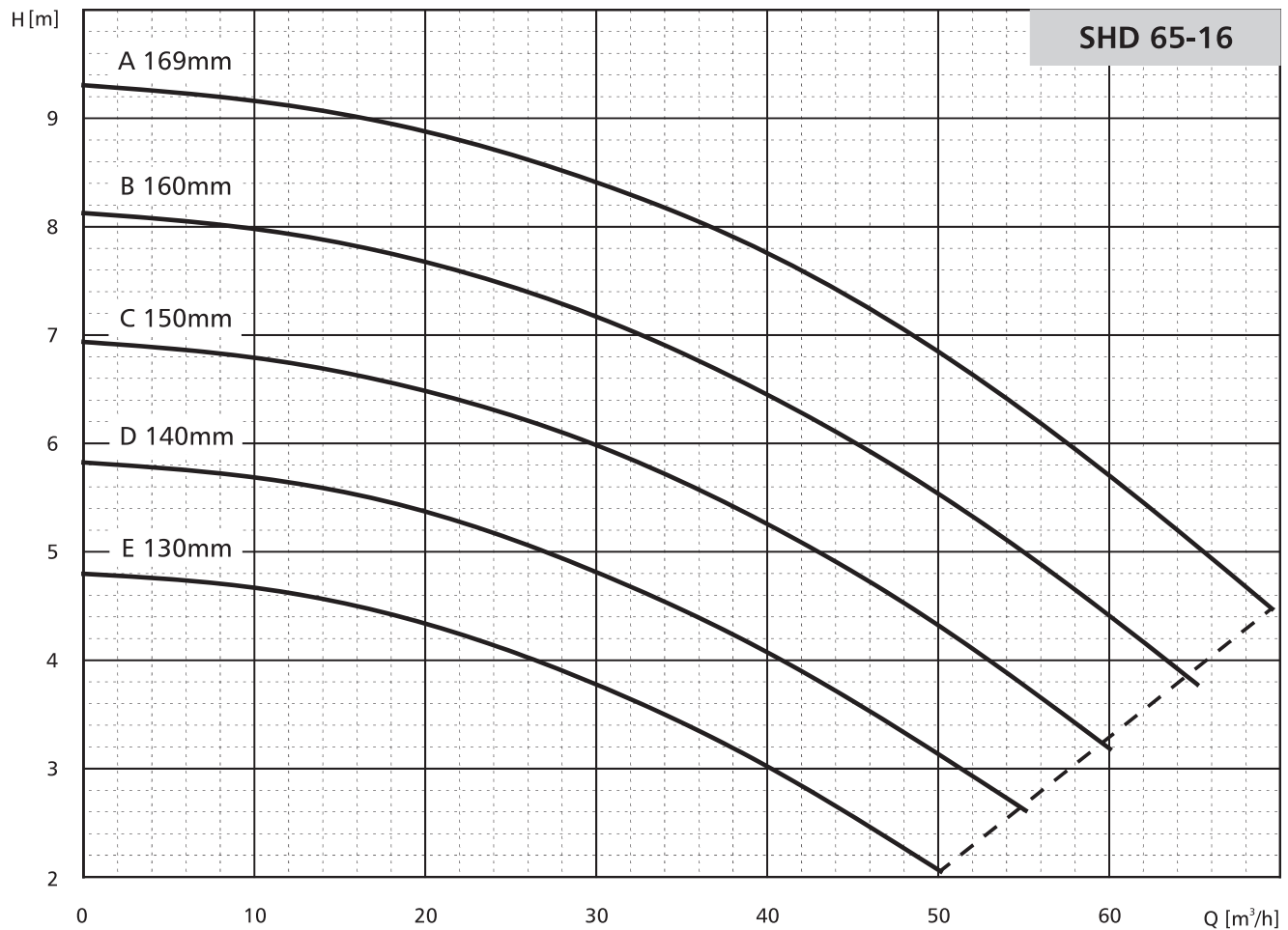

POMPY SPECJALISTYCZNE

$n=1450\text{min}^{-1}$

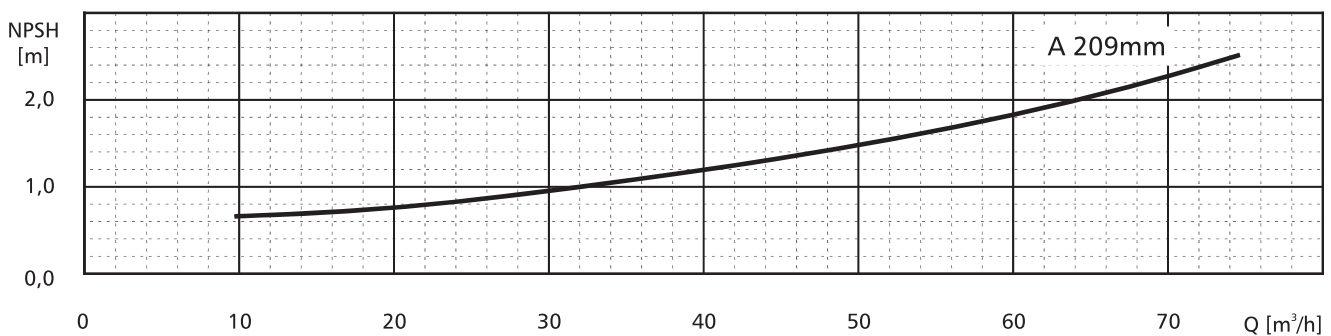
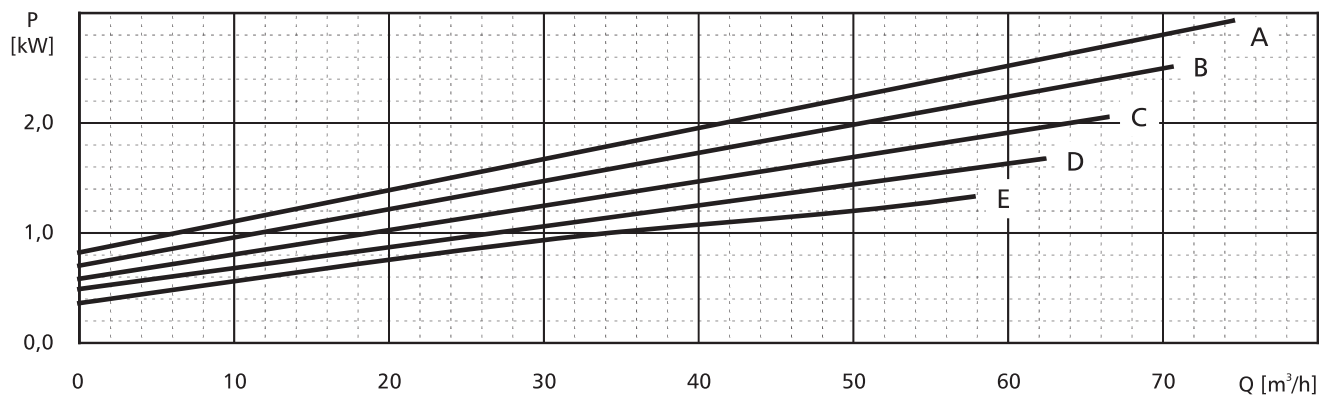
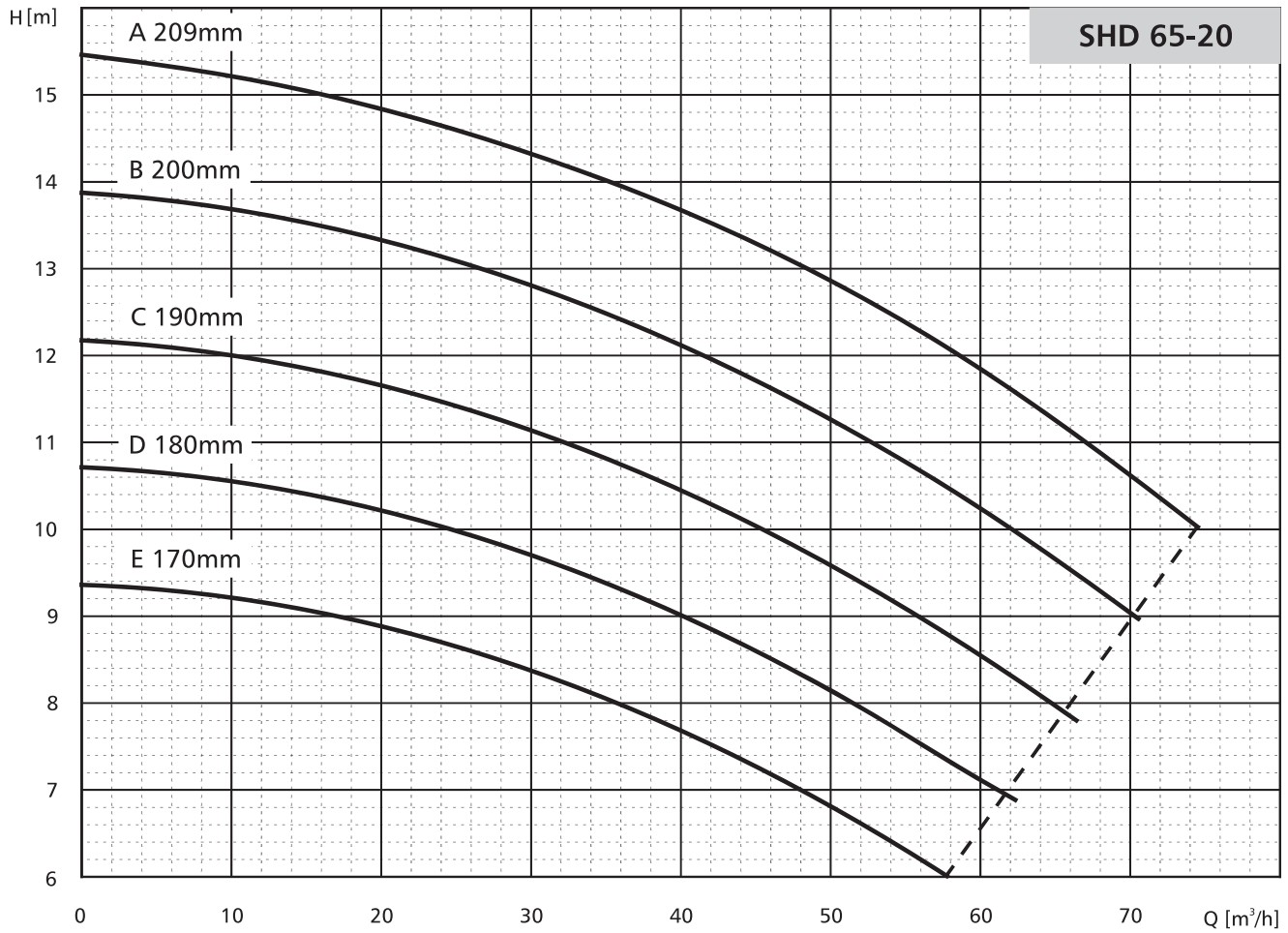

$n=1450\text{min}^{-1}$

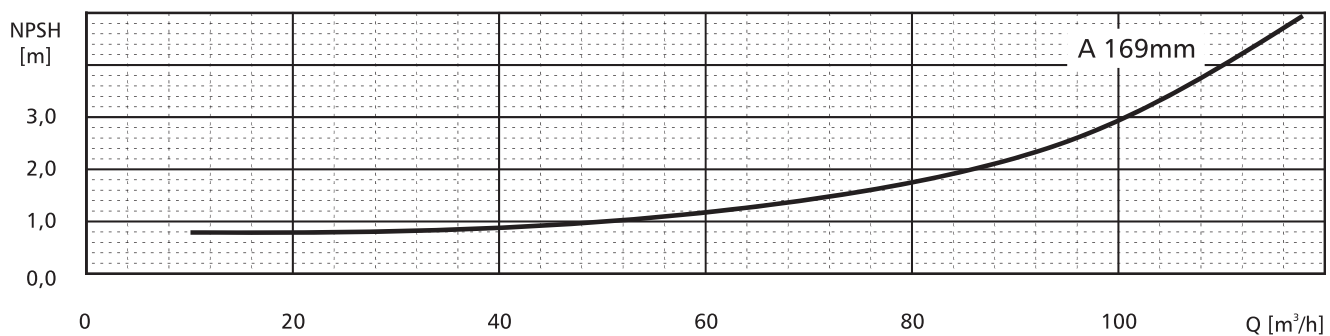
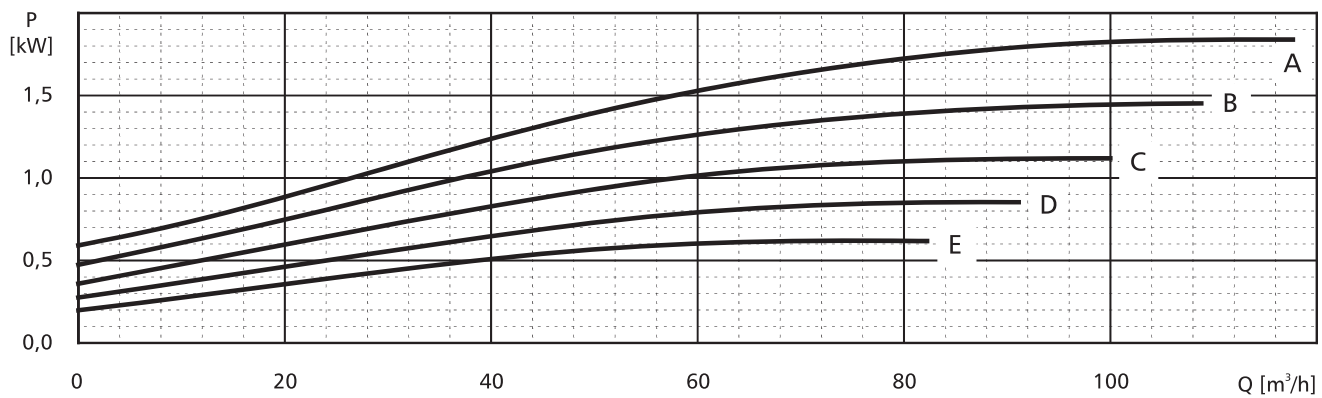
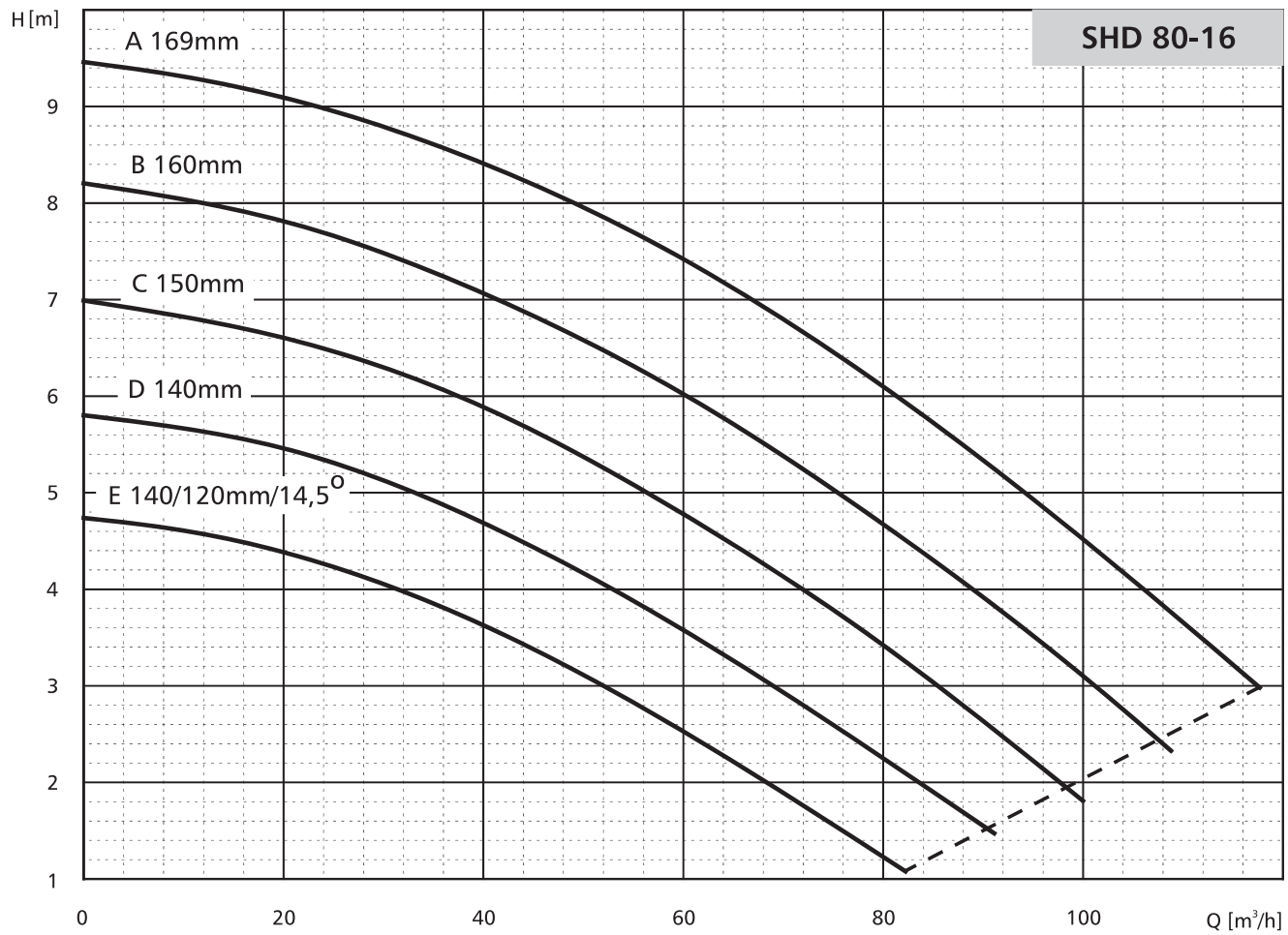

$n=1450\text{min}^{-1}$

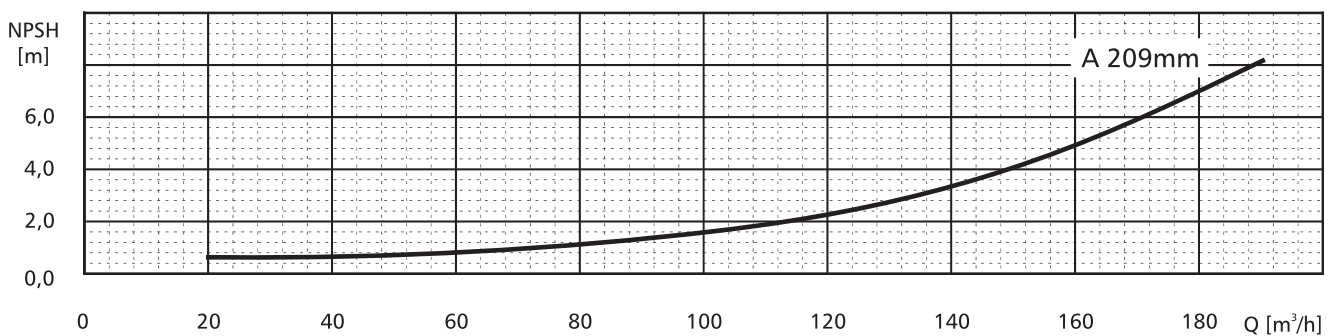
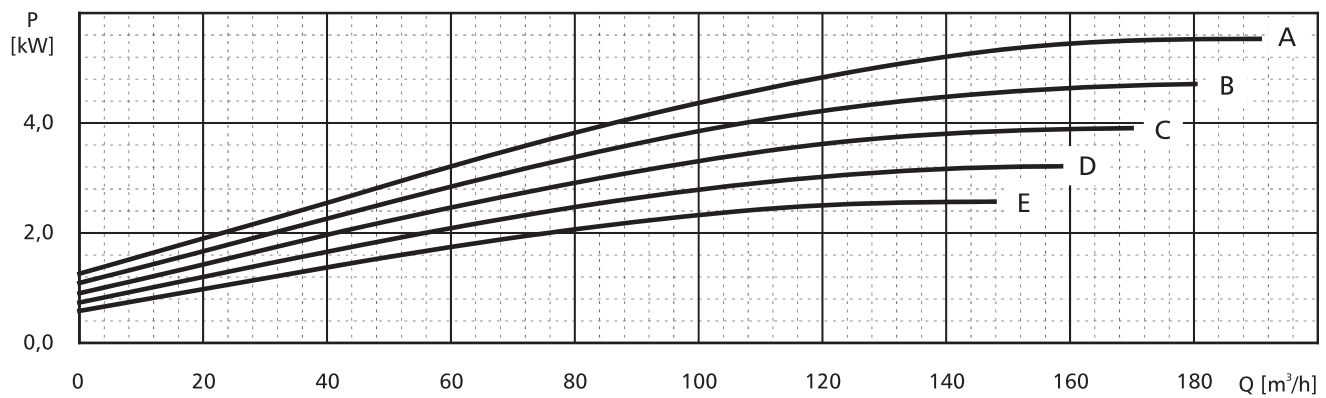
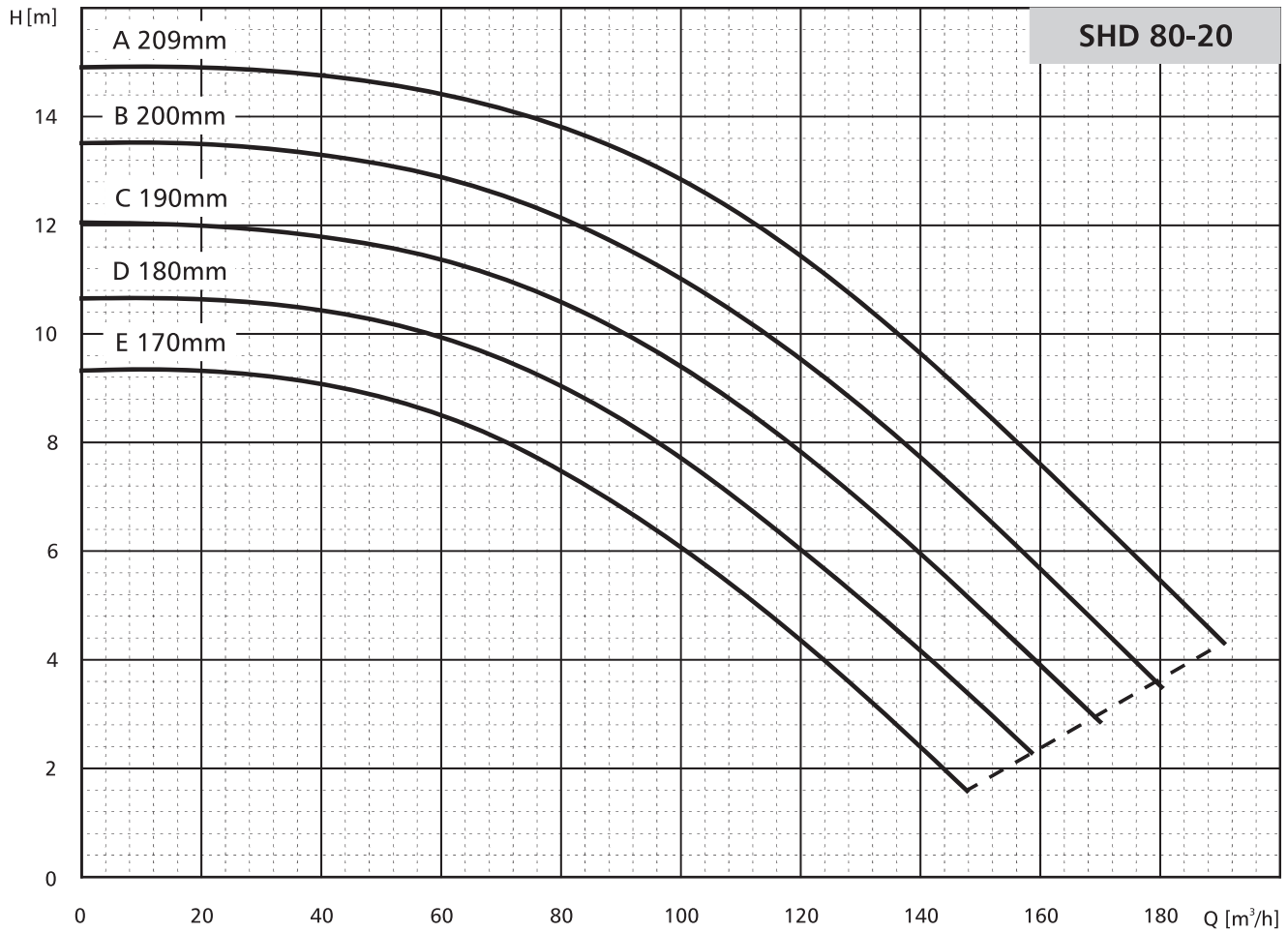

$n=2900\text{min}^{-1}$

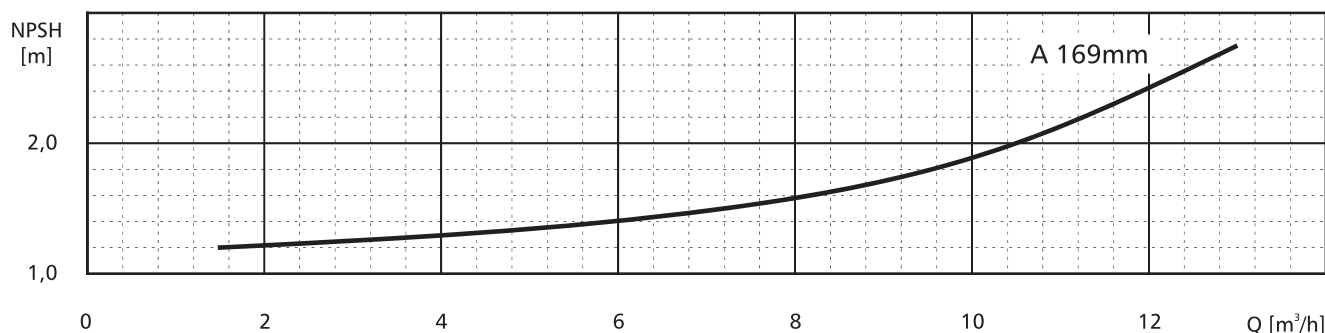
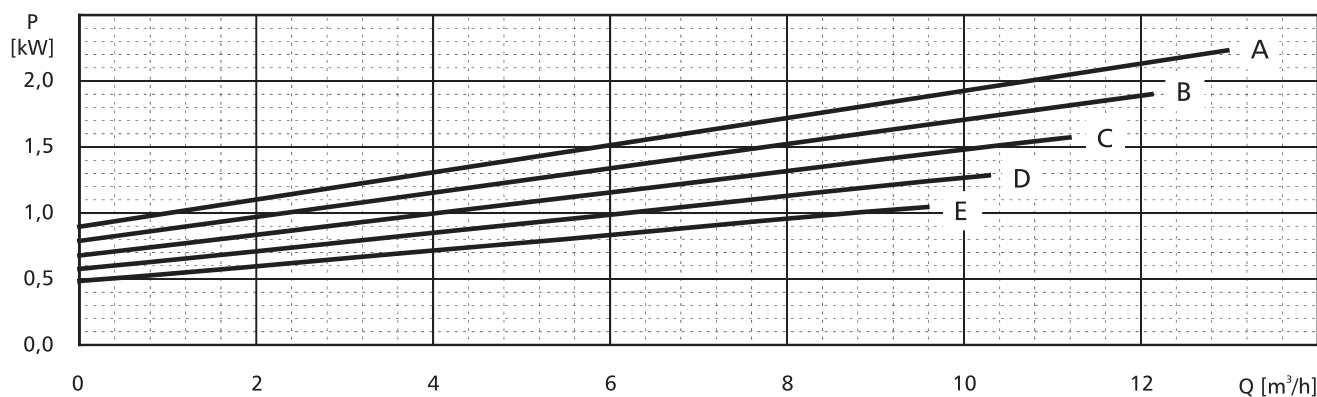
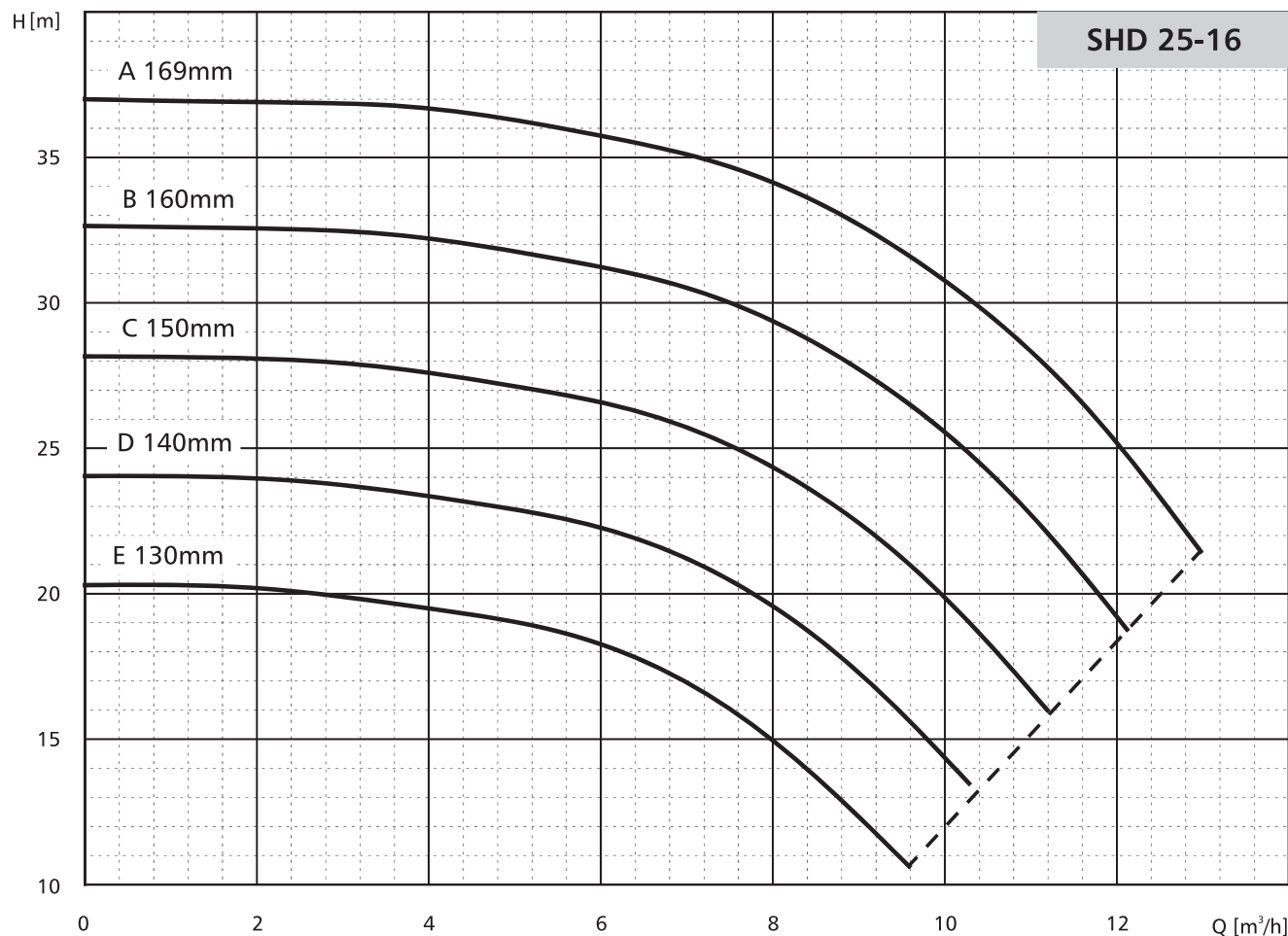

$n=2900\text{min}^{-1}$

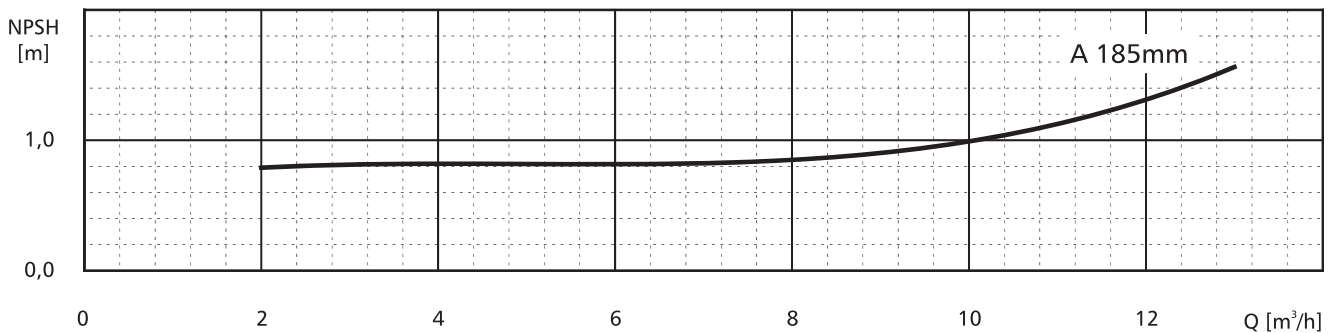
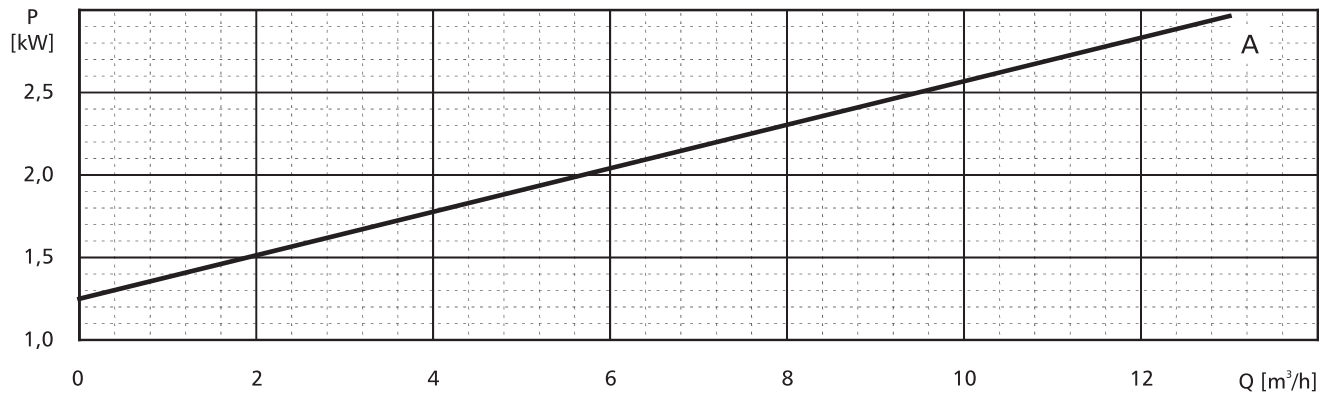
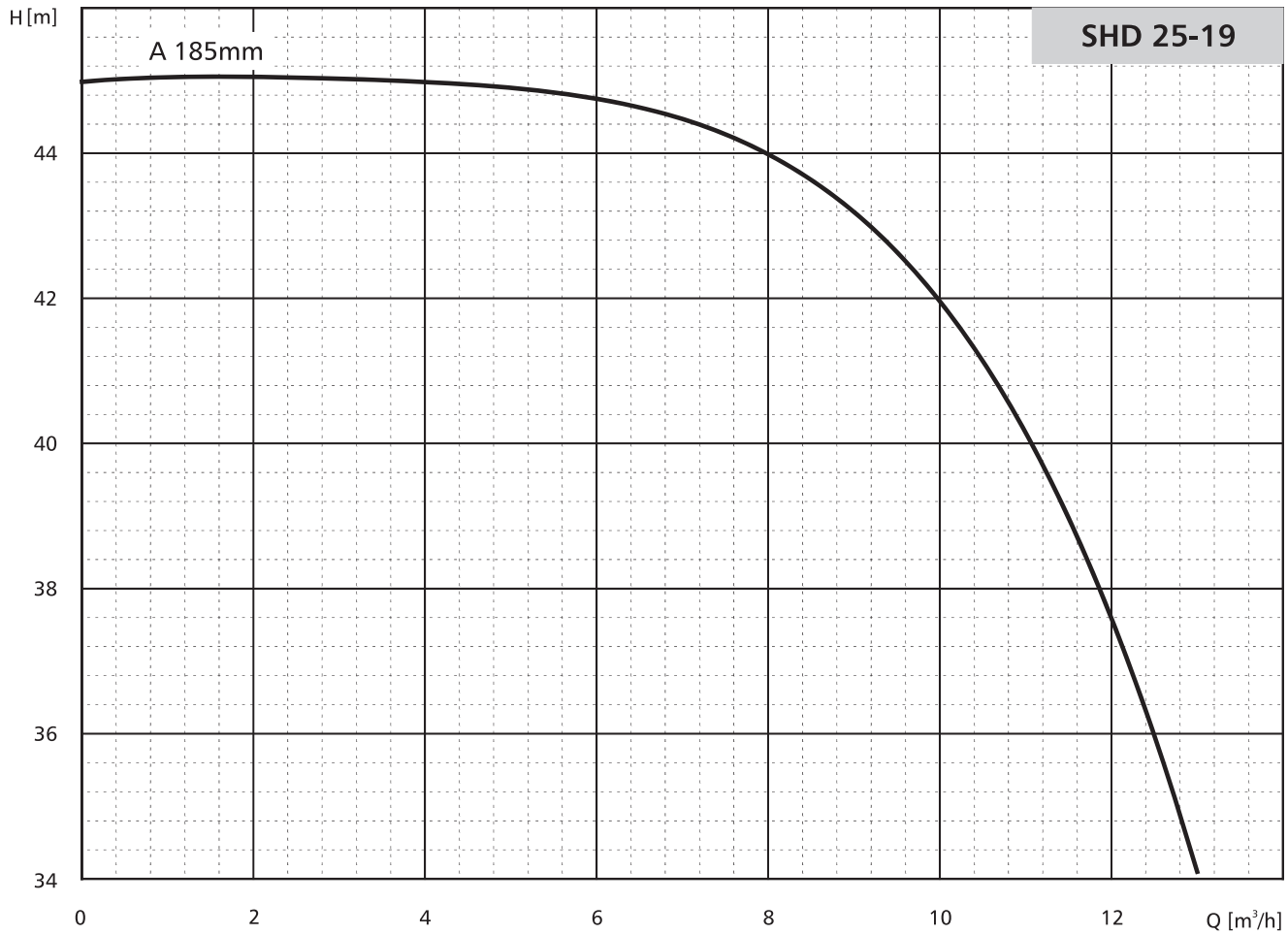

$n=2900\text{min}^{-1}$

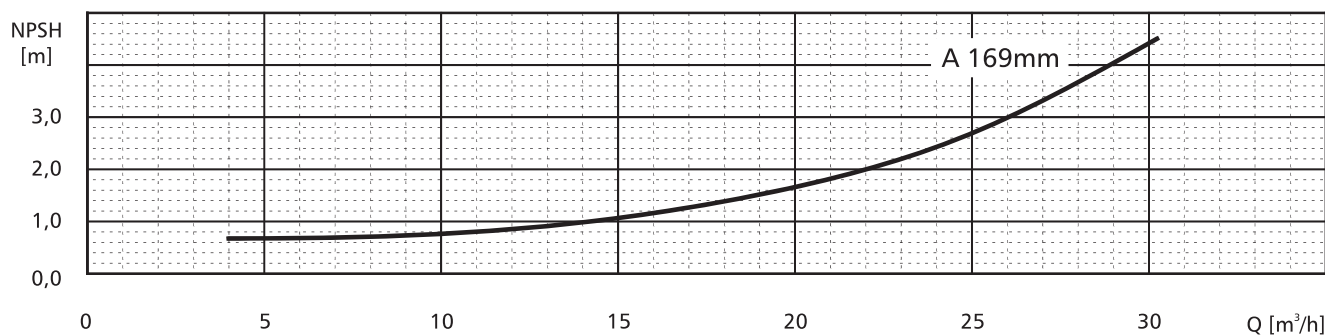
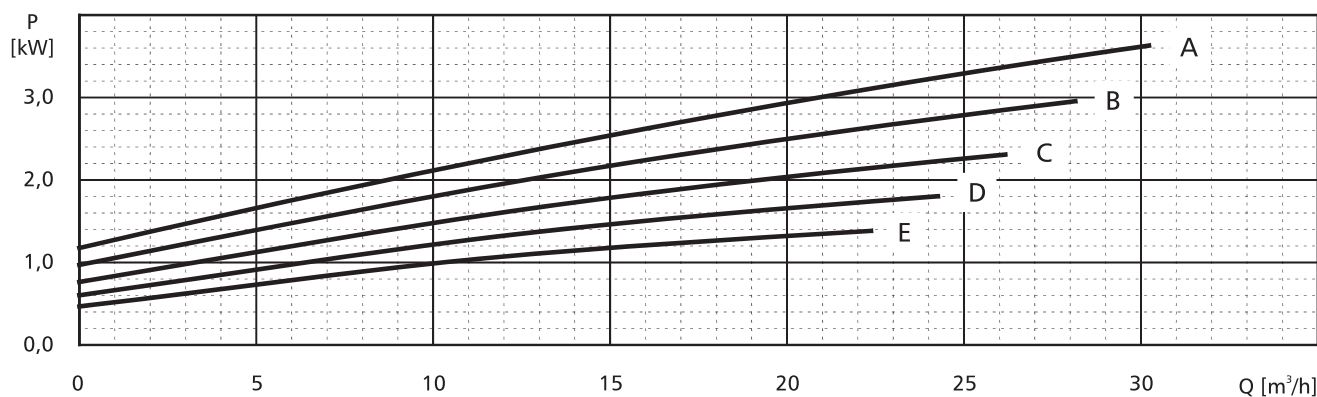
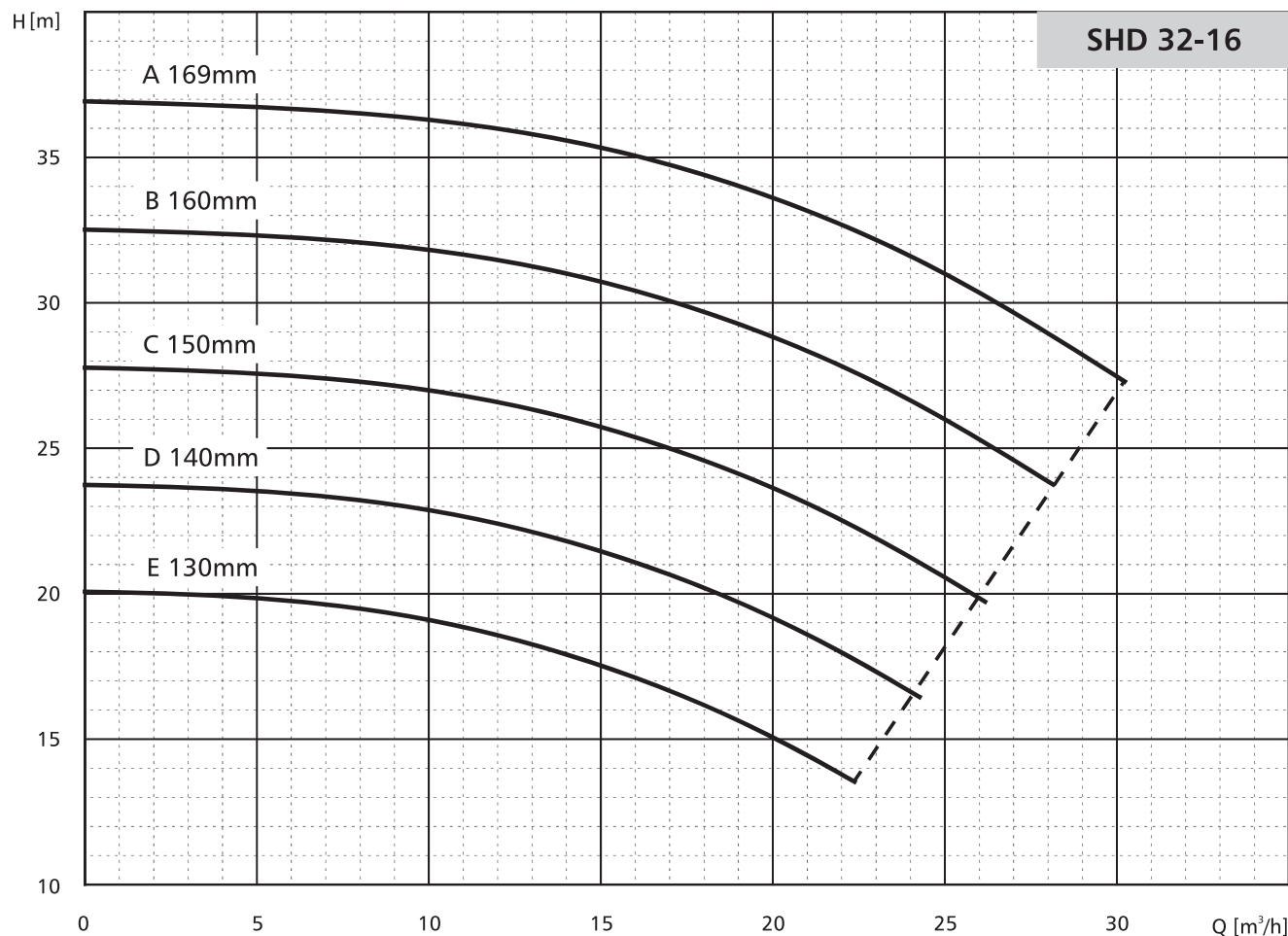

$n=2900\text{min}^{-1}$

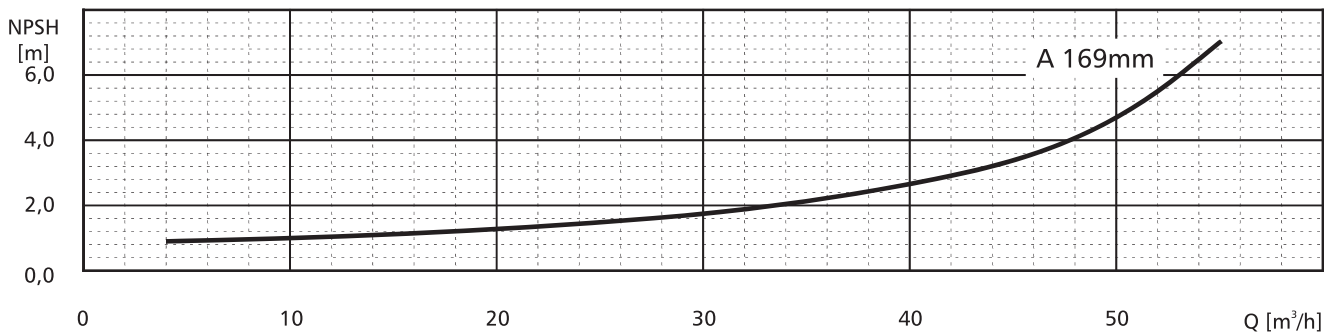
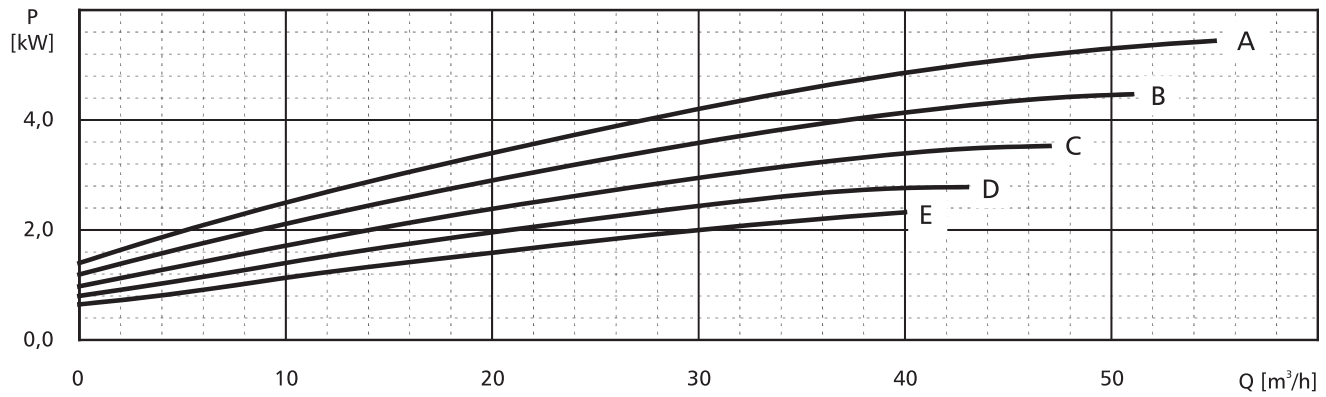
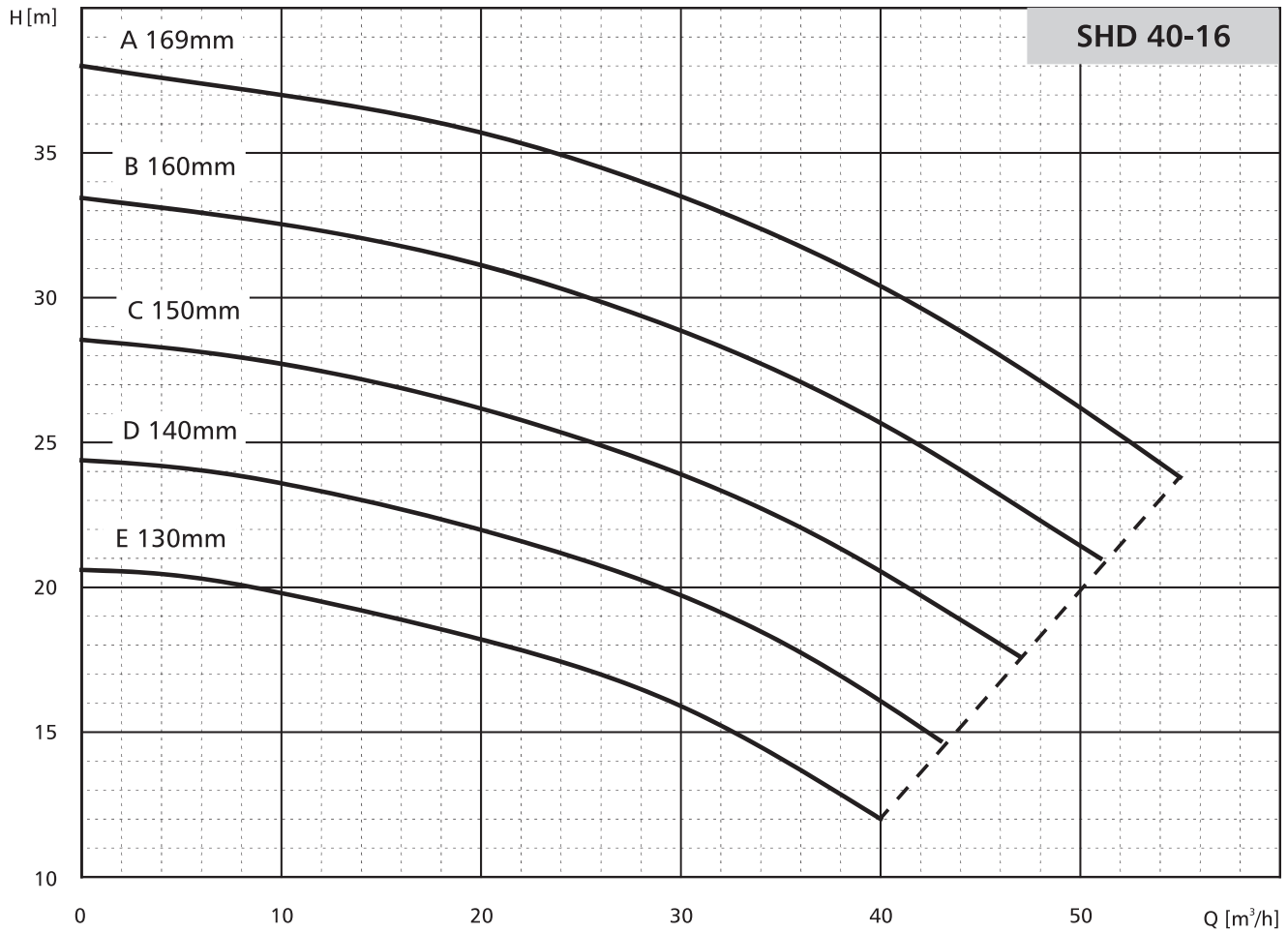

$n=2900\text{min}^{-1}$

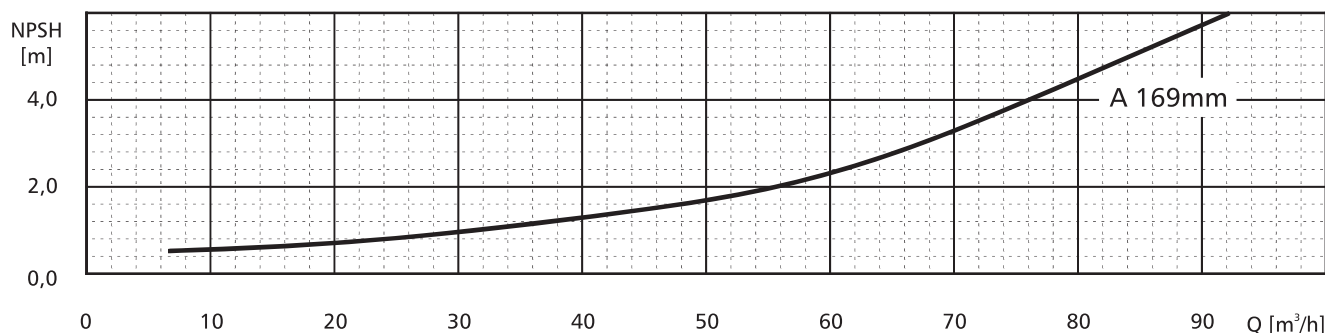
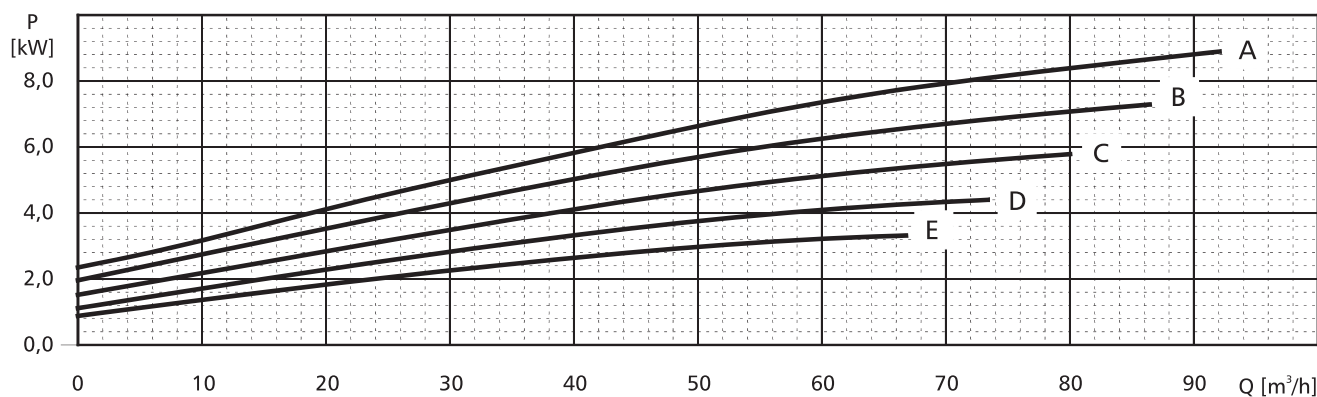
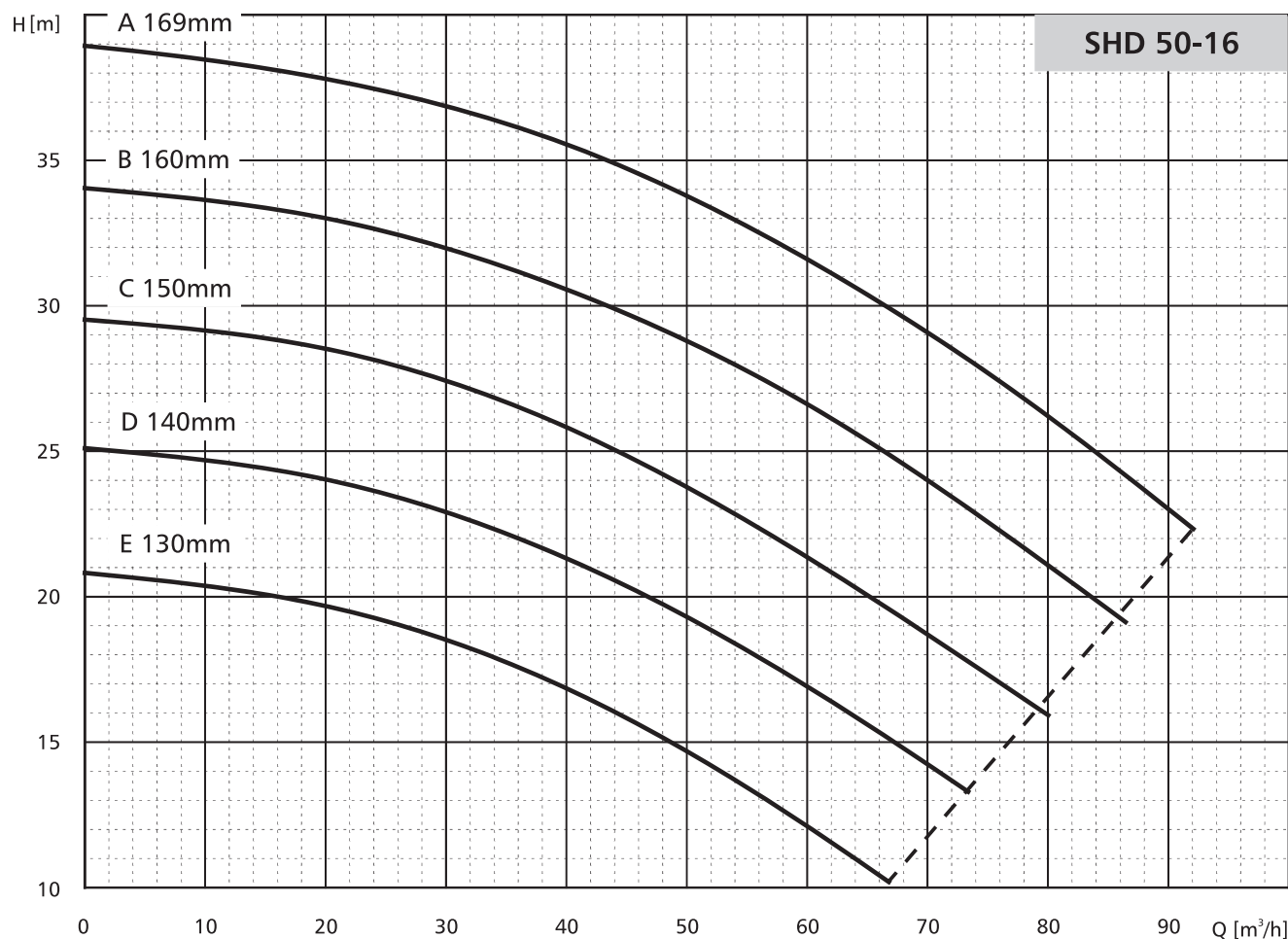

POMPY SPECJALISTYCZNE

$n=2900\text{min}^{-1}$

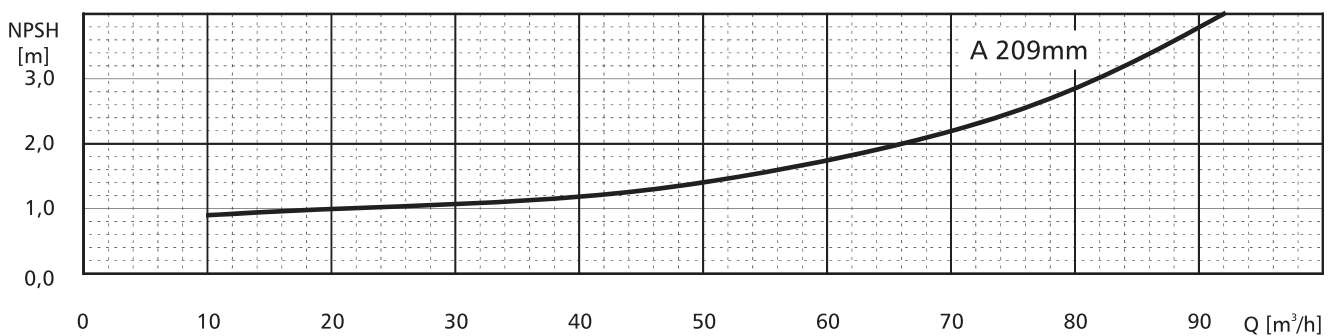
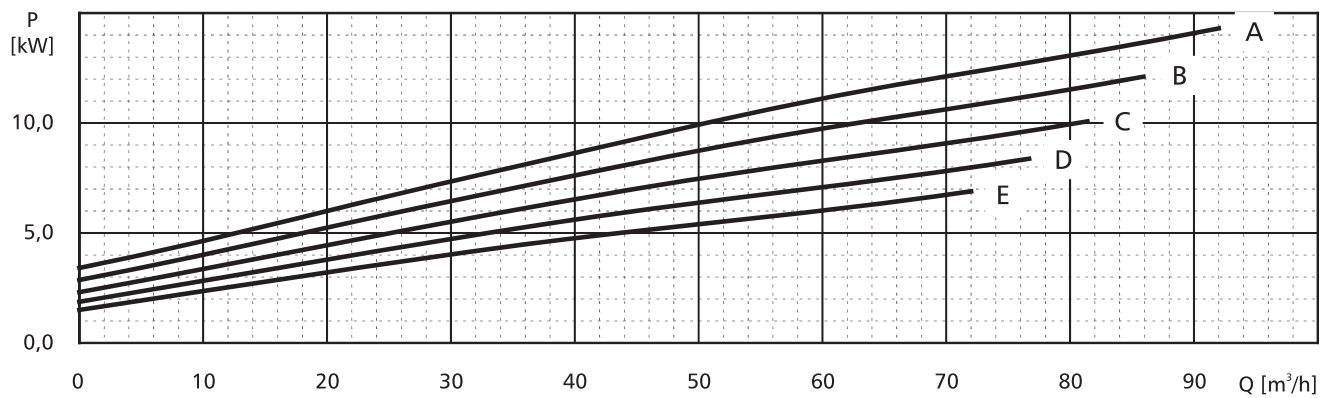
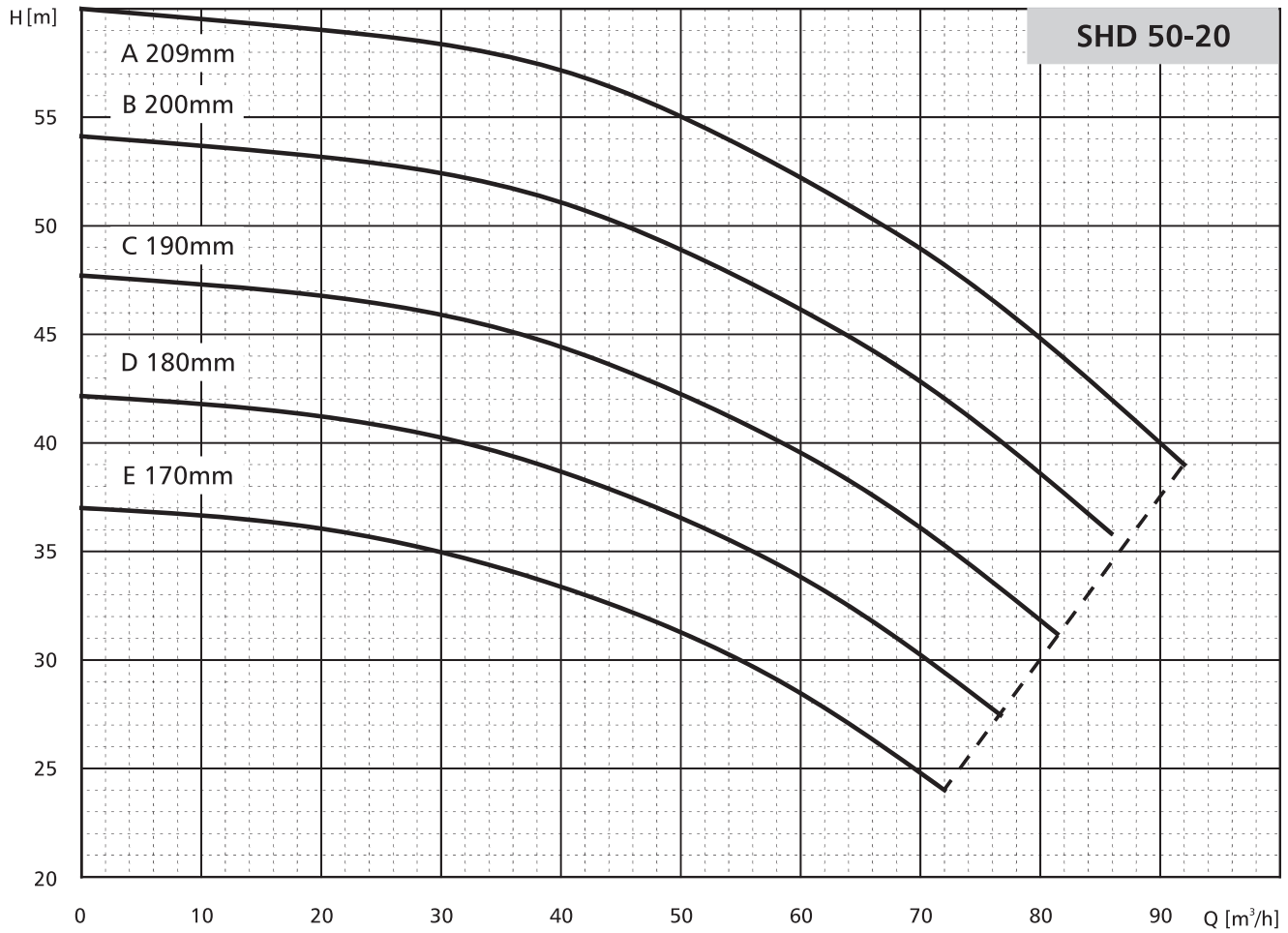

$n=2900\text{min}^{-1}$

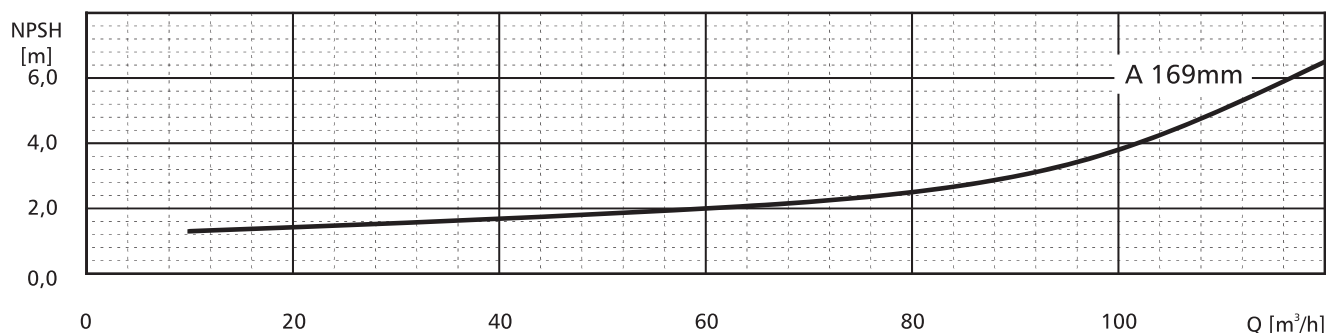
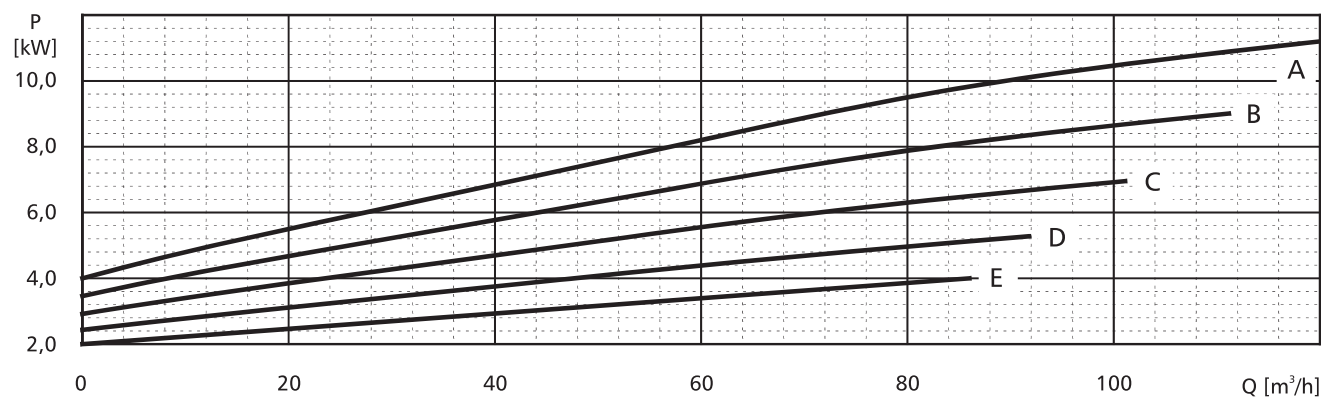
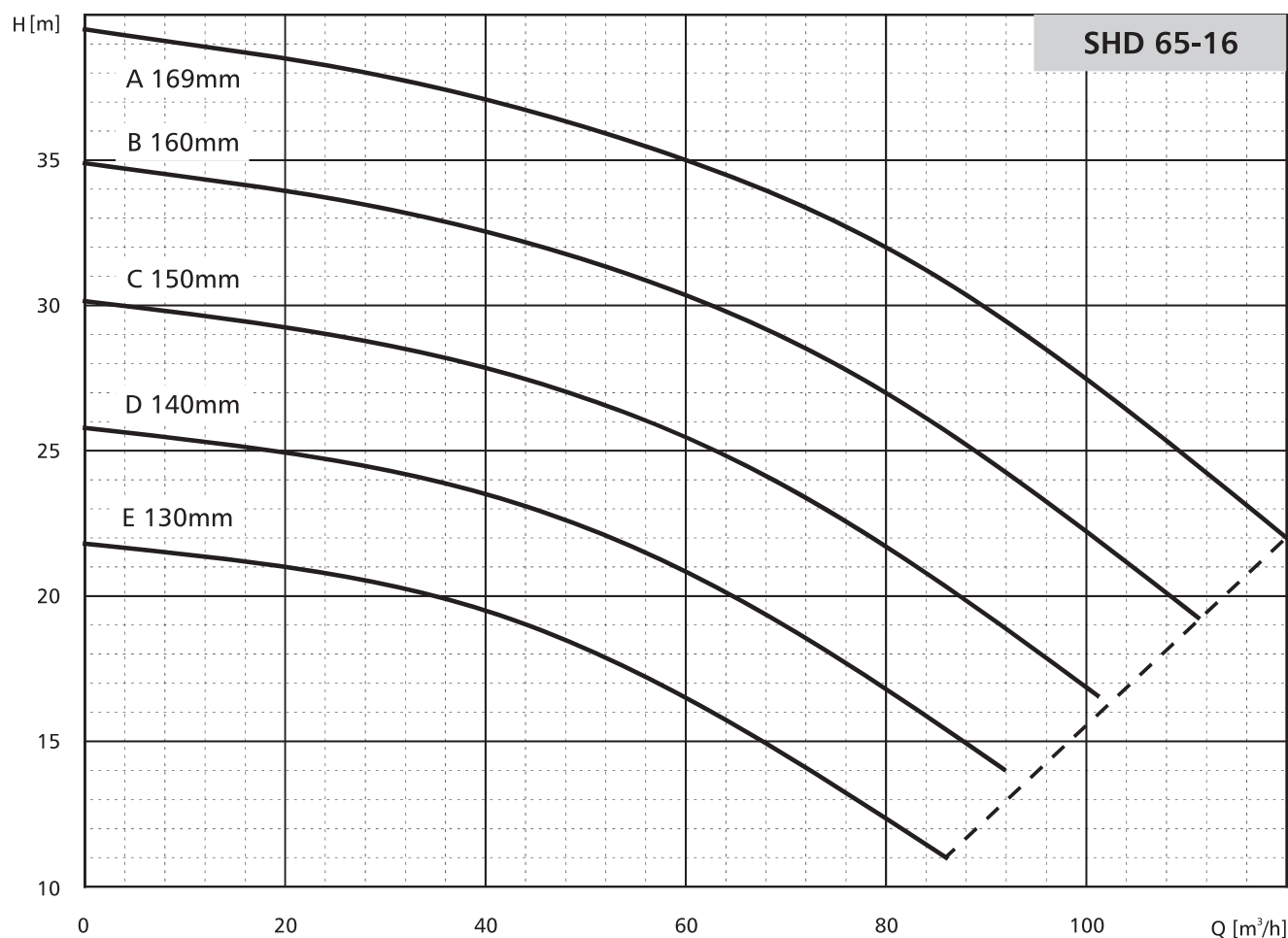

$n=2900\text{min}^{-1}$

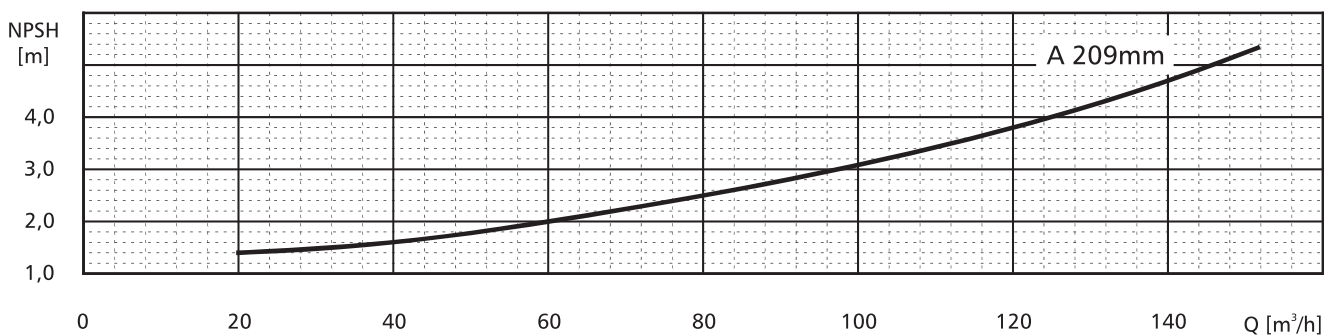
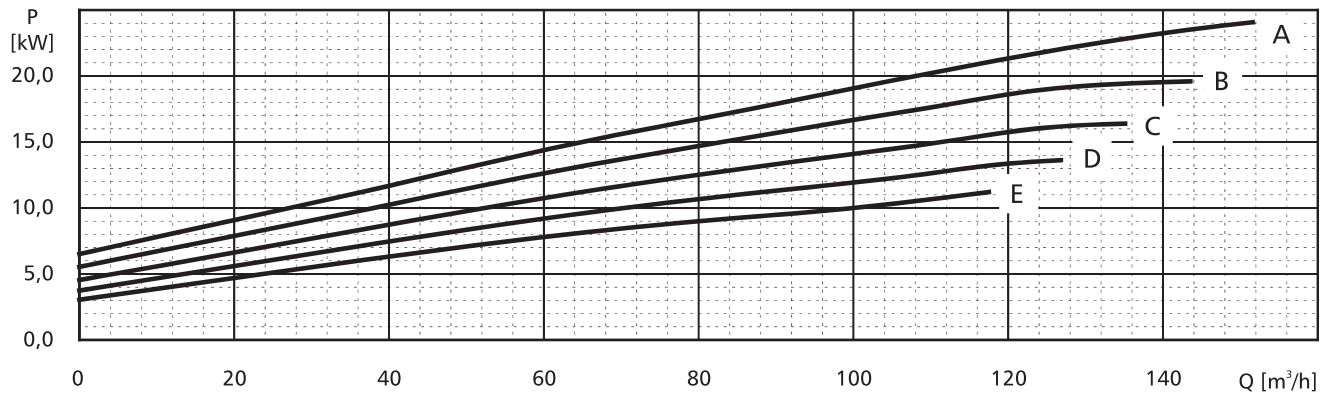
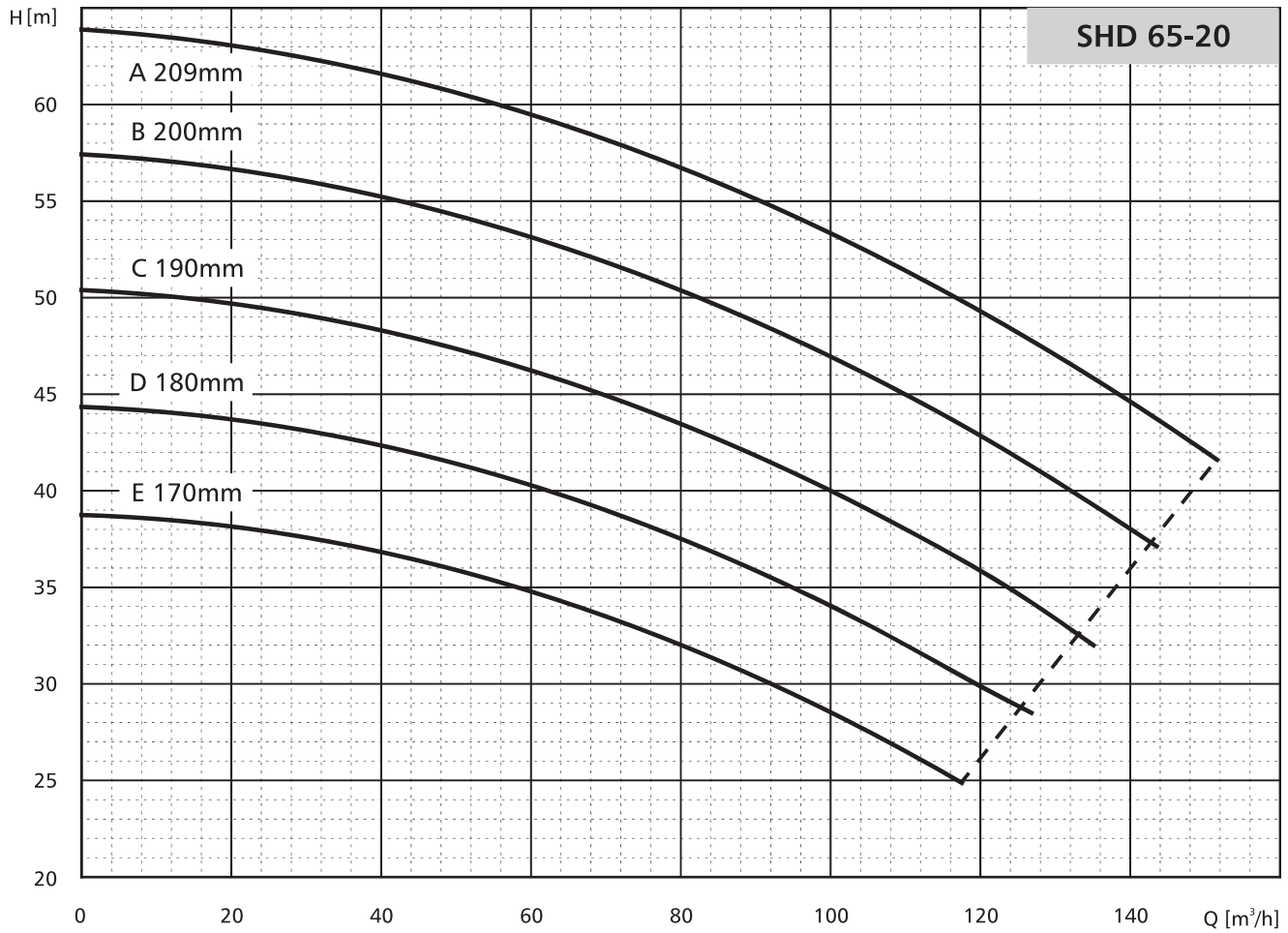

$n=2900\text{min}^{-1}$

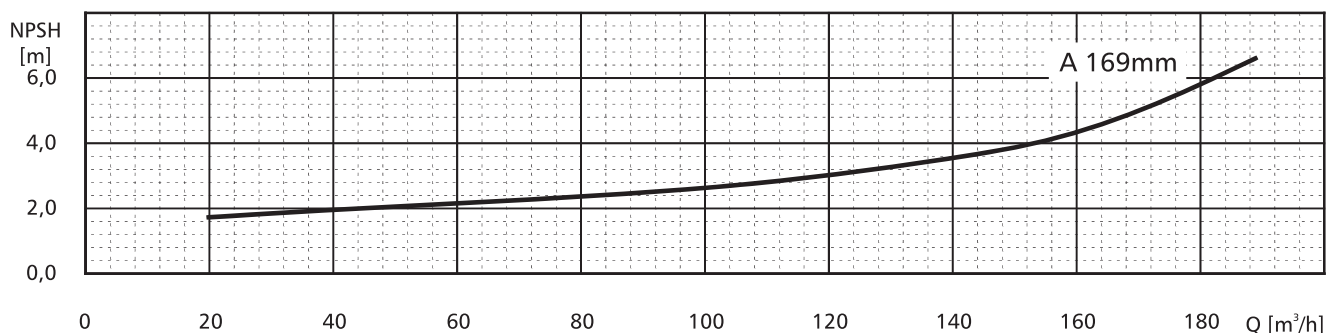
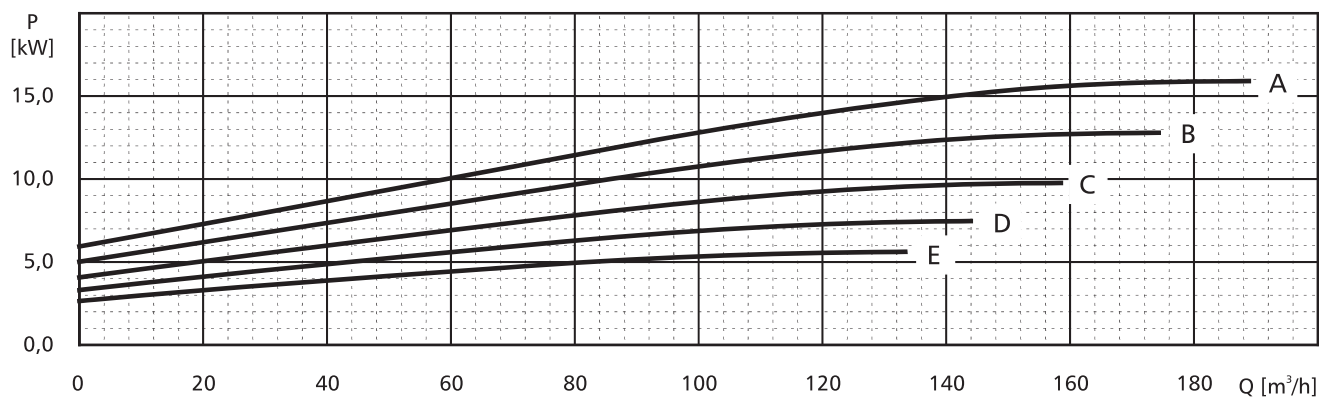
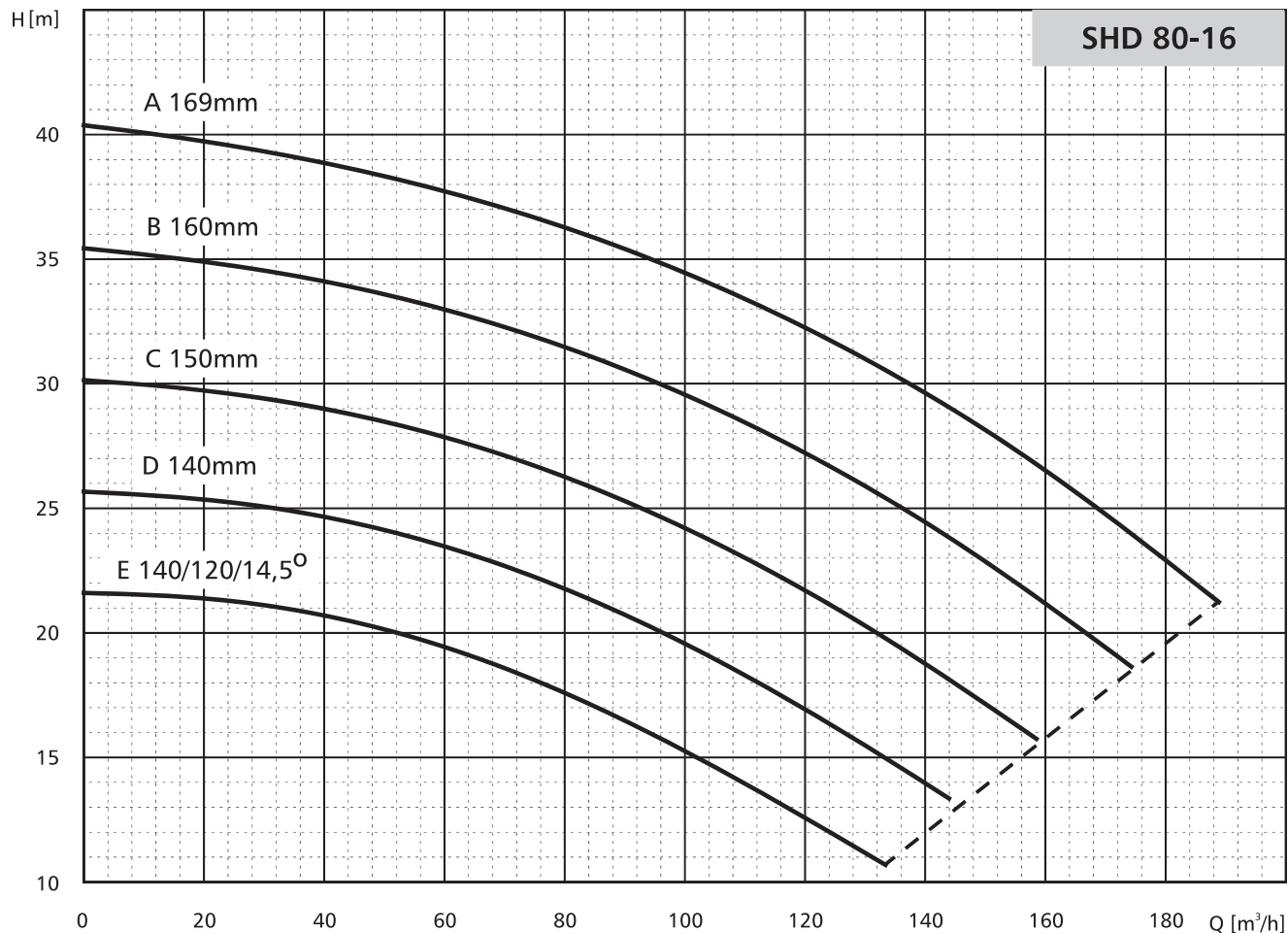

$n=2900\text{min}^{-1}$

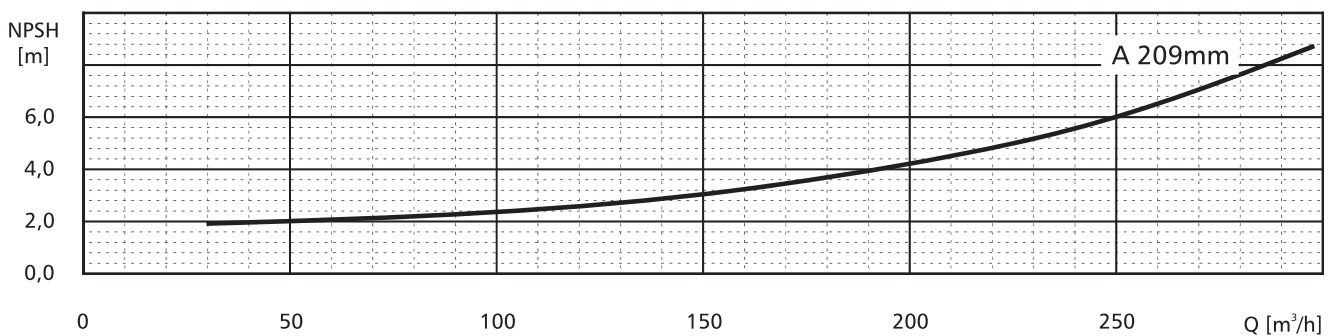
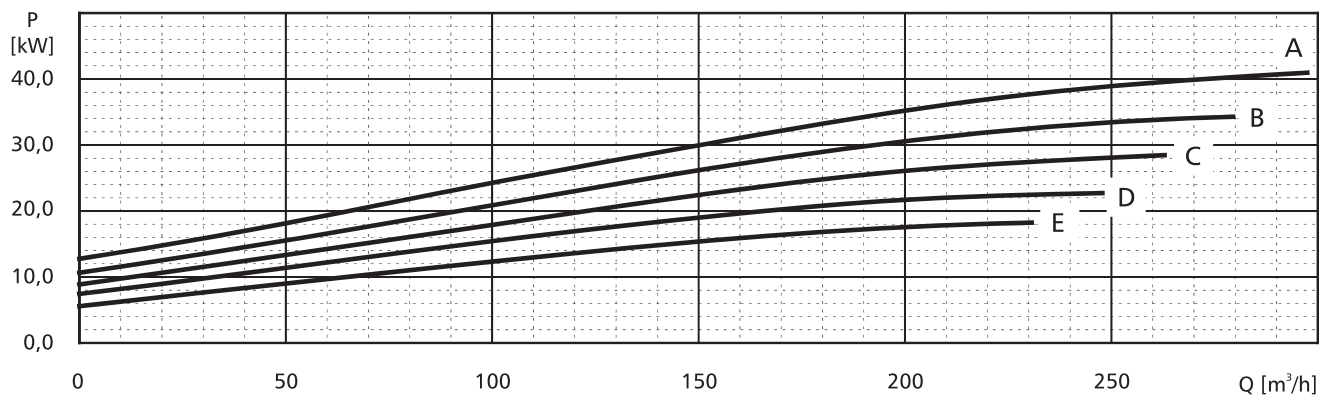
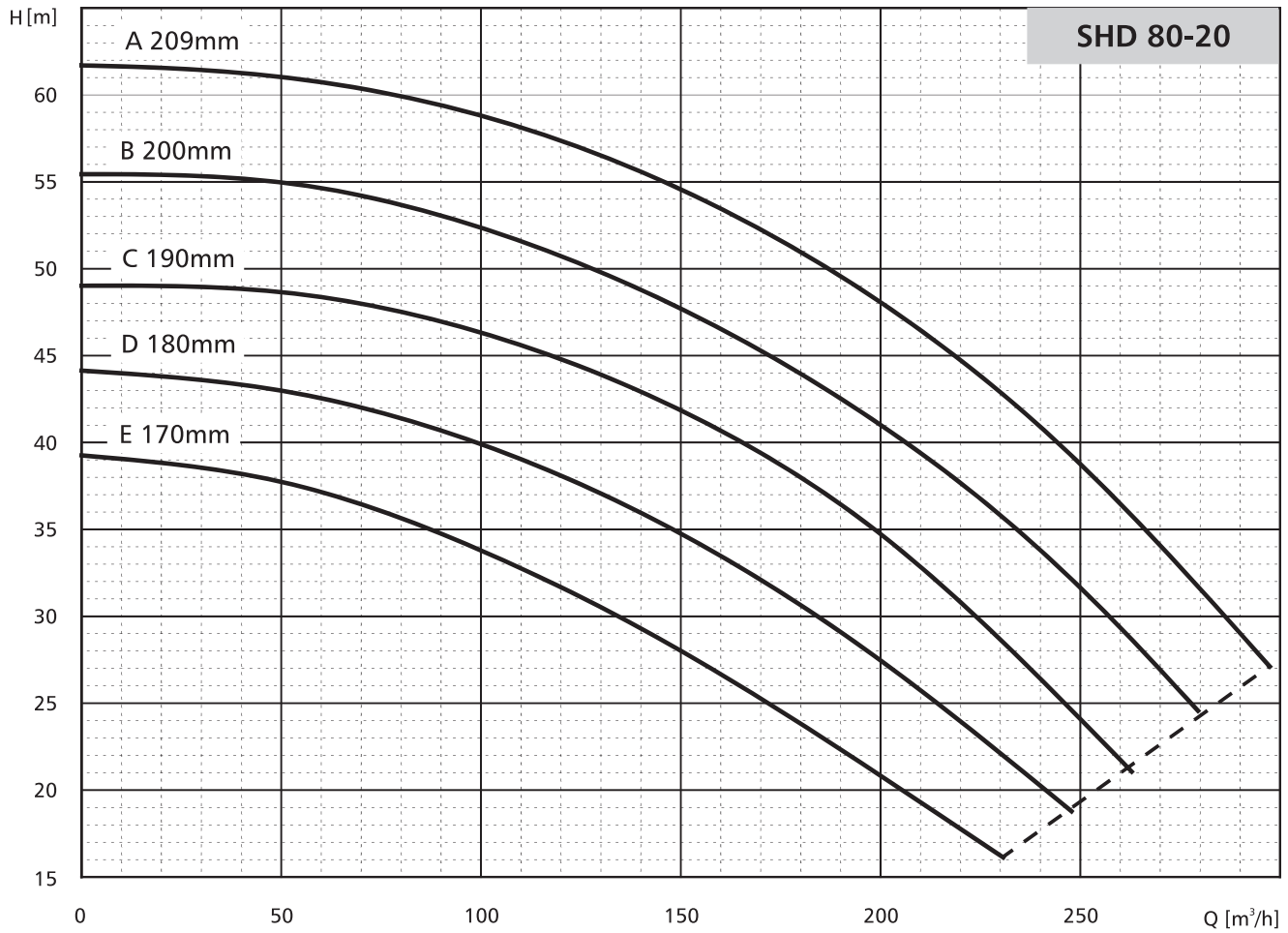

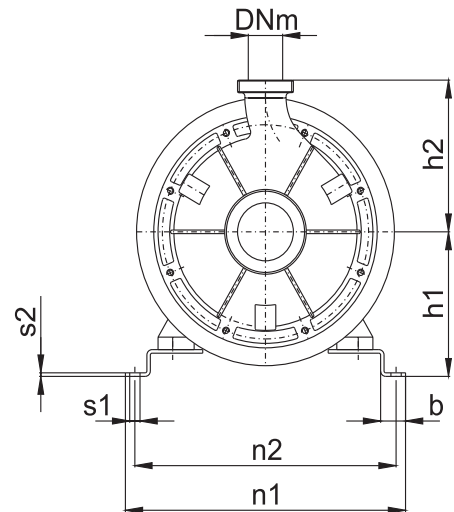
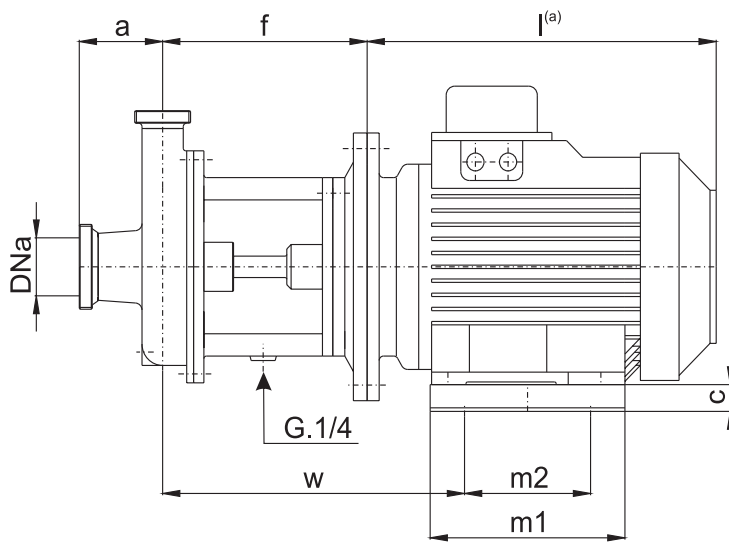

Wielkość mechaniczna silnika	Moc [kW]			L* [mm]	Masa [kg]
	n=2900min ⁻¹	n=1400min ⁻¹	n=950min ⁻¹		
80	0.75	0.55	0.37	232	9
80	1.1	0.75	0.55	232	10
90	1.5	1.1	0.75	270	13
90	2.2	1.5	1.1	270	16
100	3	2.2	1.5	298	21
100	-	3	-	298	23
112	4	4	2.2	312	30
132	5.5	5.5	3	381	40
132	7.5	7.5	4	381	50
132	9.2	9.2	5.5	381	50
160	11	11	7.5	486	76
160	15	15	11	486	85
160	18.5	-	-	486	95
180	22	18.5	15	576	130
180	-	22	-	576	145

* wymiary i masa silnika zależne od dostawy silnika

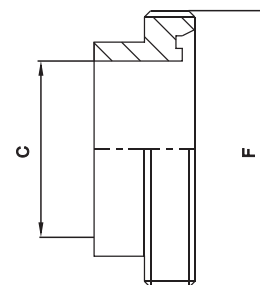

DIN 11851		
DN	C	F
25	25,0	52x1/6
32	31,0	58x1/6
40	37,0	65x1/6
50	49,0	78x1/6
65	66,0	95x1/6
80	81,0	110x1/4
100	97,6	130x1/4

POMPY SPECJALISTYCZNE

Typ pompy SHD A	Wielkość mechaniczna silnika	Wymiary [mm]														Masa [kg]	
		DNa	DNm	a	f	h1	h2	b	c	m1	m2	n1	n2	s1	s2		w
25-16	80	40	25	76	194	155	161	23	75	300	220	203	183	10	3	184	15
	90	"	"	"	194	165	"	23	75	300	220	216	198	10	3	190	15
	100	"	"	"	214	155	"	25	55	280	200	240	218	12	3	247	21
	112	"	"	"	214	167	"	25	55	280	200	270	248	12	3	254	21
32-16	80	50	32	95	194	155	175	23	75	300	220	203	183	10	3	184	18
	90	"	"	"	194	165	"	23	75	300	220	218	198	10	3	190	18
	100	"	"	"	214	155	"	25	55	280	200	240	218	12	3	247	24
	112	"	"	"	214	167	"	25	55	280	200	270	248	12	3	254	24
	132	"	"	"	234	162	"	29	30	340	220	326	304	14	4	283	24
32-20	80	50	32	95	212	155	195	23	75	300	220	203	183	10	3	202	25
	90	"	"	"	212	165	"	23	75	300	220	218	198	10	3	208	25
	100	"	"	"	232	155	"	25	55	280	200	240	218	12	3	265	31
	112	"	"	"	232	167	"	25	55	280	200	270	248	12	3	272	31
	132	"	"	"	252	162	"	29	30	340	220	326	304	14	4	301	31
40-16	80	65	40	97	198	155	175	23	75	300	220	203	183	10	3	188	20
	90	"	"	"	198	165	"	23	75	300	220	218	198	10	3	194	20
	100	"	"	"	218	155	"	25	55	280	200	240	218	12	3	251	26
	112	"	"	"	218	167	"	25	55	280	200	270	248	12	3	258	26
	132	"	"	"	238	162	"	29	30	340	220	326	304	14	4	287	26
40-20	80	65	40	117	216	155	195	23	75	300	220	203	183	10	3	206	26
	90	"	"	"	216	165	"	23	75	300	220	218	198	10	3	212	26
	100	"	"	"	236	155	"	25	55	280	200	240	218	12	3	269	32
	112	"	"	"	236	167	"	25	55	280	200	270	248	12	3	276	32
	132	"	"	"	256	162	"	29	30	340	220	326	304	14	4	305	32
	160	"	"	"	286	210	"	45	50	500	350	404	364	15	4	324	40
50-16	80	80	50	133	203	155	195	23	75	300	220	203	183	10	3	193	21
	90	"	"	"	203	165	"	23	75	300	220	218	198	10	3	199	21
	100	"	"	"	223	155	"	25	55	280	200	240	218	12	3	256	27
	112	"	"	"	223	167	"	25	55	280	200	270	248	12	3	263	27
	132	"	"	"	243	162	"	29	30	340	220	326	304	14	4	292	27
	160	"	"	"	273	210	"	45	50	500	350	404	364	15	5	311	32
50-20	80	80	50	133	221	155	215	23	75	300	220	203	183	10	3	211	27
	90	"	"	"	221	165	"	23	75	300	220	218	198	10	3	217	27
	100	"	"	"	238	155	"	25	55	280	200	240	218	12	3	271	33
	112	"	"	"	238	167	"	25	55	280	200	270	248	12	3	281	33
	132	"	"	"	261	162	"	29	30	340	220	326	304	14	4	310	33
	160	"	"	"	291	210	"	45	50	500	350	404	364	15	5	329	41
65-16	80	100	65	143	230	155	217	23	75	300	220	203	183	10	3	220	29
	90	"	"	"	230	165	"	23	75	300	220	218	198	10	3	225	29
	100	"	"	"	250	155	"	25	55	280	200	240	218	12	3	282	35
	112	"	"	"	250	167	"	25	55	280	200	270	248	12	3	290	35
	132	"	"	"	270	162	"	29	30	340	220	326	304	14	4	318	35
	160	"	"	"	300	210	"	45	50	500	350	404	364	15	5	338	43
65-20	90	100	65	143	229	190	242	30	100	370	220	234	207	12	3	225	35
	100	"	"	"	249	200	"	30	100	370	220	254	227	12	3	272	41
	112	"	"	"	249	212	"	30	100	370	220	284	257	12	3	279	41
	132	"	"	"	269	212	"	31	80	400	300	325	298	12	4	278	41
	160	"	"	"	299	210	"	45	50	500	350	404	364	15	5	337	49
	180	"	"	"	299	230	"	45	50	500	350	429	389	15	5	365	49
80-16	90	125	80	170	236	190	258	30	100	370	220	234	207	12	3	232	37
	100	"	"	"	256	200	"	30	100	370	220	254	227	12	3	279	43
	112	"	"	"	256	212	"	30	100	370	220	284	257	12	3	286	43
	132	"	"	"	276	212	"	31	80	400	300	325	298	12	4	285	43
	160	"	"	"	306	210	"	45	50	500	350	404	364	15	5	344	51
	180	"	"	"	306	230	"	45	50	500	350	429	389	15	5	372	51
80-20	90	125	80	170	236	190	283	30	100	370	220	234	207	12	3	232	40
	100	"	"	"	256	200	"	30	100	370	220	254	227	12	3	279	46
	112	"	"	"	256	212	"	30	100	370	220	284	257	12	3	286	46
	132	"	"	"	276	212	"	31	80	400	300	325	298	12	4	285	46
	160	"	"	"	306	210	"	45	50	500	350	404	364	15	5	344	54
	180	"	"	"	306	230	"	45	50	500	350	429	389	15	5	372	54

* Masa pomp bez silnika elektrycznego, masa silników podana w tabeli dane elektryczne

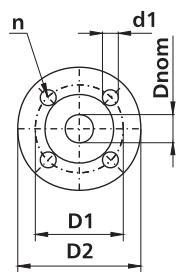
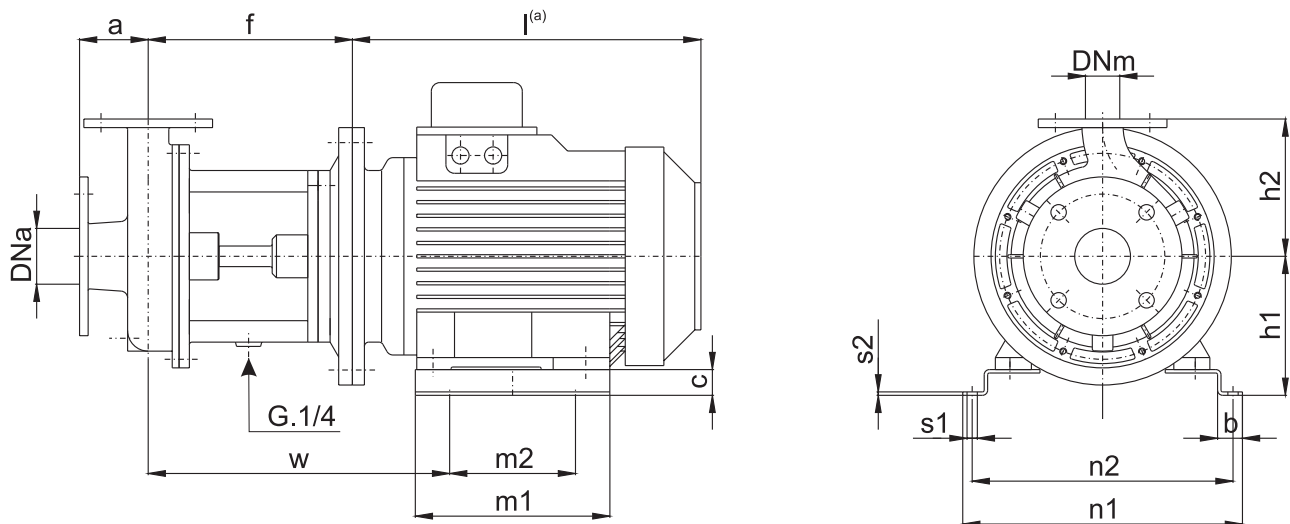

Wymiary przyłączy								
Dnom	25	32	40	50	65	80	100	125
D1	85	100	110	125	145	160	180	210
D2	115	140	150	165	185	200	220	250
d1	14	18	18	18	18	18	18	18
n	4	4	4	4	4	8	8	8

Wielkość mechaniczna silnika	Moc [kW]			L* [mm]	Masa [kg]
	n=2900min ⁻¹	n=1400min ⁻¹	n=950min ⁻¹		
80	0.75	0.55	0.37	232	9
80	1.1	0.75	0.55	232	10
90	1.5	1.1	0.75	270	13
90	2.2	1.5	1.1	270	16
100	3	2.2	1.5	298	21
100	-	3	-	298	23
112	4	4	2.2	312	30
132	5.5	5.5	3	381	40
132	7.5	7.5	4	381	50
132	9.2	9.2	5.5	381	50
160	11	11	7.5	486	76
160	15	15	11	486	85
160	18.5	-	-	486	95
180	22	18.5	15	576	130
180	-	22	-	576	145

* wymiary i masa silnika zależne od dostawcy silnika

POMPY SPECJALISTYCZNE

Typ pompy SHD	Wielkość mechaniczna silnika	Wymiary [mm]															Masa [kg]
		DNa	DNm	a	f	h1	h2	b	c	m1	m2	n1	n2	s1	s2	w	
25-16	80	40	25	60	187	155	147	23	75	300	220	203	183	10	3	177	15
	90	"	"	"	187	165	"	23	75	300	220	218	198	10	3	183	15
	100	"	"	"	207	155	"	25	55	280	200	240	218	12	3	240	21
	112	"	"	"	207	167	"	25	55	280	200	270	248	12	3	247	21
32-16	80	50	32	80	194	155	160	23	75	300	220	203	183	10	3	184	18
	90	"	"	"	194	165	"	23	75	300	220	218	198	10	3	190	18
	100	"	"	"	214	155	"	25	55	280	200	240	218	12	3	247	24
	112	"	"	"	214	167	"	25	55	280	200	270	248	12	3	254	24
	132	"	"	"	234	162	"	29	30	340	220	326	304	14	4	283	24
32-20	80	50	32	80	212	155	180	23	75	300	220	203	183	10	3	202	25
	90	"	"	"	212	165	"	23	75	300	220	218	198	10	3	208	25
	100	"	"	"	232	155	"	25	55	280	200	240	218	12	3	265	31
	112	"	"	"	232	167	"	25	55	280	200	270	248	12	3	272	31
	132	"	"	"	252	162	"	29	30	340	220	326	304	14	4	301	31
40-16	80	65	40	80	198	155	160	23	75	300	220	203	183	10	3	188	20
	90	"	"	"	198	165	"	23	75	300	220	218	198	10	3	194	20
	100	"	"	"	218	155	"	25	55	280	200	240	218	12	3	251	26
	112	"	"	"	218	167	"	25	55	280	200	270	248	12	3	258	26
	132	"	"	"	238	162	"	29	30	340	220	326	304	14	4	287	26
40-20	80	65	40	100	216	155	180	23	75	300	220	203	183	10	3	206	26
	90	"	"	"	216	165	"	23	75	300	220	218	198	10	3	212	26
	100	"	"	"	236	155	"	25	55	280	200	240	218	12	3	269	32
	112	"	"	"	236	167	"	25	55	280	200	270	248	12	3	276	32
	132	"	"	"	256	162	"	29	30	340	220	326	304	14	4	305	32
	160	"	"	"	286	210	"	45	50	500	350	404	364	15	4	324	40
50-16	80	80	50	100	203	155	180	23	75	300	220	203	183	10	3	193	21
	90	"	"	"	203	165	"	23	75	300	220	218	198	10	3	199	21
	100	"	"	"	223	155	"	25	55	280	200	240	218	12	3	256	27
	112	"	"	"	223	167	"	25	55	280	200	270	248	12	3	263	27
	132	"	"	"	243	162	"	29	30	340	220	326	304	14	4	292	27
	160	"	"	"	273	210	"	45	50	500	350	404	364	15	5	311	32
50-20	80	80	50	100	221	155	200	23	75	300	220	203	183	10	3	211	27
	90	"	"	"	221	165	"	23	75	300	220	218	198	10	3	217	27
	100	"	"	"	238	155	"	25	55	280	200	240	218	12	3	271	33
	112	"	"	"	238	167	"	25	55	280	200	270	248	12	3	281	33
	132	"	"	"	261	162	"	29	30	340	220	326	304	14	4	310	33
	160	"	"	"	291	210	"	45	50	500	350	404	364	15	5	329	41
65-16	80	100	65	100	230	155	200	23	75	300	220	203	183	10	3	220	29
	90	"	"	"	230	165	"	23	75	300	220	218	198	10	3	225	29
	100	"	"	"	250	155	"	25	55	280	200	240	218	12	3	282	35
	112	"	"	"	250	167	"	25	55	280	200	270	248	12	3	290	35
	132	"	"	"	270	162	"	29	30	340	220	326	304	14	4	318	35
	160	"	"	"	300	210	"	45	50	500	350	404	364	15	5	338	43
65-20	90	100	65	100	229	190	225	30	100	370	220	234	207	12	3	225	35
	100	"	"	"	249	200	"	30	100	370	220	254	227	12	3	272	41
	112	"	"	"	249	212	"	30	100	370	220	284	257	12	3	279	41
	132	"	"	"	269	212	"	31	80	400	300	325	298	12	4	278	41
	160	"	"	"	299	210	"	45	50	500	350	404	364	15	5	337	49
	180	"	"	"	299	230	"	45	50	500	350	429	389	15	5	365	49
80-16	90	125	80	125	236	190	225	30	100	370	220	234	207	12	3	232	37
	100	"	"	"	256	200	"	30	100	370	220	254	227	12	3	279	43
	112	"	"	"	256	212	"	30	100	370	220	284	257	12	3	286	43
	132	"	"	"	276	212	"	31	80	400	300	325	298	12	4	285	43
	160	"	"	"	306	210	"	45	50	500	350	404	364	15	5	344	51
	180	"	"	"	306	230	"	45	50	500	350	429	389	15	5	372	51
80-20	90	125	80	125	236	190	250	30	100	370	220	234	207	12	3	232	40
	100	"	"	"	256	200	"	30	100	370	220	254	227	12	3	279	46
	112	"	"	"	256	212	"	30	100	370	220	284	257	12	3	286	46
	132	"	"	"	276	212	"	31	80	400	300	325	298	12	4	285	46
	160	"	"	"	306	210	"	45	50	500	350	404	364	15	5	344	54
	180	"	"	"	306	230	"	45	50	500	350	429	389	15	5	372	54

* Masa pomp bez silnika elektrycznego, masa silników podana w tabeli dane elektryczne