

VOGEL - Sewage Pumps
Channel Type Pumps, Design KS
Vortex Type Pumps, Design W, WTS

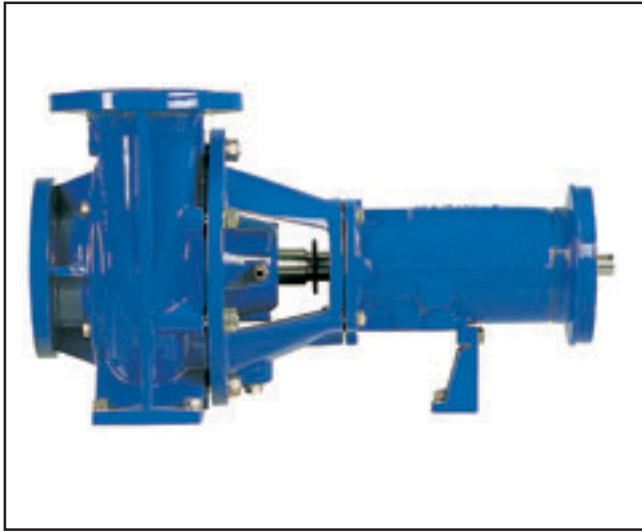

VOGEL - Pumps with Channel Type Impeller, Design KS



Performance Range:

Capacity up to 500 m³/h (2200 USgpm)
 Head up to 45 m (150 feet)
 Speed up to 1450 min⁻¹ (1450 r.p.m.)

Sizes:

DN 65 up to DN 150 (21/2" up to 6")
 discharge

Temperature:

max. 120°C (250° F)

Casing pressure:

up to 10 bar (145 psig)

Liquids:

Contaminated liquids with solids
 Waste water, sludge up to 8% atro
 Suspensions, effluents, etc.
 Raw, thick or thin juices

Applications:

Industrial or public waste and sewage plants
 Chemical industry
 Mining
 Sugar mills
 Pulp and paper mills

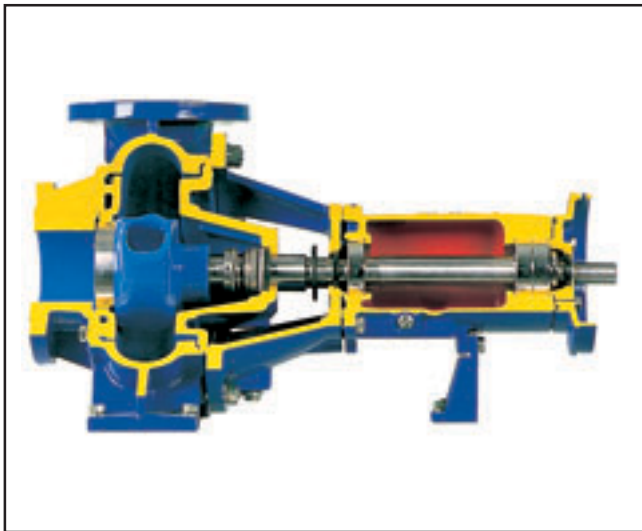

Mat. code	Impeller	Wear Plates	Casing, Casing cover	Wear rings 1)	Bearing frame, Lantern	Shaft	Shaft sleeve
N	Cast iron 0.6025	Cast iron 0.6025	Cast iron 0.6025	Cast iron 0.6025	Cast iron 0.6025	Stainl. steel 1.4021	Stainl. steel 1.4021
SN	Bronze 2.1050.01		Ductile iron 0.7040				
NL	Cast iron 0.6025						
VN	Stainl. steel 1.4408	Stainl. steel 1.4408	Cast iron 0.6025	Stainl. steel 1.4462			
VV			Stainl. steel 1.4408				Stainl. steel 1.4408

1) Casing wear ring optional
 Other materials and special version upon request

VOGEL - Pumps with Channel Type Impeller, Design KS

Performance Range:

1450 r.p.m.

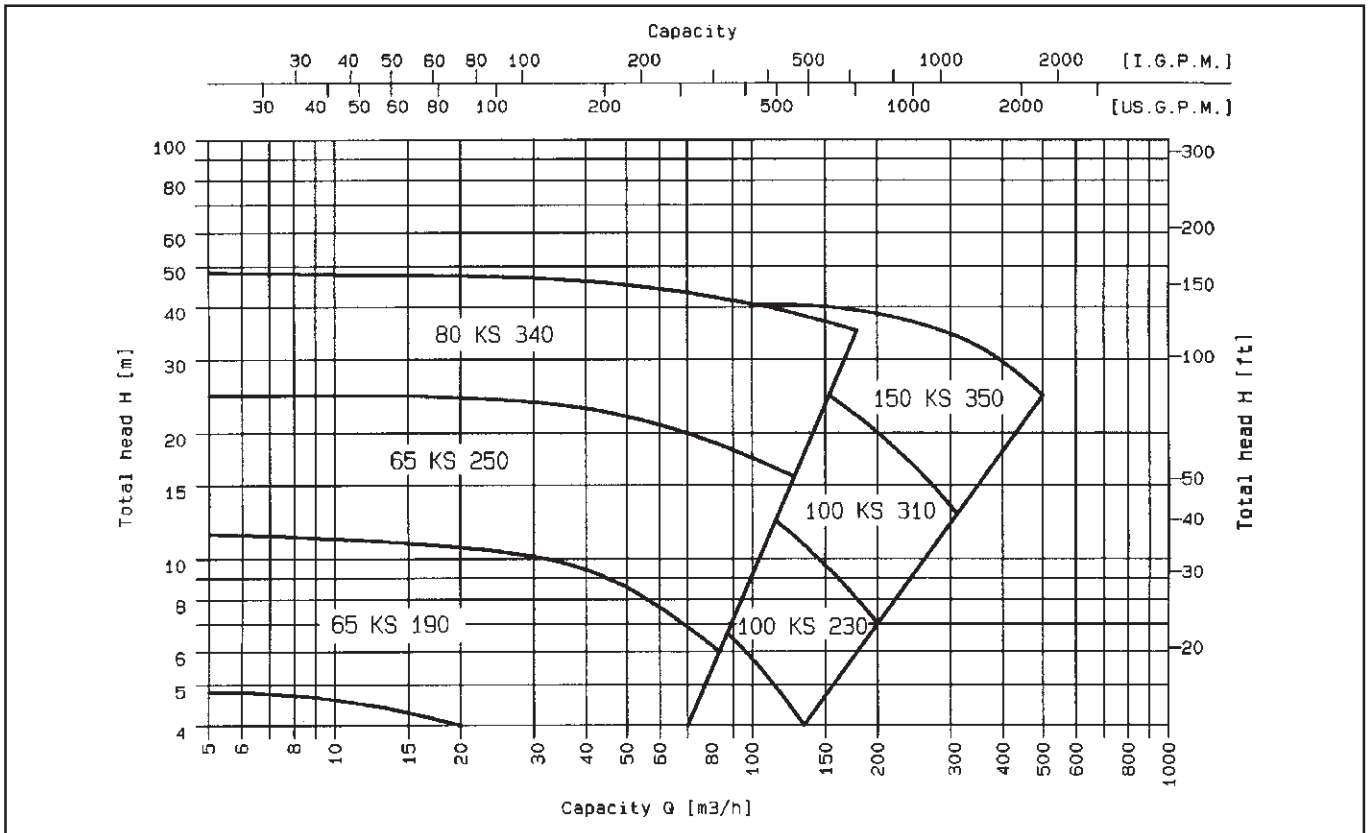

Performance Range:

950 r.p.m

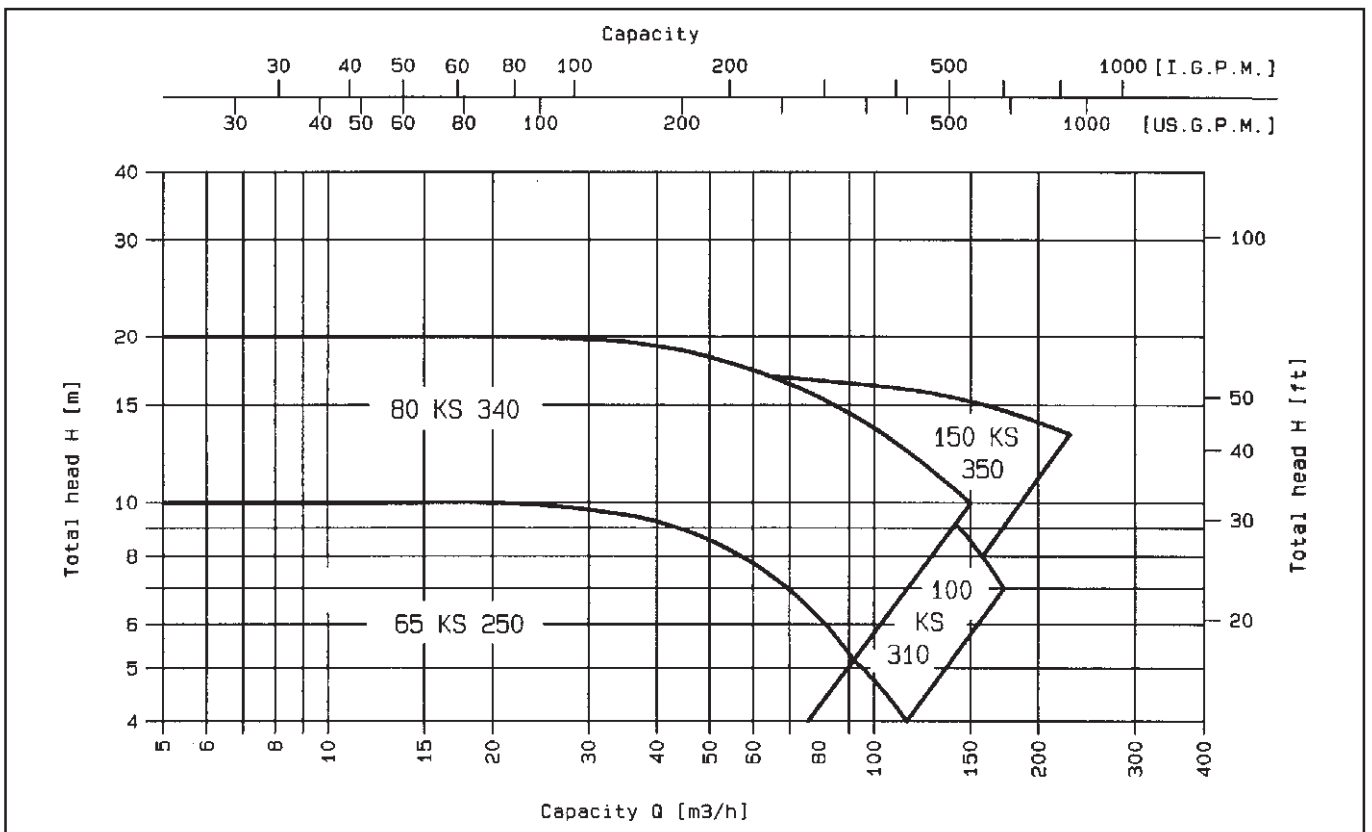

VOGEL - Pumps with Channel Type Impeller, Design KS

Design versions:

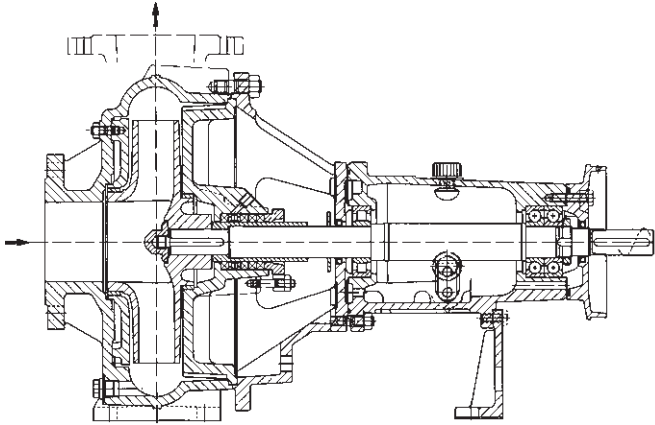

Design KS

Design KS:

Horizontal pump with closed two channel impeller with wear plate oil lubricated bearing frame. Easy maintenance by back pull out system, disassembling of impeller and bearing frame without disturbing the suction and discharge pipes and the driving motor (spacer type coupling required). Suction branch axial, discharge branch tangential upwards.

Electric drive through flexible coupling, pump and motor mounted on common base plate. Optional V-belt drive, reverse overhead mounted (huckepack design).

Design KSV:

Vertical short shaft version for dry pit installation. Bearing frame grease lubricated powered by vertical flanged IEC motors resting on motor lanterns either through flexible coupling or extended cardan shaft.

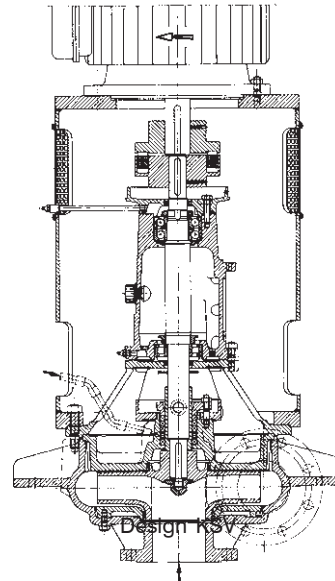

Design KSV

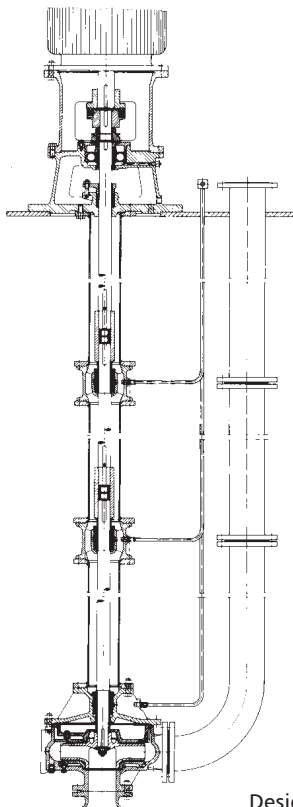

Design KST

Design KST:

Vertical line shaft version for wet or dry installation. Drive head with motor lantern arranged above pump sump or pump floor.

Radial bearings, sleeve bearing arranged in the column pipe. Lubricated by clear water.

Installation length up to 10 m.

VOGEL - Pumps with Channel Type Impeller, Design KS

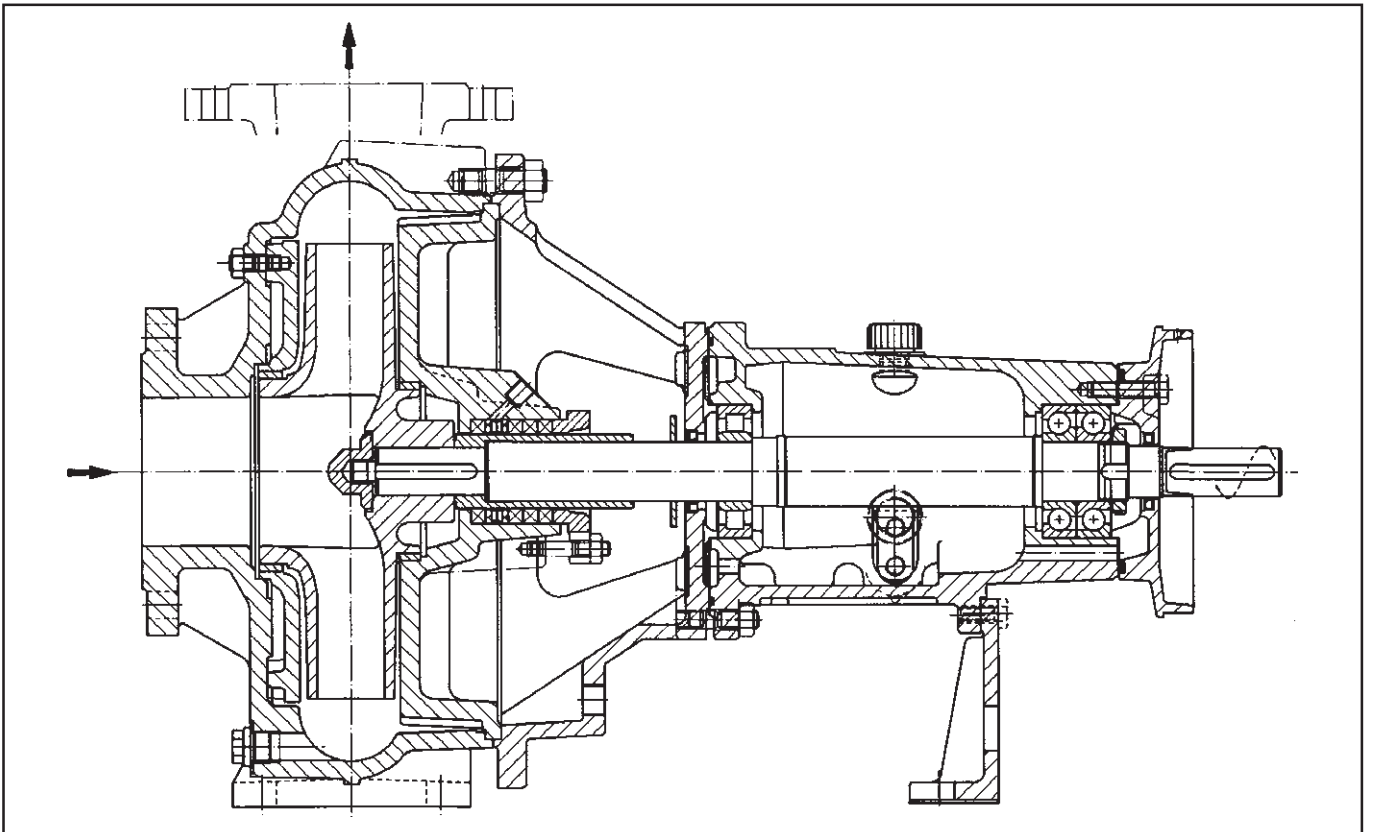

- Horizontal pump with closed two channel type impeller.
- Wear plate at suction side to protect the casing.
- Casing wear ring optionally available.
- Easy maintenance by back pull out design, disassembling of impeller, shaft sealing and bearing frame without disturbing the suction and discharge pipes and the driving motor (spacer type coupling required).
- Oversized shaft and bearing for continuous heavy duty version.
- Axial thrust bearing (pair of angular contact bearings) at drive side for handling high axial loads in both directions. Roller bearing at pump side.
- Dry shaft design protected by closed impeller nut and shaft sleeve.
- Shaft sealing: stuffing box with external flush or mechanical seals acc. to EN 12756 (DIN 24960), single mechanical seal internal arranged or double seal arrangements.

VOGEL - Pumps with Vortex Type Impeller, Design W



Performance Range:

Capacity up to 900 m³/h (3900 USgpm)
 Head up to 60 m (200 feet)
 Speed up to 1450 min⁻¹ (1450 r.p.m.)

Sizes:

DN 100 up to DN 200 (4" up to 8") discharge

Temperature:

max. 120°C (250° F)

Casing pressure:

max. 10 bar (145 psig)

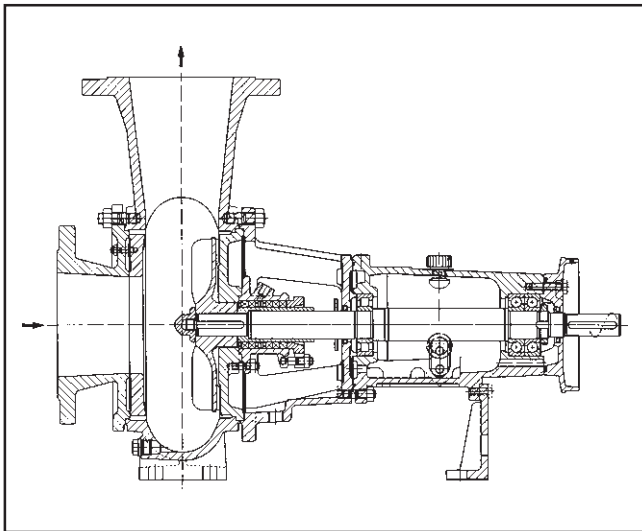

Liquids:

Contaminated liquids with solids and fibres
 Unscreened waste water, sludge up to 10 % atro
 Crystalline suspensions, effluent, etc.
 Paper pulp, beet slices

Applications:

Industrial or public waste and sewage plants
 Chemical industry
 Mining
 Sugar mills
 Food processing
 Pulp and paper mills

Materials:

Mat. Code	Impeller	Casing, Casing cover	Bearing frame, Lantern	Shaft	Shaft sleeve
N	Cast iron 0.6025	Cast iron 0.6025	Cast iron 0.6025	Stainl. steel 1.4021	Stainl. steel 1.4021
SN	Bronze 2.1050.01				
NL	Cast iron 0.6025				
VN	Stainl. steel 1.4408	Cast iron 0.6025			
VV		Stainl. steel 1.4408			Stainl. steel 1.4462

Other materials and special versions upon request

VOGEL - Pumps with Vortex Type Impeller, Design W

Performance Range:

1450 r.p.m.

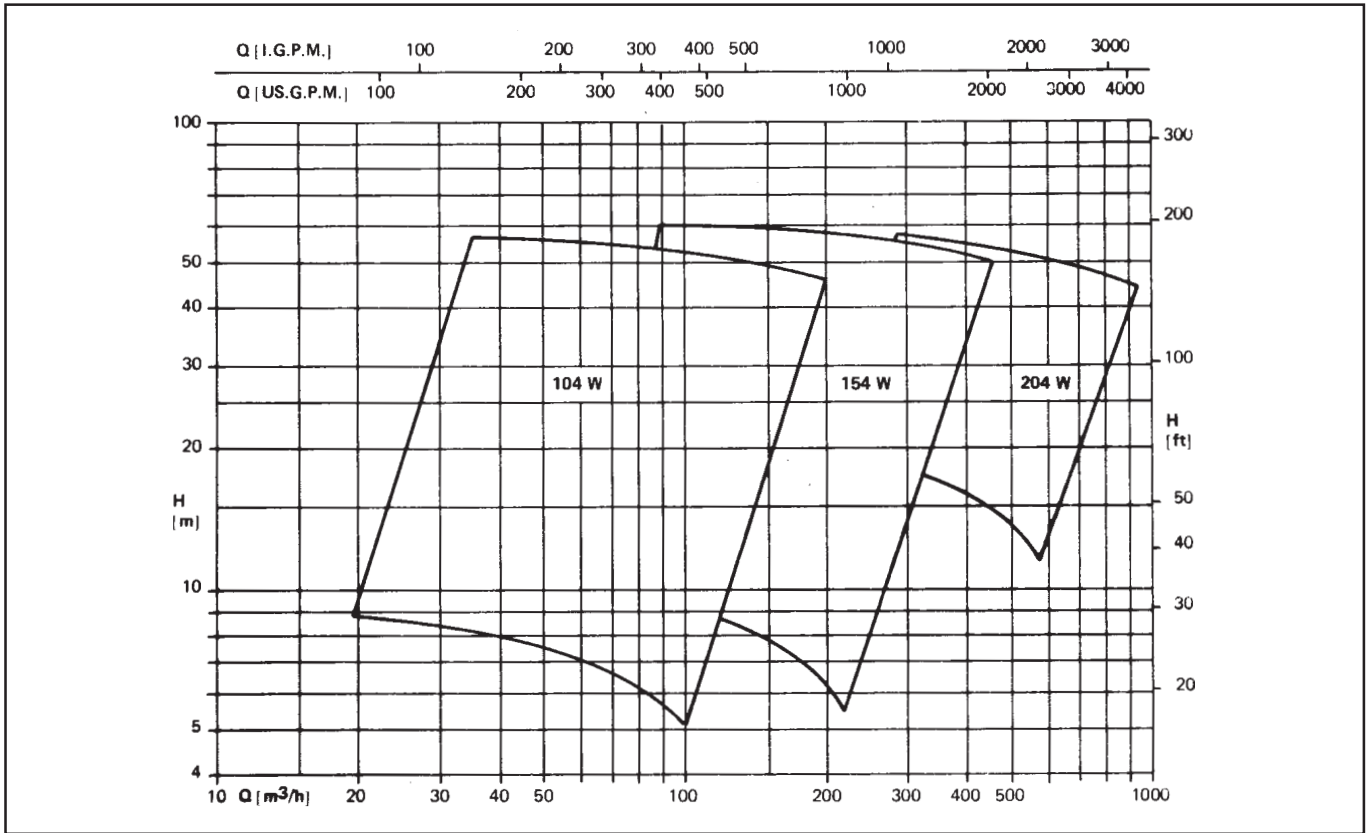

Performance Range:

950 r.p.m.

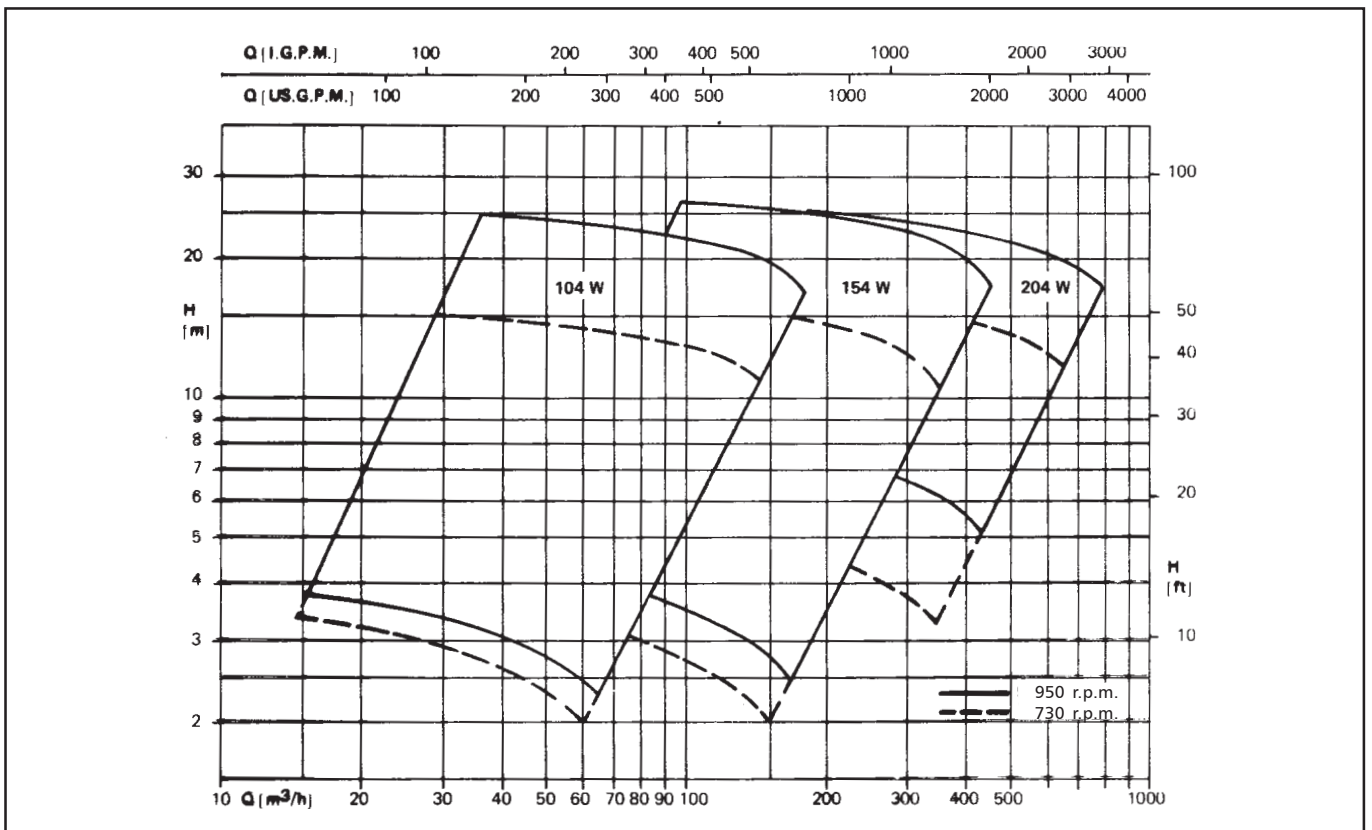

VOGEL - Pumps with Vortex Type Impeller, Design W

Design versions:

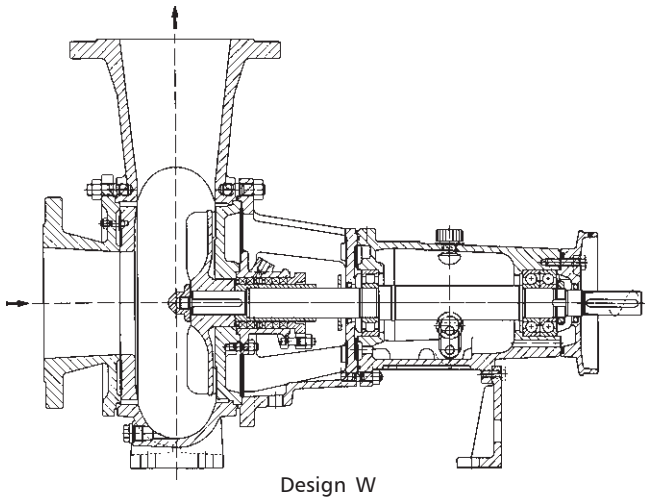

Design W:

Horizontal pump with vortex type impeller and oil lubricated bearing frame. Easy maintenance by back pull out system, disassembling of impeller and bearing frame without disturbing the suction and discharge pipes and the driving motor (spacer type coupling required). Suction branch axial, discharge branch vertical upwards.

Electric drive through flexible coupling, pump and motor mounted on common base plate. Optional V-belt drive, reverse overhead mounted (huckepack design).

Design WV:

Vertical short shaft version for dry installation. Bearing frame grease lubricated powered by vertical flanged IEC motor resting on motor lantern either through flexible coupling or extended cardan shaft.

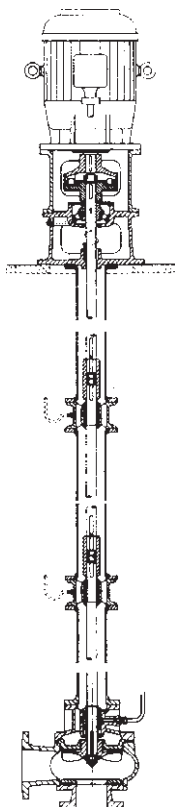
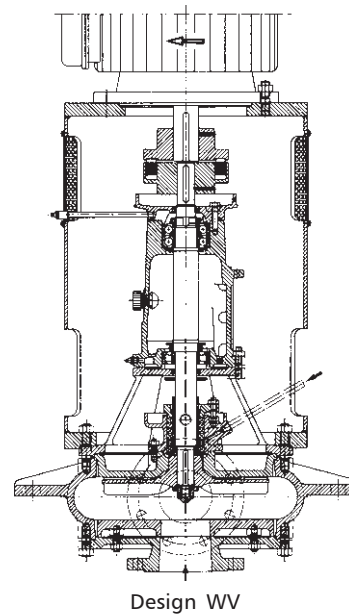

Design WT:

Vertical line shaft version for wet or dry installation. Drive head with motor lantern arranged above pump sump or pump floor. Radial bearings, sleeve bearing arranged in the column pipe. Lubrication by clear water.

Installation length up to 10 m.

VOGEL - Pumps with Vortex Type Impeller, Design W

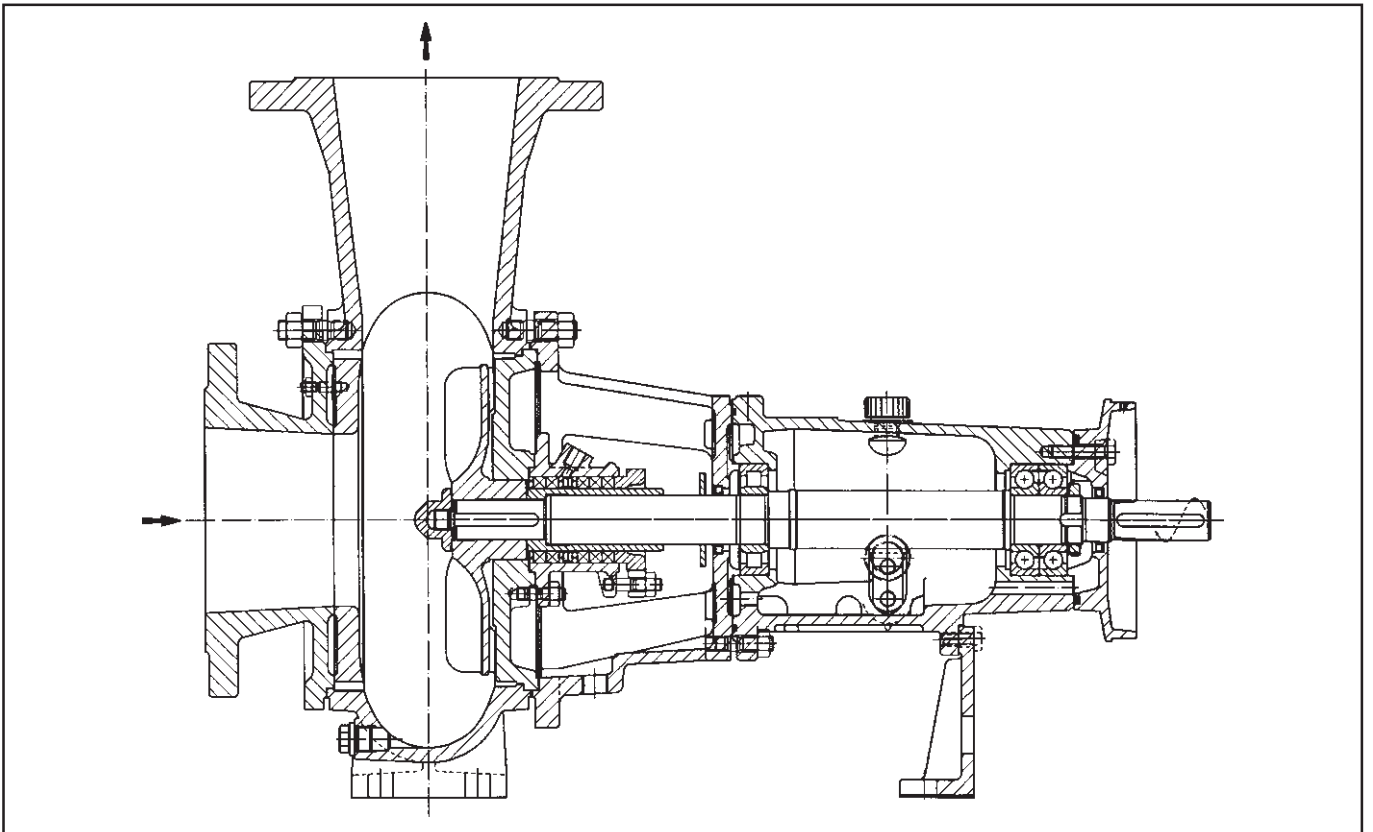

- Horizontal pump with vortex type impeller, clogless, large free passage for handling liquids containing solids and fibres.
- Easy maintenance by back pull out design, disassembling of impeller, shaft sealing and bearing frame without disturbing the suction and discharge pipes and the driving motor (spacer type coupling required).
- Oversized shaft and bearing for continuous heavy duty service.
- Axial thrust bearing (pair of angular contact bearings) at drive side for handling high axial loads in both directions. Roller bearing at pump side.
- Dry shaft design protected by closed impeller nut and shaft sleeve.
- Shaft sealing: stuffing box with external flush or mechanical seals acc. to EN 12756 (DIN 24960), single mechanical seal internal arranged or double seal arrangements.

VOGEL - Vertical Sump Pumps with Vortex Type Impeller, Design WTS



Performance Range:

Capacity up to 190 m³/h (840 USgpm)
Head up to 20 m (65 feet)
Speed up to 1450 min⁻¹ (1450 r.p.m.)

Sizes:

DN 100 (4") discharge

Temperature:

up to 95°C (200° F)

Design:

Vertical line shaft pump with vortex type impeller. Drive head with motor lantern arranged above pump sump. Radial bearings, sleeve bearings arranged in the column pipe (Bronze bushes and stainl. steel sleeves) lubricated by the handled liquid or optional by external clean water. Discharge connection above the pit cover. Standard length to fit into pits of 1000, 1500, 2000, 2500, 3000 or 3500 mm depth when allowing a distance of 100 mm between the pump suction and the pit bottom.

Liquids:

Clean and/or contaminated liquids containing solids and fibres.

Applications:

Clogging free dewatering of waste water pits in industry as sugar mills, food processing, paper mills, power stations a. s. o.

Materials:

Impeller and casing cast iron 0.6025.
Shaft and sleeve stainl. steel 1.4021.
Bearing bushes Bronze 2.1050.01.

Other materials upon request.

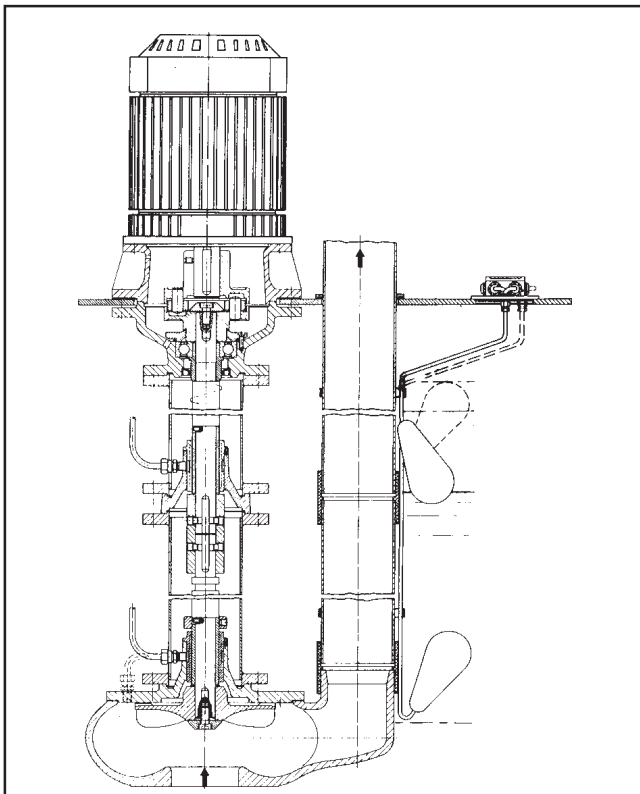

VOGEL - Vertical Sump Pumps with Vortex Type Impeller, Design WTS

Performance Range:

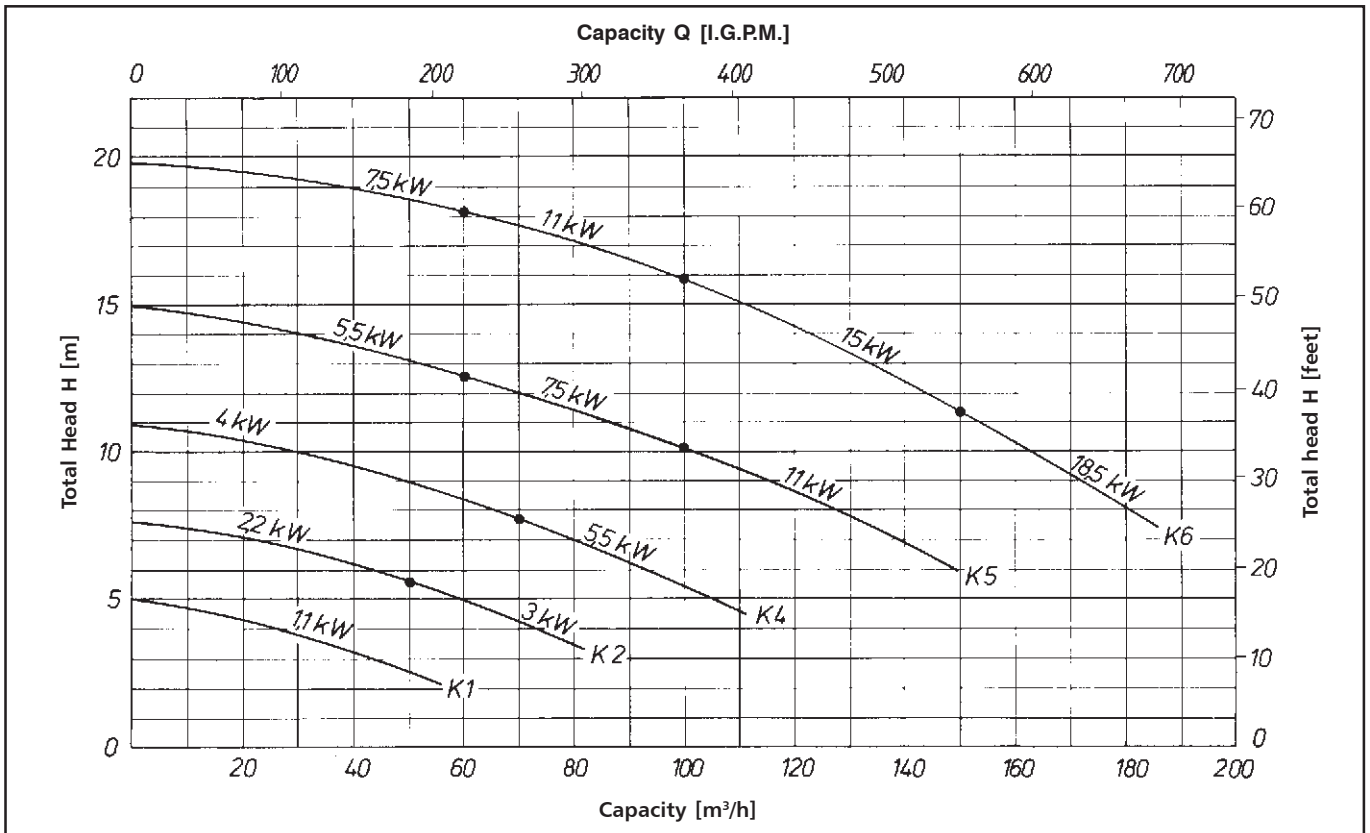

Pumpentype												
Einbautiefe 900 mm	21 . WTS 18	22 . WTS 15	24 . WTS 18	25 . WTS 20	26 . WTS 23							
Einbautiefe 1400 mm	31 . WTS 18	32 . WTS 15	34 . WTS 18	35 . WTS 20	36 . WTS 23							
Einbautiefe 1900 mm	41 . WTS 18	42 . WTS 15	44 . WTS 18	45 . WTS 20	46 . WTS 23							
Einbautiefe 2400 mm	51 . WTS 18	52 . WTS 15	54 . WTS 18	55 . WTS 20	56 . WTS 23							
Einbautiefe 2900 mm	61 . WTS 18	62 . WTS 15	64 . WTS 18	65 . WTS 20	66 . WTS 23							
Einbautiefe 3400 mm	71 . WTS 18	72 . WTS 15	74 . WTS 18	75 . WTS 20	76 . WTS 23							
Kennlinie	K 1		K 2		K 4		K 5		K 6			
Drehzahl ca. min ⁻¹	910		1420		1430		1450		1450		1460	
Motorleistung kW	1,1	2,2	3,0	4,0	5,5	5,5	7,5	11	7,5	11	15	18,5
Stromaufnahme bei 400 V ca. Amp.	3,12	4,83	6,58	8,7	11,5	11,5	15,3	23	15,3	23	30	38

Naming:

211 WTS 18 E 116
 212 WTS 18 E 116
 213 WTS 18 E 116

Version with internal lubrication by handled liquid
 Version with external clean water lubrication
 Version with external lubrication by grease

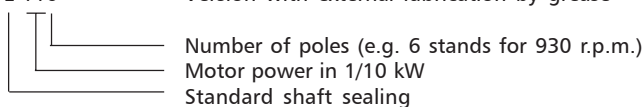



www.vogel-pumpen.com
www.hydrovar.com

Pumpenfabrik ERNST VOGEL GmbH

A-2000 Stockerau
Ernst Vogel-Straße 2
Telefon: 02266/604
Telefax: 02266/65 311
E-Mail: info@vogel-pumpen.ittind.com

Liability of manufacturer and/or supplier

The mentioned limits of operation and/or application are only a general information and may not be applied for every case. The permitted range of operation and/or application for the specific case is to be obtained from our acknowledgement of order and/or the instructions for installations, operation and maintenance, sent with the goods.

