

# MP 1, SQE-NE, SPA-NE, SP-NE

Submersible pumps, environmental  
50/60 Hz



# Contents

---

## General data

Performance range	3
Environmental concern	4
Product range and applications	5

## MP 1

General data	6
Technical data	8
Material specification (pump)	9
Material specification (motor)	9
Accessories	11

## SQE-NE

General data	13
Features and benefits	15
Examples of applications	18
Communication	25
Pump selection	30
Curve conditions	32
Technical data	38
Material specification (pump)	39
Material specification (motor)	39
Material specification (cable)	39
Accessories	41
Order data	43

## SPA-NE, SP-NE

General data	44
Features and benefits	47
Curve conditions	49
Technical data	58
Material specification (pump)	58
Material specification (motor)	58
Accessories	59
Central management system	65
Head losses in ordinary water pipes	68
Head losses in plastic pipes	69
Order data	70

## Pumped liquids

Resistance list	71
-----------------	----

## Further product documentation

WebCAPS	76
WinCAPS	77

## Performance range

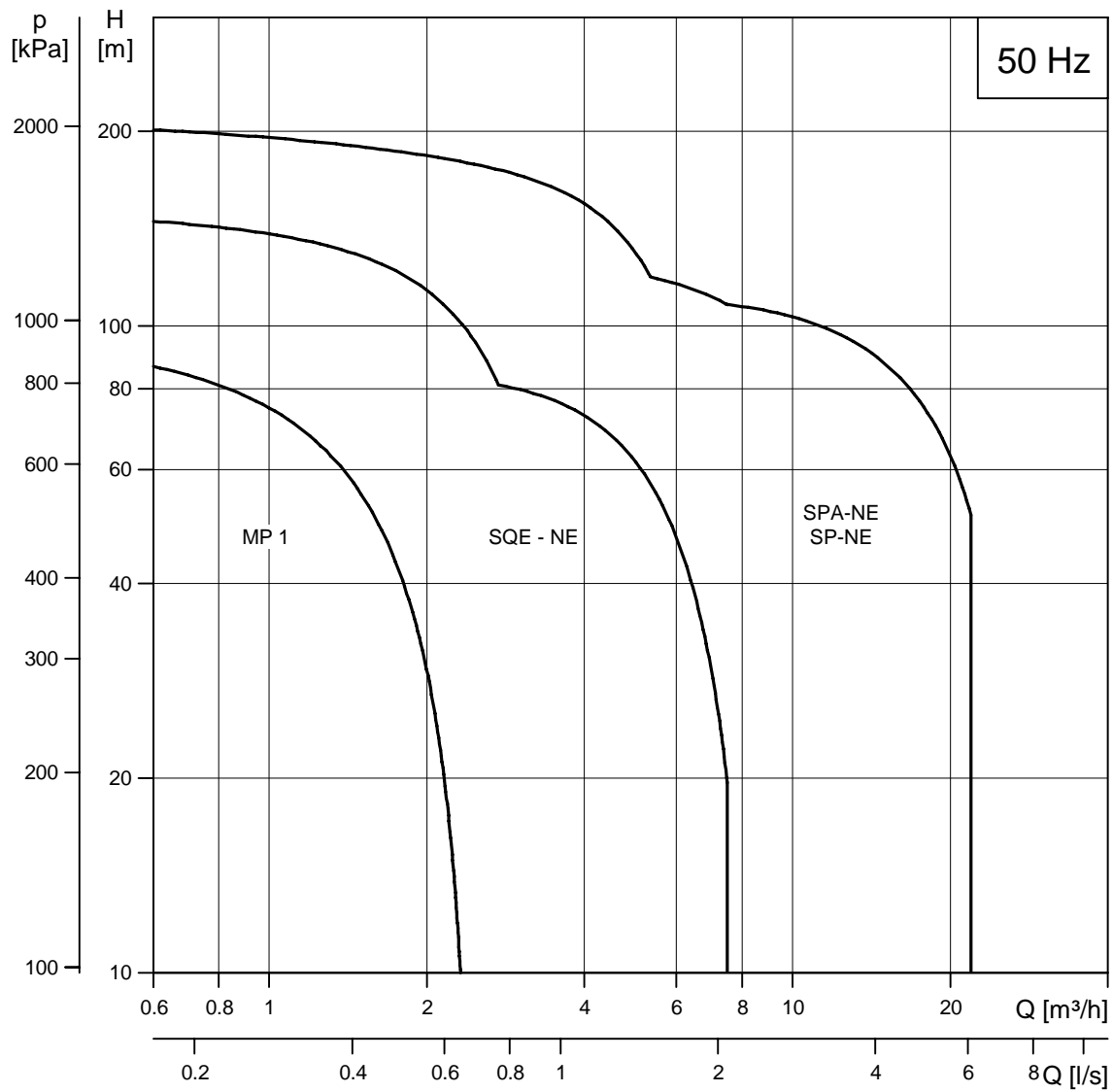

TM01 9132 0405

Fig. 1 Performance range

### Environmental concern

Concern for the environment is growing.

Waste disposal and treatment are being put into a legal framework.

Investment in environmental protection is on the increase and many sectors are taking concrete steps to develop new solutions to environmental problems.

To that end, Grundfos offers a complete product range for applications ranging from sampling to pumping of polluted drainage water.

#### Sources of pollution

Pollution of the groundwater and, thus, potential contamination of the drinking water resources can be caused by one or more of the following conditions:

- leaking pipes, storage tanks and sewage systems
- spills and leaks from tank lorries or wagons
- floods, landslides, etc.

In these cases, the potential damage to the environment can be minimised by pumping away the pollutants or the seepage water.

#### Industrial waste

Continuous and safe production in modern industry requires regulated disposal of waste. In the past, undesirable by products – such as residual materials or substances that could not be used, were often stored by companies on site. In the course of time, these materials and substances were often forgotten and some of them seeped into the ground.

Local authorities often have to deal with contaminated sites when the companies responsible for the contamination no longer exist or cannot afford the clean-up. Thanks to their high reliability and long life, Grundfos pumps offer a cost-effective solution.

### Sampling

The new Grundfos pump range featuring heads up to 200 m and flow rates up to 22 m<sup>3</sup>/h are suitable for sampling of seepage water and groundwater. In addition to various geophysical methods, boreholes can be drilled to determine the chemical nature of seepage water and groundwater in order to determine how serious the contamination is.

The Grundfos pumps are lowered into the borehole to pump up water for sampling. After the sampling, the pumps are pulled up again, cleansed and lowered into the next hole. Alternatively, the pumps are permanently installed in groundwater sampling wells for continuous duty.

### Industrial wastewater treatment

Many industries produce highly polluted effluent. The large factories typically have their own treatment plants, the size and capacity of which match the big city plants.

Today not only industrial process water but also cooling and surface water go through chemical and physical purification in separate systems before being led into a water treatment plant and then discharged or recycled into production.

Pumps are an important link between contaminated and re-usable water. A number of environmental protection plants only exists thanks to the development of special environmental pumps, such as the cost-effective, maintenance-free and highly reliable Grundfos MP 1, SQE-NE, SPA-NE and SP-NE range, based on up-to-date material combinations.



Fig. 2 MP 1, SQE-NE, SPA-NE and SP-NE pumps

TM02 02:49 0405

## Product range and applications



TM01 9174 1300



GR9407



TM01 9175 1300

Technical data	MP 1	SQE-NE	SPA-NE, SP-NE
Motor diameter	2"	3"	4"
Nominal flow rate [m <sup>3</sup> /h]	0.1 - 1	2 and 5	3 - 17
Max. head [m]	98	153	205
Motor power [kW]	1.3	0.6 - 1.7	0.75 - 5.5
Voltage supply [V]	1 x 220-240 V	1 x 200-240 V	1 x 220-230/240 V 3 x 200/220/380-415/500-525 V
Frequency [Hz]	50/60	50/60	50
Max. current [A]	5.5	11.2	13.0
Max. liquid temperature [°C]	35	40	40
<b>Applications</b>			
Sampling	●	●	●
Remedial pumping		●	●
Withdrawal of contaminated/polluted groundwater (from dumps, chemical depots, etc.)		●	●
Pumping in water treatment systems	●	●	●
Pumping of industrial process water		●	●
Water quality monitoring	●	●	●
<b>Mode of operation</b>			
Continuous		●	●
Intermittent	●	●	●

For further information about suitable pump types, see "Resistance list", page 73.

## MP 1

### General data

The MP 1 is an electrically driven 2" submersible pump for purging and sampling of contaminated/polluted groundwater.

The pump is driven via an adjustable MP 1 converter in the 50 to 400 Hz frequency range corresponding to a pump speed of max. 23,000 min<sup>-1</sup> and thus a nominal performance of 1 m<sup>3</sup>/h at 75 m head.

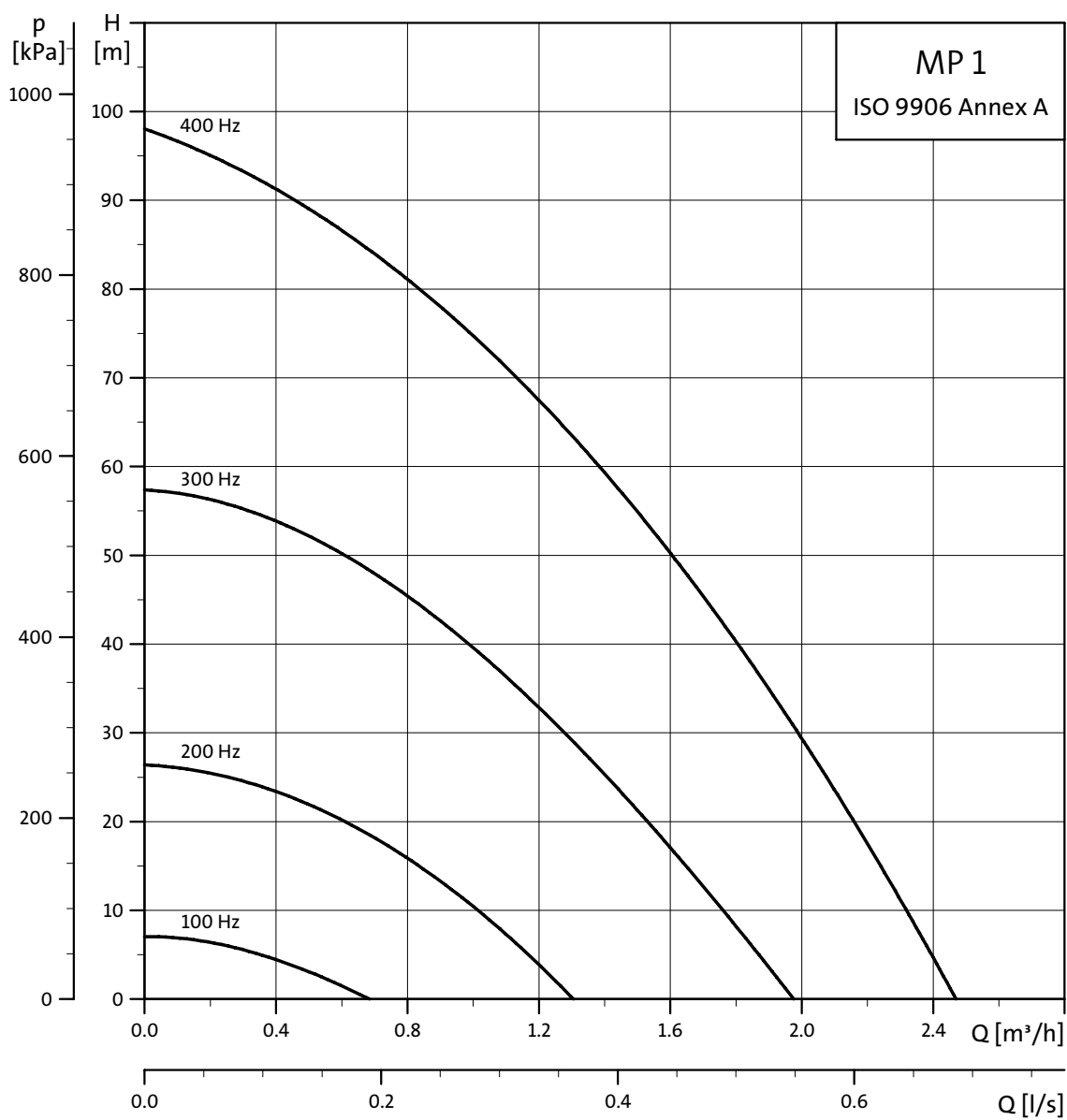

Fig. 3 Performance range

TM00 7778 2400

## Applications

The MP 1 is designed for the pumping of contaminated/ polluted groundwater for

- purging
- sampling
- water quality monitoring.

The MP 1 has been specially developed for sampling, i.e. pumping of small quantities of water to be sent to the laboratory for analysis in order to establish

- content of contaminants
- concentration of contaminants
- extension of contamination plume.

The MP 1 pump is made of inert materials, which do not affect the pumped liquid and thus the analysis results.

The pump performance is adjusted by means of the converter which controls the pump speed via the frequency. In this way a steady, airfree water flow can be achieved.

The MP 1 offers efficient purging of the well before sampling as a high pump performance is achieved when the frequency is raised. Maximum performance is at 400 Hz.

However, the pump must not pump more water than the well can yield. Otherwise, the water table may fall to a level below the suction interconnector and air will be sucked into the pump. Besides reducing the cooling of the motor, this situation may damage the pump. In order to avoid cleaning of the pump and possible cross-contamination, i.e. transfer of contaminants from one well to another, dedicated installation of the pump is recommended.

This also saves valuable time for the sampling technician as he can quickly disconnect the converter and proceed to the next MP 1 installation. The submersible drop cable is connected to the converter via a plug connection so that disconnection is possible without the use of tools.



Gr3101 - GrA6096

Fig. 4 MP 1 with converter

## Type key

Example	MP 1
Monitor pump	
Rated flow[m <sup>3</sup> /h]	

## Technical data

### Pumped liquids

Contaminated/polluted groundwater, i.e. thin, non-explosive liquids without abrasive particles or fibres.

Liquid temperature: 0 °C to +35 °C during operation.

Maximum sand content: 50 g/m<sup>3</sup>.

A larger sand content will reduce the life of service parts considerably.

**Note:** The MP 1 pump is not built for the pumping of concentrated hydrocarbons, chemicals or explosive liquids. As the pump has not been approved as explosion-proof, local authorities and regulations should be consulted in case of doubt whether the MP 1 pump may be used.

If the density or the kinematic viscosity is higher than that of water, a higher input power than the nominal power will be required, and the maximum number of revolutions must therefore be reduced.

### Overload protection

As the motor and converter have overload protection, the maximum output at which the overload protection does not switch off can be found through a trial-and-error procedure. Restart of the pump after switch-off requires resetting of the converter on the start/stop switch located on the front cover of the converter.

### Product range

The MP 1 is available in one size for connection to a MP 1 converter and for Rp 3/4 pipe connection. The pump can be delivered from factory with or without motor liquid (demineralized water). The pump is fitted with various motor cable lengths, according to the table below.

Motor cable length [m]	Product number MP 1 incl. cable, connecting thread Rp 3/4	
	Without motor liquid	With motor liquid
10	95065394	1A105103
20	95065395	1A105203
30	95065396	1A105303
40	95065397	1A105403
50	95065398	1A105503
60	95065399	1A105603
70	95065400	1A105703
80	95065401	1A105803
90	95065402	1A105903

The MP 1 must be operated via a MP 1 converter which is custom-built to Grundfos specifications.

The converter is supplied without cable and plug for mains connection.

Designation	Product number
MP 1 converter	96765942
MP 1 converter incl. cabinet	96765948
MP 1 converter incl. 2 m cable and schuko plug	96835207
MP 1 converter incl. cabinet, 2 m cable and schuko plug	96824721



### Material specification (pump)

Pos.	Components	Materials	DIN W.-Nr.
201a	Pump housing	Stainless steel	1.4401
232	Guide vane	Stainless steel	1.4401
230	Intermediate ring	Stainless steel	1.4401
285	Washer	PTFE	
213	Impeller	Stainless steel	1.4401
207	Neck ring	PTFE	
215	Suction strainer	Stainless steel	1.4401
214	Suction interconnector	Stainless steel	1.4401

### Material specification (motor)

Pos.	Components	Materials	DIN W.-Nr.
2	Rotor	Magnetic PTFE-coated steel sheets embedded with aluminium	
	Shaft	Stainless steel	1.4460
	Radial bearing, rotating	Tungsten carbide	
2a	Thrust washer	PTFE	
2b			
32	Seal ring	FKM	
12, 24, 74a	O-rings	FKM	
4, 5	Radial bearings, stationary	Stainless steel Ceramics	1.4401
1	Stator		
	Rotor can	Stainless steel	1.4401
	Stator housing	Stainless steel	1.4401
73, 222	Screws	Stainless steel	1.4401
20	Motor cable (4 x 1 mm <sup>2</sup> )	ETFE/FEP (Tefzel)	
	Cable screws	Stainless steel	1.4401
	Washers	PTFE/brass	
	Cable seal bushes	FKM	
	Plug pins	Goldplated brass	
74	Filling screw (for motor liquid)	Stainless steel	1.4460

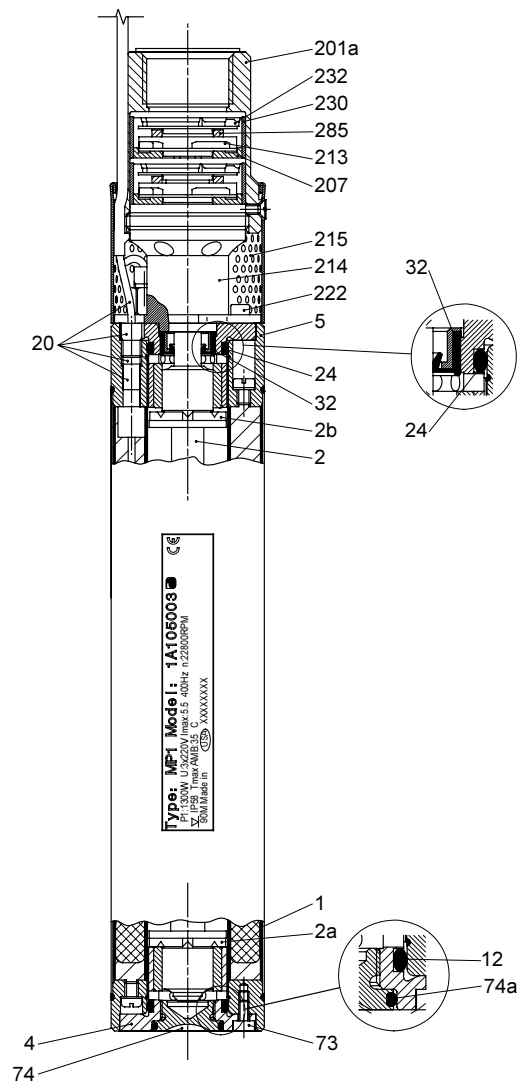

Fig. 5 MP 1

TM00 0530 3100

### MP 1

Power consumption:	1.3 kW
Voltage:	3 x 220 V, 400 Hz
Current:	Max. 5.5 A
Motor protection:	Built-in thermal switch.
Water temperature:	0 °C to +35 °C.
Continuous operation:	Maximum 500 hours.
Pipe connection:	Rp 3/4
Net weight (pump only):	2.5 kg.

### MP 1 converter

Supply voltage:	1 x 220-240 V – 15 %/+ 10 %, 50/60 Hz, PE
Minimum generator size:	With voltage control: 2.5 kVA. 4.0 kVA (recommended size).  Without voltage control: 5.0 kVA.
Rated current:	10 A
Power factor:	0.65
Connecting cable:	3 x 1.5 mm <sup>2</sup> 3 m with plug
Output voltage:	3 x 25 V, 50 Hz to 3 x 210 V, 400 Hz
Motor protection:	Built-in overcurrent protective device, set to 6.1 A.
Acceleration time:	0 to 400 Hz: Max. 6 sec.
Deceleration time:	400 to 0 Hz: Max. 6 sec.
Enclosure class:	IP 65.
Ambient temperature during operation:	–10 °C to 45 °C.
Relative air humidity:	Maximum 95 %.
Net weight:	7.7 kg.

### Service

Only pumps that can be certified as uncontaminated, i.e. pumps containing no hazardous and/or toxic material, may be returned to Grundfos for servicing.

To prevent injury to the health of persons involved and to the environment, a document certifying that the pump is clean is required.

Grundfos must receive this certificate before the product. Otherwise Grundfos will refuse to accept the product for servicing. Possible costs of returning the product are paid by the customer.

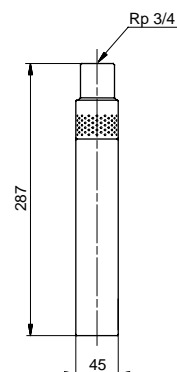

Fig. 6 MP 1 dimensions

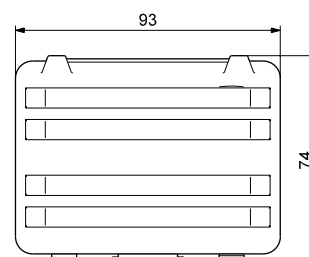
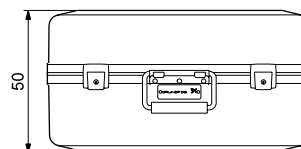
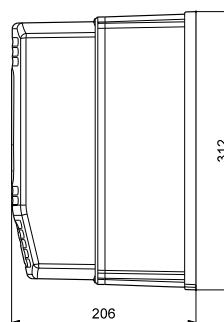
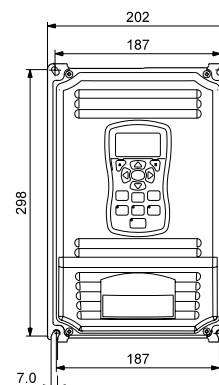

Fig. 7 Converter dimensions

TM00 0531 0894

TM04 1456 1008 - TM04 1757 1008

## Accessories

### Converter cabinet

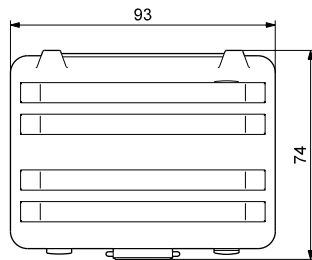
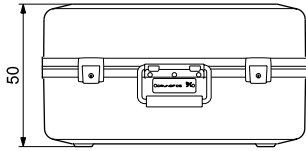

TM04 1757 1008

Description	Product number
Facilitates handling of the converter and protects it against sprinkles and splashes of water.	96765941
Enclosure class: IP 65.	

### Straining wire

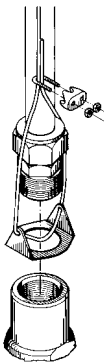

TM00 0875 4092

Description	Length [m]	Product number
If a flexible hose is connected to the pump, the use of a straining wire is recommended to prevent the pump from being dropped into the well or the motor cable from being damaged in case the hose stretches.  The wire is supplied with 2 wire locks.  Diameter: 2.3 mm.  Material: Stainless steel DIN W.-Nr. 1.4401, AISI 316.	10	1A5051
	20	1A5052
	30	1A5053
	40	1A5054
	50	1A5055
	60	1A5056
	70	1A5057
	80	1A5058
	90	1A5059
Separate wire lock.		ID5746

### Wire holder for straining wire

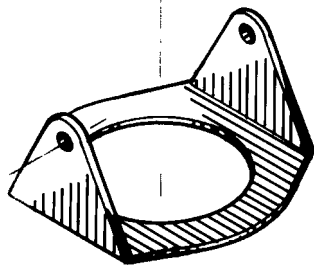

TM00 1277 4892

Description	Connecting thread	Product number
The wire holder is fitted direct on top of the pump and fastened by means of the riser pipe or a hose union.  Material: Stainless steel DIN W.-Nr. 1.4401, AISI 316.	Rp 3/4	1A0018

## Flexible hose

Description	Length [m]	Product number
Diameter: 18/13 mm. Material: PTFE transparent. Pressure: Max. 10 bar.	10	1A0081
	20	1A0082
	30	1A0083
	40	1A0084
	50	1A0085
	60	1A0086
	70	1A0087
	80	1A0088
	90	1A0089

## Coupling for flexible hose

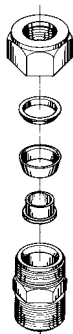

TM00 1278 4992

Description	Connecting thread	Product number
The flexible hose is available with Rp 3/4 compression coupling fitting.  Material: Stainless steel DIN W.-Nr. 1.4401, AISI 316.	Rp 3/4	1A5030

## Flow sleeve



TM00 1286 4992

Description	Product number
If the internal borehole diameter exceeds 80 mm, the pump can be fitted with a flow sleeve to ensure cooling of the motor.  External diameter: 55 mm.  Total length: 310 mm.  Material: Stainless steel DIN W.-Nr. 1.4401, AISI 316.	1A108405

## SQE-NE

### General data

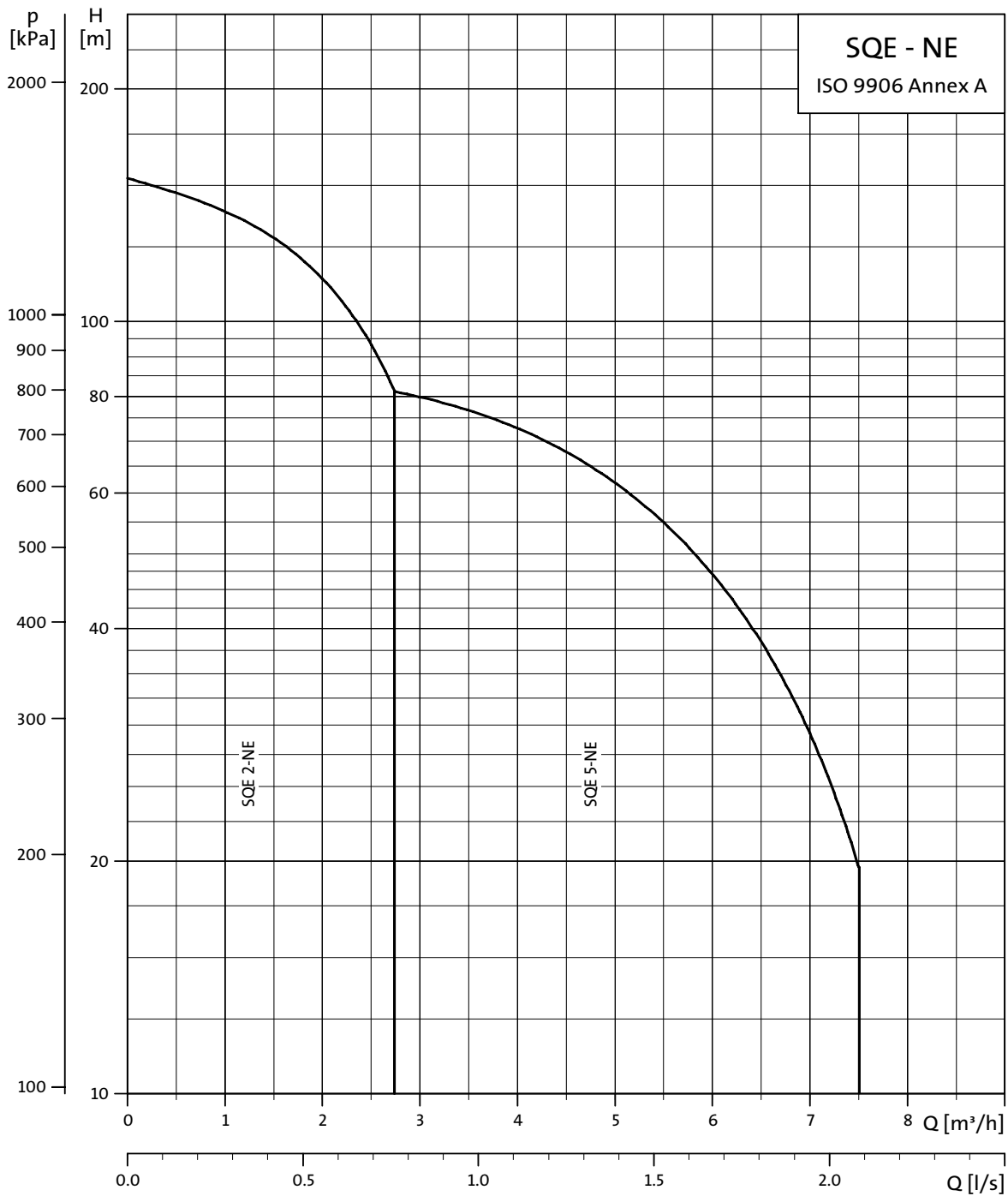

TM01 9343 3704

Fig. 8 Performance range

### Applications

SQE-NE pumps are suitable for the following applications

- sampling
- remedial pumping
- withdrawal of contaminated water at
  - dumps
  - chemical depots
  - industrial sites
  - garages and filling stations
- pumping in water treatment systems
- pumping of industrial process water
- water quality monitoring.

SQE-NE pumps are built for both continuous and intermittent operation.

**Note:** For other applications, please contact Grundfos.

### Pump and motor

SQE-NE pumps offer the following features:

- dry-running protection
- high efficiency of pump and motor
- wear resistance
- protection against upthrust
- soft starting
- overvoltage and undervoltage protection
- overload protection
- overtemperature protection
- variable speed
- electronic control and communication.

The submersible SQE-NE pump is fitted with a single-phase Grundfos MSE 3-NE motor, which is available in three sizes with a maximum power  $P_2$  of 1.7 kW.

The MSE 3-NE permanent magnet motors are based on state-of-the-art technology, which is the main reason for their high efficiency. The integrated electronic unit of the motors comprises a frequency converter for soft starting.

The SQE-NE pump features variable speed which is offered through frequency control. Consequently the pump can be set to operate in any duty point in the range between the min. and max. pump performance curves.

The SQE-NE pump features communication with the Grundfos CU 300 control unit, which can be operated with the Grundfos R100 remote control.

The SQE-NE pump can also operate without the CU 300.

The CU 300 provides full control of the SQE-NE pump. In case of a pump fault, an alarm will be indicated on the front of the CU 300.

The R100 enables monitoring of the installation and changing of the factory settings.

### Pump and motor range

Product	Description	Material
SQE-NE pump	2 and 5 m <sup>3</sup> /h	Stainless steel DIN 1.4401, AISI 316
MSE 3-NE motor	Single-phase max. 1.7 kW	Stainless steel DIN 1.4401, AISI 316

### Pipe connection

Pump type	Threaded connection
SQE 2-NE	Rp 1 1/4
SQE 5-NE	Rp 1 1/2

### Type key

Example	SQ	E	2	-50	NE
Pump range					
E = Electronic control and communication					
Rated flow [in m <sup>3</sup> /h]					
Head at rated flow [in mm]					
Material code:					
N = Stainless steel DIN W.-Nr. 1.4401					
E = Environmental.					
The pump is suitable for pumping of polluted liquids					

### Pumped liquids

The SQE-NE pump is suitable for use with slightly aggressive liquids such as contaminated groundwater and groundwater containing hydrogen carbonate.

SQE-NE pumps can pump liquids with a sand content of up to 50 g/m<sup>3</sup>. A higher content of sand will reduce the pump life.

### Operating range

Flow: 0.3 to 7.5 m<sup>3</sup>/h

Head: Max. 153 m.

## Features and benefits

### Dry-running protection

The SQE-NE pumps are protected against dry running. A factory-set  $P_{\text{cut-out}}$  value ensures cut-out of the pump in case of lack of water in the borehole thus preventing a burnout of the motor.

### High pump efficiency

The hydraulic pump components are PVDF CN-F reinforced with 10 % carbon fibre. The hydraulic design gives high pump efficiency meaning low energy consumption and therefore low energy costs.

### High motor efficiency

The MSE 3-NE motor is based on a permanent-magnet rotor (PM motor) featuring high efficiency within a wide load range.

The high, flat efficiency curve of the PM motor enables the same motor to cover a wide power range compared to conventional AC motors. For SQE-NE pumps, this means fewer motor variants.

### Wear resistance

The SQE-NE pump design features impellers which are not fastened to the shaft ("floating"). Each impeller has its own tungsten-carbide/ceramic bearing. The design and materials chosen ensure high wear resistance to sand for long product life.

### Protection against upthrust

Starting up a pump with a very low counter-pressure involves the risk of the entire impeller stack being lifted – also called upthrust. Upthrust may cause breakdown of both pump and motor. The MSE 3-NE is fitted with a top bearing protecting both pump and motor against upthrust and thus preventing breakdown during the critical start-up phase.

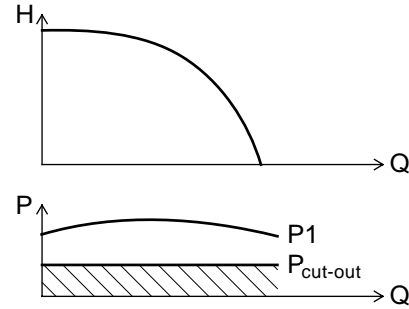

Fig. 9 Dry-running protection

TM01 2751 2298

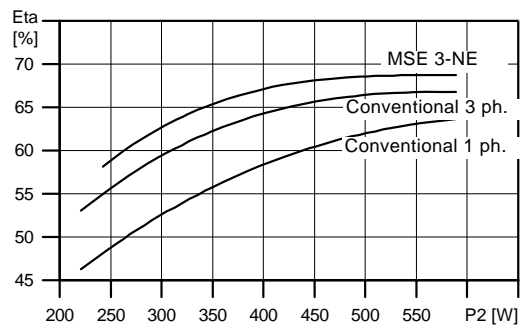

Fig. 10 Motor efficiency

TM01 2698 2298



Fig. 11 Pump parts including bearings

TM01 3141 3498

## Excellent starting capabilities

The integrated electronic unit of the MSE 3-NE motors features soft starting. Soft start reduces the starting current and thus gives the pump a smooth and steady acceleration.

The soft starter minimises the risk of pump wear and prevents overloading of the mains during start-up.

The excellent starting capabilities are a result of the high locked-rotor torque of the permanent-magnet motor together with the few pump stages. The high starting reliability also applies in case of low voltage supply.

## Overvoltage and undervoltage protection

Overvoltage and undervoltage may occur in case of unstable voltage supply.

The integrated protection of the MSE 3-NE motors protects the motor in case the voltage falls outside the permissible voltage range.

The pump will be cut out if the voltage falls below 150 V or rises above 315 V. The motor is automatically cut in again when the voltage is again within the permissible voltage range. Therefore, no extra protection relay is needed.

## Overload protection

Exposure of the pump to heavy load causes the current consumption to rise. The motor will automatically compensate for this by reducing the speed to 3000 rpm. Further overload will lead to stop.

The same applies if the rotor is being prevented from rotating. This will automatically be detected and the power supply cut out. Consequently, no extra motor protection is required.

## Overtemperature protection

A permanent-magnet motor gives off very little heat to its surroundings. In combination with an efficient internal circulation system providing cooling of the rotor, stator and bearings, this ensures optimum operating conditions for the motor.

As extra protection, the electronic unit has a built-in temperature sensor. When the temperature rises too high, the motor is cut out. When the temperature has dropped, the motor is automatically cut in again.

## Reliability

Designed with a view to high reliability, the MSE 3-NE motors offer the following features

- tungsten-carbide/ceramic bearings
- thrust bearings protecting against downthrust
- product life time equal to conventional AC motors.

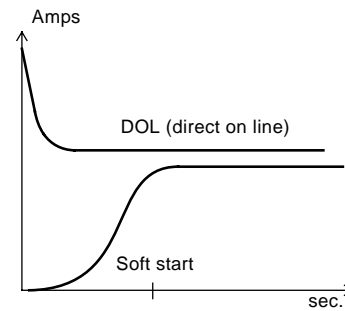

Fig. 12 DOL versus soft starting

TM01 3479 4198



## Variable speed

The MSE 3-NE motor enables continuously variable speed control between the 3000 and 10700 rpm. The pump can be set to operate in any duty point in the range between the 3000 and 10700 rpm performance curves of the pump. Consequently, the pump performance can be adapted to any specific requirement.

The variable-speed control facility requires the use of the CU 300 or CU 301 control unit and the R100 remote control.

For the calculation of pump speed, the PC tool "SQE speed calculation" is available on CD-ROM as an accessory, see page 42. On the basis of a required head and flow, the speed of the motor is calculated. Furthermore, the specific pump performance curve can be illustrated.

## Installation

The SQE-NE is suitable for vertical and horizontal installation or any position inbetween.

**Note:** The pump must never be installed below the horizontal plane in relation to the motor.

The following features ensure simple installation of the SQE-NE pumps:

- Built-in non-return valve with spring.
- Low weight for user-friendly handling.
- Installation in 3" or larger boreholes.
- Only an on/off switch is required, meaning that there is no need for motor starter or starter box.
- A cable with plug is available on request (up to 80 m).

For horizontal installation a flow sleeve is recommended

- to ensure sufficient flow velocity past the motor and thus provide sufficient cooling and
- to prevent the motor and electronic unit from being buried in sand or mud.

## Service

The modular pump and motor design facilitates installation and service. The cable with plug is fitted to the pump with screws, which facilitates replacement.

Only pumps that can be certified as uncontaminated, i.e. pumps containing no hazardous and/or toxic material, may be returned to Grundfos for servicing.

To prevent injury to the health of persons involved and to the environment, a document certifying that the pump is clean is required.

Grundfos must receive this certificate before the product. Otherwise Grundfos will refuse to accept the product for servicing. Possible costs of returning the product are paid by the customer.

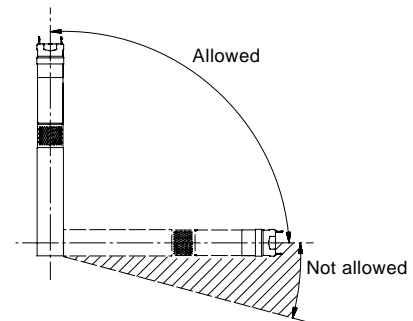

TM01 1375 1498

Fig. 13 Installation of SQE-NE pumps

## Examples of applications

### Sampling at variable speed

#### Function and benefits

The SQE-NE pump is ideally suited for the sampling of water as the pump materials are resistant to aqueous solutions of chemicals, oils, etc.

Prior to sampling, the well must be purged several times at high pump speed to make sure that the sample is representative. Subsequently the sample must be taken at low pump speed in order not to affect the quality of the water and to avoid degassing.

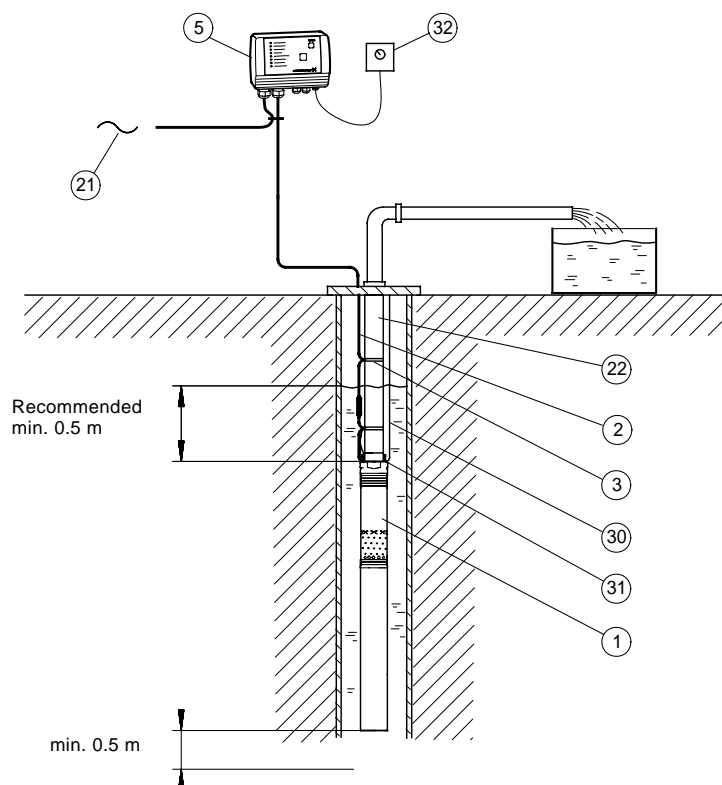

- 1 SQE-NE pump
- 2 Cable
- 3 Cable clips
- 5 CU 300 control unit
- 21 Mains connection, 1 x 200-240 V, 50/60 Hz
- 22 Riser pipe
- 30 Straining wire
- 31 Wire clamp, 2 per lifting eye
- 32 SPP 1 potentiometer

Fig. 14 Sampling at variable speed

### Sampling at variable speed

Pos.	Part	Type	No. of units	Product number	Unit price	Total price
1	Pump	SQE-NE				
2	Cable					
3	Cable clips					
5	Control unit	CU 300				
22	Riser pipe					
30	Straining wire					
31	Wire clamp		2 per lifting eye			
32	Potentiometer	SPP 1				

TM01 9028 1000

## Dewatering system

### Function and benefits

The dewatering system is ideal in applications where the pump often runs dry, e.g. in boreholes with a low yield or in boreholes where the water table should be lowered, e.g. in a building site.

Air entering the pump together with water due to a drop in the water level causes the motor load and, consequently, the pump power input to decrease.

If the pump power input falls below a minimum power limit set via the R100, the pump stops.

The pump setting can be made in a workshop by means of a CU 300, and subsequently the pump can be installed in the borehole. If the setting is made in this way, it is not necessary to include the CU 300 in the application below.

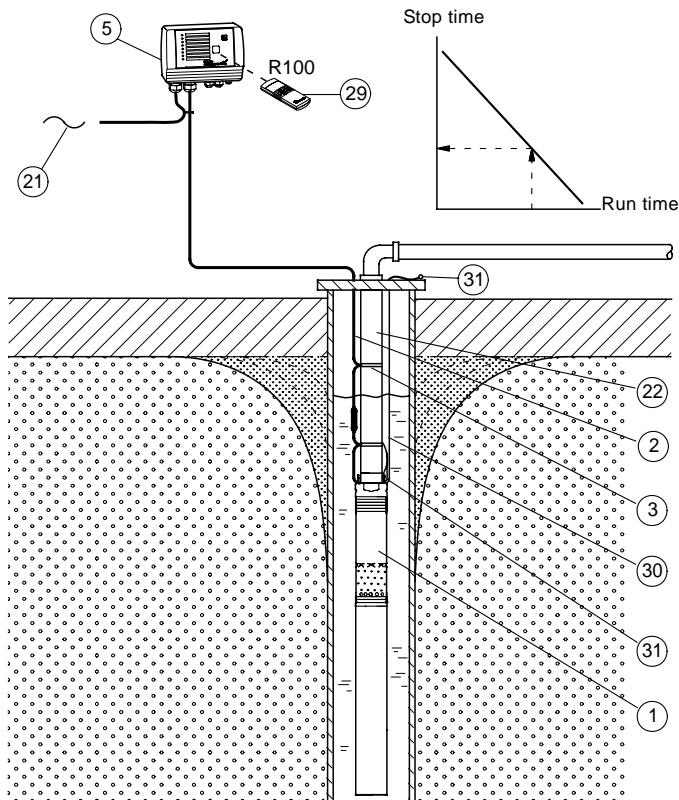

- 1 SQE-NE pump
- 2 Cable
- 3 Cable clips
- 5 CU 300 control unit
- 21 Mains connection, 1 x 200-240 V, 50/60 Hz
- 22 Riser pipe
- 29 R100 remote control
- 30 Straining wire
- 31 Wire clamp

Fig. 15 Dewatering system

### Dewatering system

Pos.	Part	Type	No. of units	Product number	Unit price	Total price
1	Pump	SQE-NE				
2	Cable					
3	Cable clips					
5	Control unit	CU 300				
22	Riser pipe					
29	Remote control	R100				
30	Straining wire					
31	Wire clamp					

TM01 9412 1900

## Maintaining a constant water table

### Functioning and benefits

The water table can be maintained at a constant level by adjusting the pump performance. For example, maintaining a constant water table is useful when the groundwater should be kept out of a building site or when salt water should be kept from penetrating a borehole containing potable water.

The example shows how to maintain a constant water table by adjusting the pump performance. At low or no flow and thereby low performance, the flowmeter ensures that the pump stops in order to avoid overheating of the motor.

### Sensors

Level	Description	Reaction
Level sensor (pos. 11)		
Warning (max.)	Too high water level. Possible cause: Insufficient pump capacity.	Alarm relay operates.
Desired level	The water level that should be maintained.	
Warning (min.)	Too low water level. Possible cause: Too high pump capacity.	Alarm relay operates.

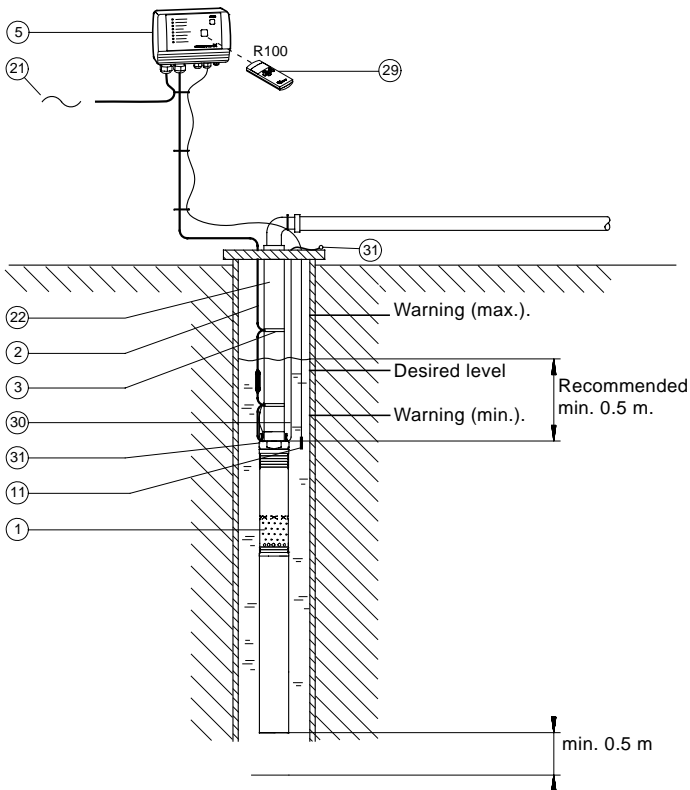

- 1 SQE-NE pump
- 2 Cable
- 3 Cable clips
- 5 CU 300 control unit
- 11 Level sensor
- 21 Mains connection, 1 x 200-240 V, 50/60 Hz
- 22 Riser pipe
- 29 R100 remote control
- 30 Straining wire
- 31 Wire clamp

Fig. 16 Maintaining a constant water table

### Maintaining a constant water table

Pos.	Part	Type	No. of units	Product number	Unit price	Total price
1	Pump	SQE-NE				
2	Cable					
3	Cable clips					
5	Control unit	CU 300				
11	Level sensor					
22	Riser pipe					
29	Remote control	R100				
30	Straining wire					
31	Wire clamp					

TM01 2459 4801

## Systems with three sensors connected

### Function and benefits

The CU 300 enables systems with three sensors connected.

### Sensors

Level	Description	Reaction
pH sensor on ground (pos. 33)		
Warning	The pH value is close to the maximum value allowed.	Alarm relay operates.
Alarm	The pH value has reached the maximum value allowed.	The pump is stopped. The indicator light "sensor alarm" is on.

Level	Description	Reaction
Level sensor in borehole (pos. 11)		
Warning (top)	Too high water level. Possible cause: Insufficient pump capacity.	Alarm relay operates.
Max. (start)	When the water has reached this level, the pump starts.	Green indicator light in on/off button is constantly on.
Min. (stop)	When the water has reached this level, the pump stops.	Green indicator light in on/off button flashes.
Warning (bottom)		
Warning (bottom)	Too low water level in borehole. Possible cause: Pumping in adjacent boreholes.	Alarm relay operates.

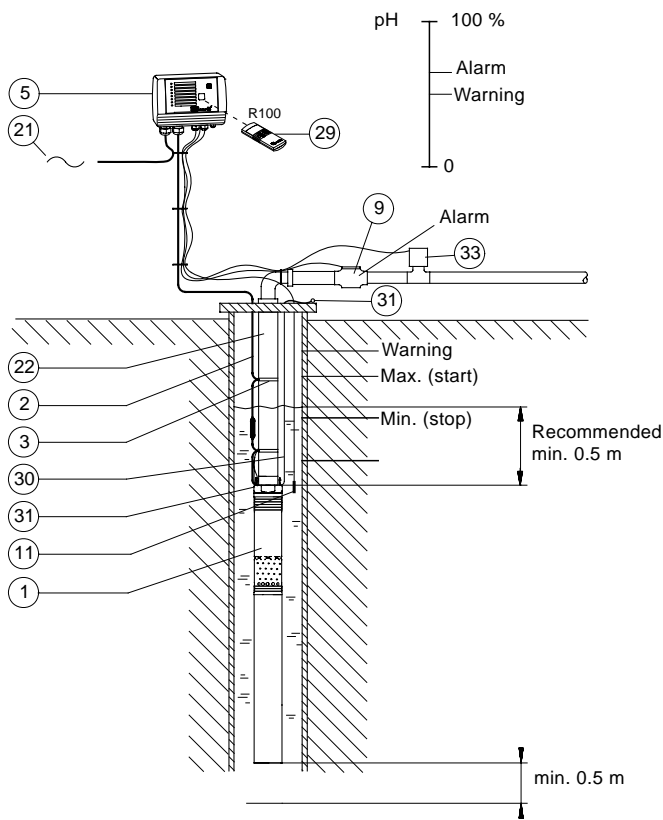

- 1 SQE-NE pump
- 2 Cable
- 3 Cable clips
- 5 CU 300 control unit
- 9 Pulse flowmeter
- 11 Level sensor
- 21 Mains connection, 1 x 200-240 V, 50/60 Hz
- 22 Riser pipe
- 29 R100 remote control
- 30 Straining wire
- 31 Wire clamp
- 33 pH sensor

Fig. 17 Systems with three sensors connected

## Systems with three sensors connected

Pos.	Part	Type	No. of units	Product number	Unit price	Total price
1	Pump	SQE-NE				
2	Cable					
3	Cable clips					
5	Control unit	CU 300				
9	Pulse flowmeter					
11	Level sensor					
22	Riser pipe					
29	Remote control	R100				
30	Straining wire					
31	Wire clamp					
33	pH sensor					

TM01 9394 1800

## Filling a tank from borehole using level control

### Function and benefits

The SQE-NE pump with CU 300 is ideal for filling a tank from a borehole.

### Sensors

Level	Description	Reaction
Level sensor in tank (pos. 11)		
Warning (top)	Too high water level, e.g. due to rainwater in tank.	Alarm relay operates.
Max. (stop)	When the water has reached this level, the pump stops.	Green indicator light in on/off button flashes.
Min. (start)	When the water has reached this level, the pump starts.	Green indicator light in on/off button is constantly on.
Warning (bottom)	Too low water level, e.g. due to a too small pump performance.	Alarm relay operates.
Level sensor in borehole (pos. 12)		
Alarm	Too low water level, e.g. due to a too small pump performance.	The pump stops. Alarm relay operates, and the indicator light "sensor alarm" is on.

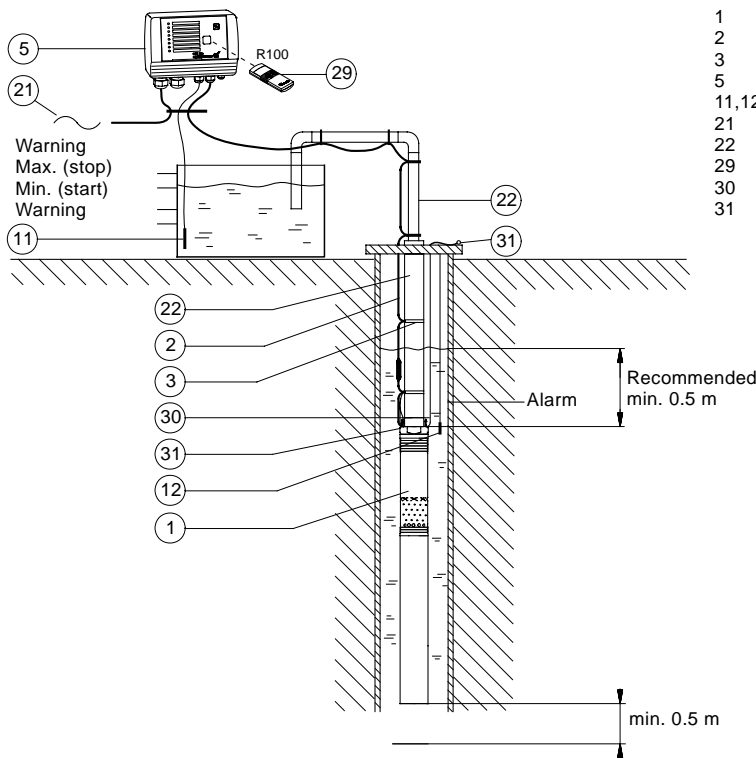

- 1 SQE-NE pump
- 2 Cable
- 3 Cable clips
- 5 CU 300 control unit
- 11, 12 Level sensor
- 21 Mains connection, 1 x 200-240 V, 50/60 Hz
- 22 Riser pipe
- 29 R100 remote control
- 30 Straining wire
- 31 Wire clamp

Fig. 18 Filling a tank from borehole using level control

## Filling a tank from borehole using level control

Pos.	Part	Type	No. of units	Product number	Unit price	Total price
1	Pump	SQE-NE				
2	Cable					
3	Cable clips					
5	Control unit	CU 300				
11	Level sensor					
12	Level sensor					
22	Riser pipe					
29	Remote control	R100				
30	Straining wire					
31	Wire clamp					

TM01 9395 1800

## Remedial pumping with water quality monitoring

### Function and benefits

By means of sensor communication, it is possible to carry out remedial pumping of liquids such as water-soluble chemicals, oils, etc.

Remedial pumping is carried out, for example, in connection with the treatment of the groundwater surrounding a dump. The process can involve both recovery and treatment by separating the chemicals or oil from the recovered water. Subsequently the water is led back into the ground.

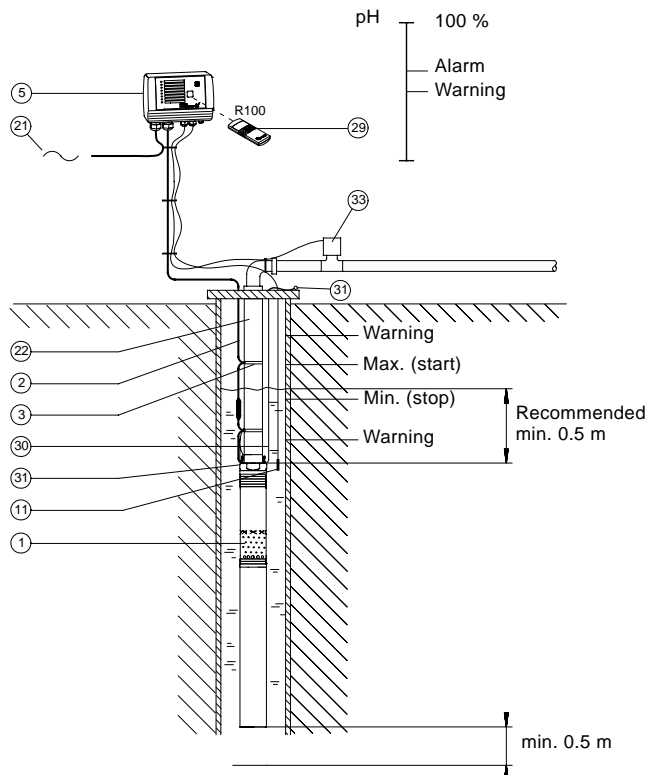

Fig. 19 Remedial pumping with water quality monitoring

### Remedial pumping with water quality monitoring

Pos.	Part	Type	No. of units	Product number	Unit price	Total price
1	Pump	SQE-NE				
2	Cable					
3	Cable clips					
5	Control unit	CU 300				
11	Level sensor					
22	Riser pipe					
29	Remote control	R100				
30	Straining wire					
31	Wire clamp					
33	pH sensor					

### Sensors

Level	Description	Reaction
Level sensor in borehole (pos. 11)		
Warning (top)	Too high water level in borehole. Possible cause: Insufficient pump capacity.	Alarm relay operates.
Max. (start)	When the water reaches this level, the pump starts.	Green indicator light in on/off button is constantly on.
Min. (stop)	When the water reaches this level, the pump stops.	Green indicator light in on/off button flashes.
Warning (bottom)	Too low water level in borehole. Possible cause: Pumping in adjacent boreholes.	Alarm relay operates.
pH sensor on ground (pos. 33)		
Warning	The pH value is close to the maximum value allowed.	Alarm relay operates.
Alarm	The pH value has reached the maximum value allowed.	The pump stops. The indicator light "sensor alarm" is on.

- 1 SQE-NE pump
- 2 Cable
- 3 Cable clips
- 5 CU 300 control unit
- 11 Level sensor
- 21 Mains connection, 1 x 200-240 V, 50/60 Hz
- 22 Riser pipe
- 29 R100 remote control
- 30 Straining wire
- 31 Wire clamp
- 33 pH sensor

TM01 9397 1800

## Workshop setting of operating parameters

Using the R100 and the CU 300 enables change of the motor speed in a workshop and thereby setting of the pump to a specific performance.

A program called "SQE Speed Calculation" has been developed for the calculation of the speed in order to obtain the required flow rate and head.

## Dry-running protection

The  $P_{\text{cut-out}}$  value, ensuring dry-running protection is factory-set for the SQE-NE pump.

If the speed of the SQE-NE pump is reduced by more than  $1000 \text{ min}^{-1}$ , the  $P_{\text{cut-out}}$  value must be readjusted by means of the CU 300 and R100.

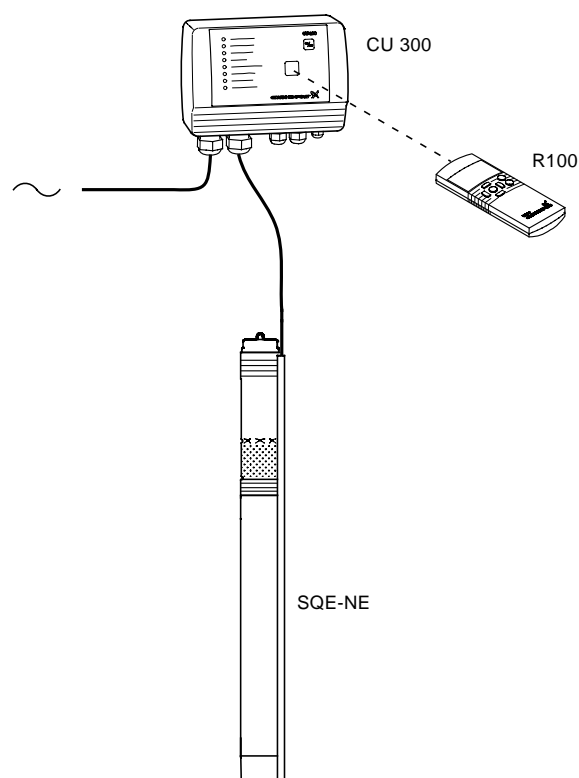

**Note:** The SQE-NE pump must not be started until the pump has been completely submerged below the water table.

However, the change of the motor speed can be made even if the pump is not running.

Fig. 20 Workshop setting of operating parameters

## Workshop setting of operating parameters

Part	Type	No. of units	Product number	Unit price	Total price
Pump	SQE-NE,				
Remote control	R100				
Control unit	CU 300				
"SQE Speed Calculation"					

TM01 8650 4801



## Communication

### CU 300 control unit

The CU 300 is a control and communication unit specially developed for the SQE-NE submersible pumps.

The CU 300 control unit provides

- easy adjustment to a specific borehole
- full control of the SQE-NE pumps
- two-way communication with the SQE-NE pumps
- alarm indication of pump operation by diodes on the front
- the possibility of starting, stopping and resetting the pump simply by means of a push-button.

The CU 300 communicates with the pump via the power supply cable. This is called mains-borne signalling or power line communication. Using this concept means that no extra cables between the CU 300 and the pump are required.

The following alarms can be indicated by the CU 300:

- No contact
- Overvoltage
- Undervoltage
- Dry running
- Speed reduction
- Overtemperature
- Overload
- Sensor alarm.

The CU 300 incorporates

- external signal input for two analog sensors and one digital sensor
- relay output for external alarm indication
- control according to the signals received, e.g. concerning flow, pressure, water level and conductivity.

Furthermore, the CU 300 offers the possibility of remote control.

### R100 remote control

Wireless infrared remote control of the CU 300 is possible with the R100.

With the R100 it is possible to monitor and change the operating parameters, see the R100 menu overview on page 26. The R100 is a strong tool in case fault finding is required.

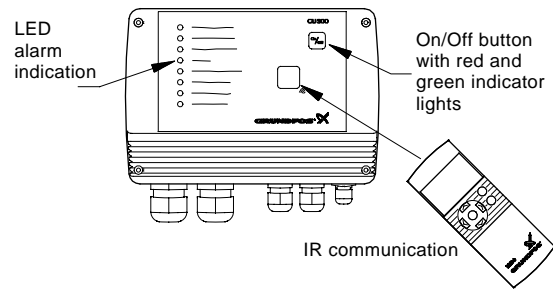

Fig. 21 CU 300 front

TM01 2760 4801

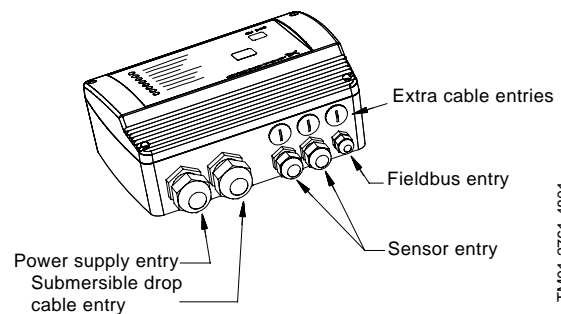

Fig. 22 CU 300 cable entries

TM01 2761 4801

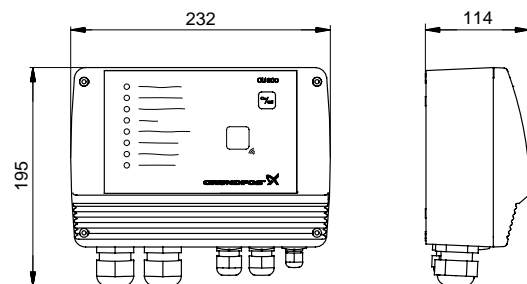
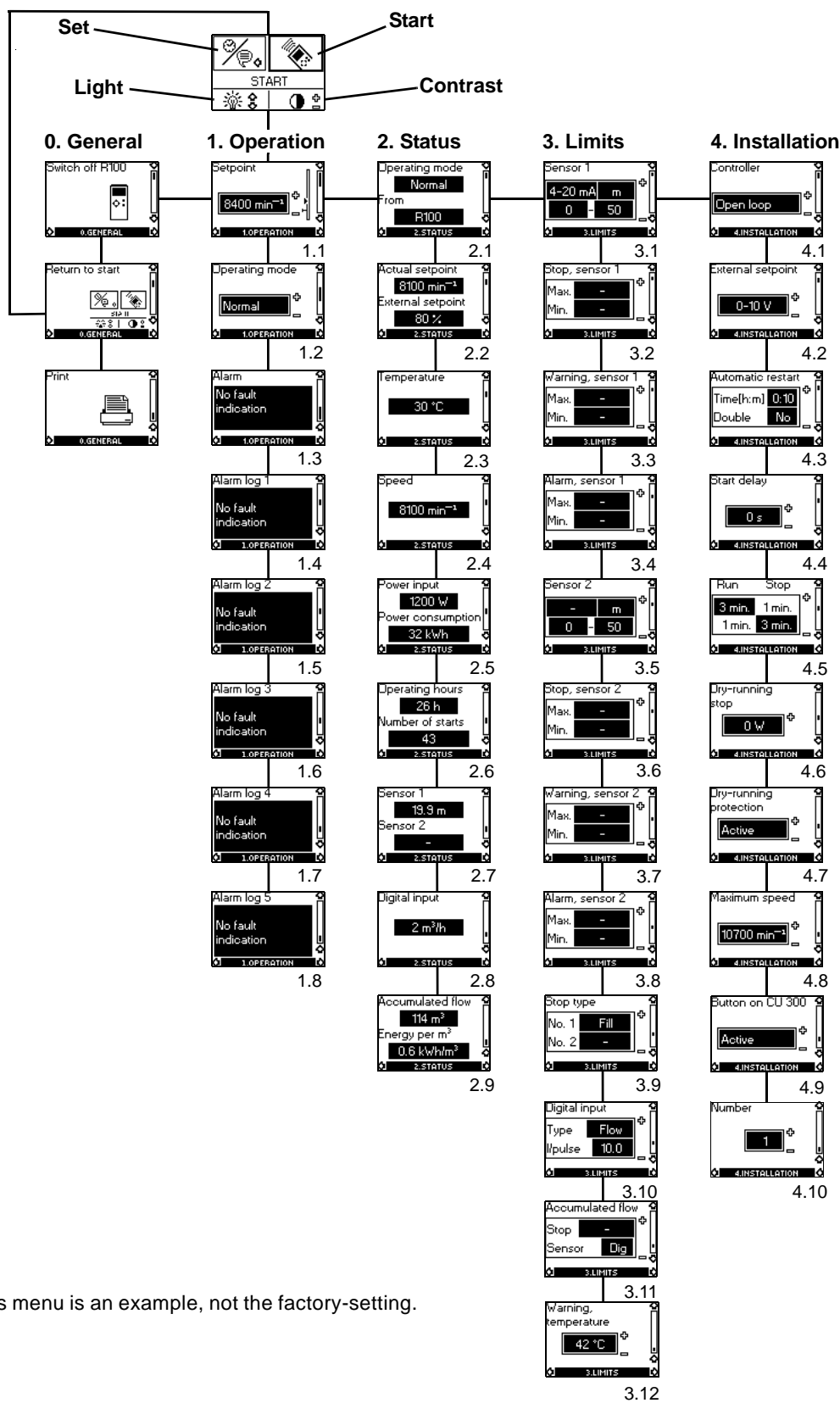

Fig. 23 CU 300 dimensions

Dimensions stated in mm.

TM01 2781 4601

## R100 menu overview for the CU 300



**Note:** This menu is an example, not the factory-setting.

Fig. 24 Menu overview

TM01 2675 0201

## R100 menus for CU 300

### 0. General

1. Operation
  - 1.1 Setpoint setting
  - 1.2 Selection of operating mode
  - 1.3 Alarm indication.

### 2. Status

The indication of:

- 2.1 Actual operating mode
- 2.2 Actual and external setpoint
- 2.3 Actual motor temperature
- 2.4 Actual motor speed
- 2.5 Actual power input and accumulated motor power consumption
- 2.6 Accumulated number of operating hours and accumulated number of starts
- 2.7 Actual values of sensors 1 and 2, respectively
- 2.8 Actual values of the digital input
- 2.9 Accumulated flow and the power used to pump 1 m<sup>3</sup>.

The R100 offers the possibility of making a number of settings:

### 3. Limits

The setting of:

- 3.1 Sensor 1 parameters
- 3.2 Min. and max. stop limits of sensor 1
- 3.3 Min. and max. warning limits of sensor 1
- 3.4 Min. and max. alarm limits of sensor 1
- 3.5 Sensor 2 parameters
- 3.6 Min. and max. stop limits of sensor 2
- 3.7 Min. and max. warning limits of sensor 2
- 3.8 Min. and max. alarm limits of sensor 2
- 3.9 Filling or emptying
- 3.10 Setting of the function of the digital sensor connected to the digital input
- 3.11 Setting of the water quantity stop limit and setting of the sensor to detect water quantity
- 3.12 Setting of the temperature warning limits of the motor electronics.

### 4. Installation

- 4.1 Selection of controller
- 4.2 Setting of external setpoint
- 4.3 Setting of automatic restart time
- 4.4 Allocation of individual start delays
- 4.5 Setting of the stop and run times for the dewatering function
- 4.6 Setting of the dry-running stop limit
- 4.7 Activation or deactivation of the dry-running protection
- 4.8 Setting of the maximum motor speed
- 4.9 Activation or deactivation of the On/Off button on the CU 300
- 4.10 Allocation of number where more than one CU 300 are installed.

## Examples of R100 displays

### Menu OPERATION

#### Setpoint setting

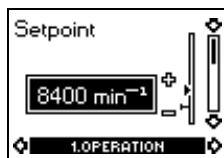

1.1

The pump is factory set to maximum speed, 10,700 min<sup>-1</sup>. The R100 makes it possible to reduce the pump speed by changing the setpoint. The speed can be set to 3,000 - 10,700 min<sup>-1</sup>, at intervals of 100 min<sup>-1</sup>.

The unit of the setpoint is automatically changed according to the unit of the sensor connected to sensor input 1.

**Example:** Sensor input 1 is connected to a pressure sensor using the unit metre (m) and the range 0-60. Consequently, the setpoint of display 1.1 can be set within the range between 0-60 m.

#### Menu STATUS

The displays appearing in this menu are status displays only. It is not possible to change settings in this menu.

#### Accumulated flow

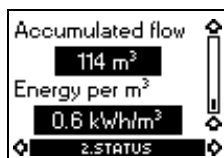

2.9

Display 2.9 shows the water quantity (in m<sup>3</sup>) pumped. The value shown is the accumulated flow registered by the sensor selected in display 3.11.

The power used to pump 1 m<sup>3</sup> is shown in the display as energy per m<sup>3</sup> (kWh/m<sup>3</sup>).

It is possible to read the status of the accumulated flow and energy per m<sup>3</sup> at any time.

#### Accumulated number of operating hours and number of starts



2.6

The value of operating hours and the number of starts are values accumulated from the time of installation, and they cannot be reset.

Both values are stored in the motor electronics, and they are kept even if the CU 300 is replaced.

The number of operating hours is registered every two minutes of continuous operation.

#### Menu LIMITS

##### Sensor 1

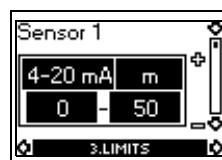

3.1

The setting of sensor 1.

Depending on the type of sensor, the following settings can be made:

- Sensor output:  
– (not active), 0-10 V, 2-10 V, 0-20 mA, 4-20 mA.
- Setting range unit:  
m<sup>3</sup>/h, m, %, GPM, ft.
- Sensor minimum value: 0-249 (0, 1, 2, 3.....249).
- Sensor maximum value: 1-250 (1, 2, 3, 4.....250).

## Alarm indication

The CU 300 offers the following alarm indications.

Alarm	Description	The pump will be restarted automatically
No contact	No contact/communication between the CU 300 and the SQE-NE pump. <b>Note:</b> This alarm does not affect pump operation.	–
Overvoltage	The supply voltage exceeds the limit value.	when the voltage is within the specified range.
Undervoltage	The supply voltage is below the limit value.	when the voltage is within the specified range.
Dry running	The dry-running protection of the pump has been activated.	after 5 minutes (default), or a period set with the R100.
Speed reduction	The motor speed is reduced. <b>Note:</b> The speed is resumed when the cause has been remedied or has disappeared.	–
Overtemperature	The motor temperature exceeds the limit value.	when the motor electronics has cooled sufficiently.
Overload	The current consumption of the motor exceeds the value set.	after 5 minutes (default), or a period set with the R100.
Sensor alarm	Sensor alarm may be caused by the following: The measured value has dropped outside the measuring range set. The sensor is defective. The sensor output setting made via the R100 is incorrect.	after 5 minutes (default), or a period with the R100.

## Benefits of CU 300/R100

Alarm	Description	The following items are no longer required
No contact	Provides knowledge of contact between the SQE-NE pump and the CU 300.	–
Overvoltage	The supply voltage is measured.	Overvoltage relay.
Undervoltage	The supply voltage is measured.	Undervoltage relay.
Dry running	Provides dry-running protection of the pump.	Level relay, electrodes, cables.
Speed reduction	Ensures pump operation at a moderate undervoltage and overload, thereby ensuring that the motor is not overloaded.	Urgent need for service.
Overtemperature	The pump is stopped at a critical temperature. Once the motor electronics has cooled sufficiently, the motor will restart – automatically.	–
Overload	Provides overload protection of the motor.	Motor starter.
Sensor alarm	Sensors can be connected directly to the CU 300. The sensor signals are monitored.	External control unit.

### Pump selection

#### Determining head and flow

Pump selection should be based on the required flow and head.

#### 1. Flow

Selection of the most suitable pump size should be based on the likely maximum flow of liquid expected to be pumped.

#### 2. Head

H [m]	=	$P_{\text{outlet}} \times 10.2 + H_{\text{geo}} + H_f$
$P_{\text{outlet}}$	=	Required pressure at the outlet
$H_{\text{geo}}$	=	Difference in height between the lowest water level and the pump outlet
$H_f$	=	Friction loss in pipes and tubes. See table below.

#### Calculation example

Required flow: 3.8 m<sup>3</sup>/h

$P_{\text{outlet}} = 3$  bar

$H_{\text{geo}} = 25$  m

The plastic pipes have a diameter of Ø32 and a length of 25 m.

This will give:

$H_f = \text{Value from table}/100 \times \text{length of pipe}$

$H_f = 18/100 \times 25 \text{ m} = 4.5 \text{ m}$

$H [\text{m}] = P_{\text{outlet}} \times 10.2 + H_{\text{geo}} + H_f$

$= 3 \times 10.2 + 25 \text{ m} + 4.5 \text{ m} = 60.1 \text{ m}$

**Selected at Q = 3.8 m<sup>3</sup>/h, H = 60.1 m**

For selection of the optimum pump type, see the next page.

#### Examples of head losses in plastic pipes and ordinary water pipes: $H_f$

**Note:** The material of the riser pipe must be selected according to the pumped liquid.

Upper figures indicate the water velocity in m/sec.

Lower figures indicate head loss in metres per 100 metres of straight pipes.

Volume of water			Plastic pipes* (PELM/PEH PN 10 PELM)				Ordinary water pipes**				
m <sup>3</sup> /h	Litres/min.	Litres/sec.	Nominal pipe diameter in inches and internal diameter in [mm]								
			25 20.4	32 26.2	40 32.6	50 40.8	1/2" 15.75	3/4" 21.25	1" 27.00	1 1/4" 35.75	1 1/2" 41.25
0.6	10	0.16	0.49	0.30	0.19	0.12	0.855	0.470	0.292		
			1.8	0.66	0.27	0.085	9.910	2.407	0.784		
0.9	15	0.25	0.76	0.46	0.3	0.19	1.282	0.705	0.438	0.249	
			4.0	1.14	0.6	0.18	20.11	4.862	1.570	0.416	
1.2	20	0.33	1.0	0.61	0.39	0.25	1.710	0.940	0.584	0.331	0.249
			6.4	2.2	0.9	0.28	33.53	8.035	2.588	0.677	0.346
1.5	25	0.42	1.3	0.78	0.5	0.32	2.138	1.174	0.730	0.415	0.312
			10.0	3.5	1.4	0.43	49.93	11.91	3.834	1.004	0.510
1.8	30	0.50	1.53	0.93	0.6	0.38	2.565	1.409	0.876	0.498	0.374
			13.0	4.6	1.9	0.57	69.34	16.50	5.277	1.379	0.700
2.1	35	0.58	1.77	1.08	0.69	0.44	2.993	1.644	1.022	0.581	0.436
			16.0	6.0	2.0	0.70	91.54	21.75	6.949	1.811	0.914
2.4	40	0.67	2.05	1.24	0.80	0.51		1.879	1.168	0.664	0.499
			22.0	7.5	3.3	0.93		27.66	8.820	2.290	1.160
3.0	50	0.83	2.54	1.54	0.99	0.63		2.349	1.460	0.830	0.623
			37.0	11.0	4.8	1.40		41.40	13.14	3.403	1.719
3.6	60	1.00	3.06	1.85	1.2	0.76		2.819	1.751	0.996	0.748
			43.0	15.0	6.5	1.90		57.74	18.28	4.718	2.375
4.2	70	1.12	3.43	2.08	1.34	0.86		3.288	2.043	1.162	0.873
			50.0	18.0	8.0	2.50		76.49	24.18	6.231	3.132
4.8	80	1.33		2.47	1.59	1.02			2.335	1.328	0.997
				25.0	10.5	3.00			30.87	7.940	3.988
5.4	90	1.50		2.78	1.8	1.15			2.627	1.494	1.122
				30.0	12.0	3.50			38.30	9.828	4.927
6.0	100	1.67		3.1	2.0	1.28			2.919	1.660	1.247
				39.0	16.0	4.6			46.49	11.90	5.972
7.5	125	2.08		3.86	2.49	1.59			3.649	2.075	1.558
				50.0	24.0	6.6			70.41	17.93	8.967
9.0	150	2.50			3.00	1.91				2.490	1.870
					33.0	8.6				25.11	12.53
10.5	175	2.92			3.5	2.23				2.904	2.182
					38.0	11.0				33.32	16.66
90 ° bends, slide valves							1.0	1.0	1.1	1.2	1.3
T-pieces, non-return valves							4.0	4.0	4.0	5.0	5.0

\* The table is based on a monogram.  
Roughness: K = 0.01 mm.  
Water temperature: t = 10 °C.

\*\* The data are calculated in accordance with H. Lang's new formula, a = 0.02 and on the basis of a water temperature of 10 °C. The head loss in bends, slide valves, T-pieces and non-return valves is equivalent to the metres of straight pipes stated in the last two lines of the table.

## Pump sizing

**Important:** The dry-running protection is effective only within the recommended pump duty range, i.e. the bold curves, see the performance curves.

Pump type	Power [kW]	Flow rate Q [m <sup>3</sup> /h] / [l/s]												Max. head [m] (Q = 0 m <sup>3</sup> /h)	Rated current I <sub>1/1</sub> [A]		Pipe connection Rp	Length [mm]	
		0.5/	1.0/	1.5/	2.0/	2.5/	3.0/	3.5/	4.0/	5.0/	6.0/	7.0/	8.0/		9.0/	230 V			200 V
		0.14	0.28	0.42	0.56	0.70	0.83	0.97	1.11	1.39	1.67	1.95	2.22		2.50				
		Head [m]																	
SQE 2-35 NE	0.4	39	37	35	31	26	19	-	-	-	-	-	-	-	41	3.0	3.5	1 1/4	747
SQE 2-50 NE	0.6	58	56	52	47	38	26	-	-	-	-	-	-	-	59	4.1	5.0	1 1/4	747
SQE 2-65 NE	0.8	76	73	68	60	49	34	-	-	-	-	-	-	-	78	5.3	6.2	1 1/4	774
SQE 2-75 NE	1.0	94	89	83	74	60	42	-	-	-	-	-	-	-	97	6.5	7.5	1 1/4	828
SQE 2-90 NE	1.2	111	106	98	87	71	50	-	-	-	-	-	-	-	116	7.6	9.1	1 1/4	864
SQE 2-105 NE	1.4	129	123	113	100	82	58	-	-	-	-	-	-	-	135	8.7	10.4	1 1/4	891
SQE 2-115 NE	1.6	147	139	128	114	94	66	-	-	-	-	-	-	-	153	9.9	11.8	1 1/4	945
SQE 5-15 NE	0.27	-	-	-	-	14	13	13	11	8	-	-	-	-	16	2.3	2.7	1 1/2	747
SQE 5-25 NE	0.54	-	-	-	-	28	27	25	22	17	-	-	-	-	31	3.8	4.6	1 1/2	747
SQE 5-35 NE	0.81	-	-	-	-	41	39	37	32	24	-	-	-	-	46	5.4	6.2	1 1/2	864
SQE 5-45 NE	1.08	-	-	-	-	54	52	49	42	32	-	-	-	-	61	6.9	8.7	1 1/2	864
<b>SQE 5- 55 NE</b>	<b>1.35</b>	-	-	-	-	67	64	<b>61</b>	52	40	-	-	-	-	<b>76</b>	<b>8.4</b>	<b>10.0</b>	<b>1 1/2</b>	<b>945</b>
SQE 5-65 NE	1.62	-	-	-	-	80	77	73	62	47	-	-	-	-	90	9.9	11.8	1 1/2	945

Diameter of SQE-NE pumps: 74 mm

### Example:

**Required:** Flow rate: 3.8 m<sup>3</sup>/h => nearest higher value in table is 4.0 m<sup>3</sup>/h.

Head: 60.1 m => nearest higher value in table is 61 m.

**Selected:** Pump type: SQE 5-55 NE (as it offers the best pump efficiency for the required flow and head).

Required pump power input: 1.35 kW.

Rated current: I<sub>1/1</sub> = 8.4 A at 230 V.

I<sub>1/1</sub> = 10.0 A at 200 V.

Pipe connection: Rp 1 1/2.

Length: 945 mm.

## Variable speed

The performance of the SQE-NE pump can be adjusted to a specific duty point within its performance range. This is done by means of CU 300 and R100.

As energy savings can be achieved by reducing the speed to the required performance, the SQE-NE pump is ideally suited to applications where the water consumption varies over time and when the duty point is between two pump curves. The curve chart below shows the performance of a SQE 5-55 NE pump at various speeds.

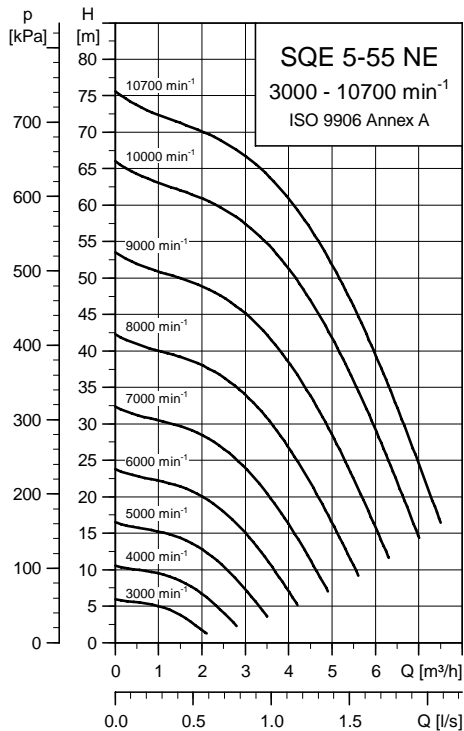

Fig. 25 Variable-speed curves

### Example: How to select an SQE-NE pump

- A head of 60.1 m and a flow of 3.8 m<sup>3</sup>/h are required.
- The optimum pump size is SQE 3-NE. In the curve chart to the right, draw a rightward, horizontal line from the head required 60.1 m (1) to the intersection with the vertical line from the required flow (2). In this example, the intersection point (3) of the two lines is not on one of the pump curves, therefore follow the pipe characteristic upwards. The intersection point of the pump curve and the pipe characteristic (4) gives the size of the pump. The size of the pump is SQE 5-55 NE.
- The pump power input per stage (P<sub>2</sub>) can be read to be 0.26 kW (5), and the pump efficiency is 55 % (6) per stage.
- The SQE 5-55 NE has 5 stages, see page 37. With 5 stages, the total pump power input for the SQE 5-55 NE is 1.3 kW (0.26 kW x 5) which means a 1.1 - 1.73 kW MSE 3-NE motor.

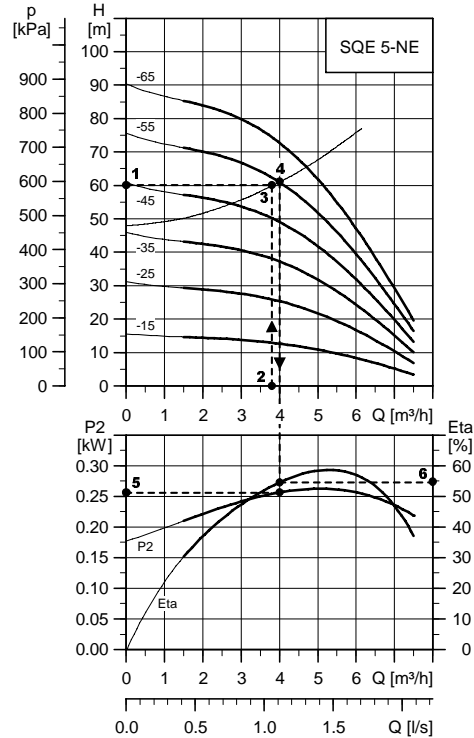

Fig. 26 Selecting the right pump

## Curve conditions

The guidelines below apply to the performance curves on pages 34 to 36:

### General

- Curve tolerances are according to ISO 9906, Annex A, i.e. all curves show mean values.
- None of the curves must be used as guarantee curves.
- The **bold** curves show the **recommended** duty range.
- The measurements have been made with airless water at a temperature of 20 °C.
- The conversion between head H (m) and pressure p (kPa) applies to water with a density of 1,000 kg/m<sup>3</sup>.
- The curves apply to a kinematic viscosity of 1 mm<sup>2</sup>/s (1 cSt). If the pump is used for liquids with a viscosity higher than that of water, this will reduce the head and increase the power consumption.
- **Q/H:** The curves are inclusive of valve and inlet losses at the actual speed. Operation without non-return valve will increase the actual head at nominal performance by 0.5 to 1.0 m.
- **Power curve:** P<sub>2</sub> curve shows the pump power input at the actual speed of each individual pump size.
- **Efficiency curve:** The eta curve shows the pump efficiency per stage.





# Performance curves

Submersible pumps  
SQE 2-NE

## SQE 2-NE

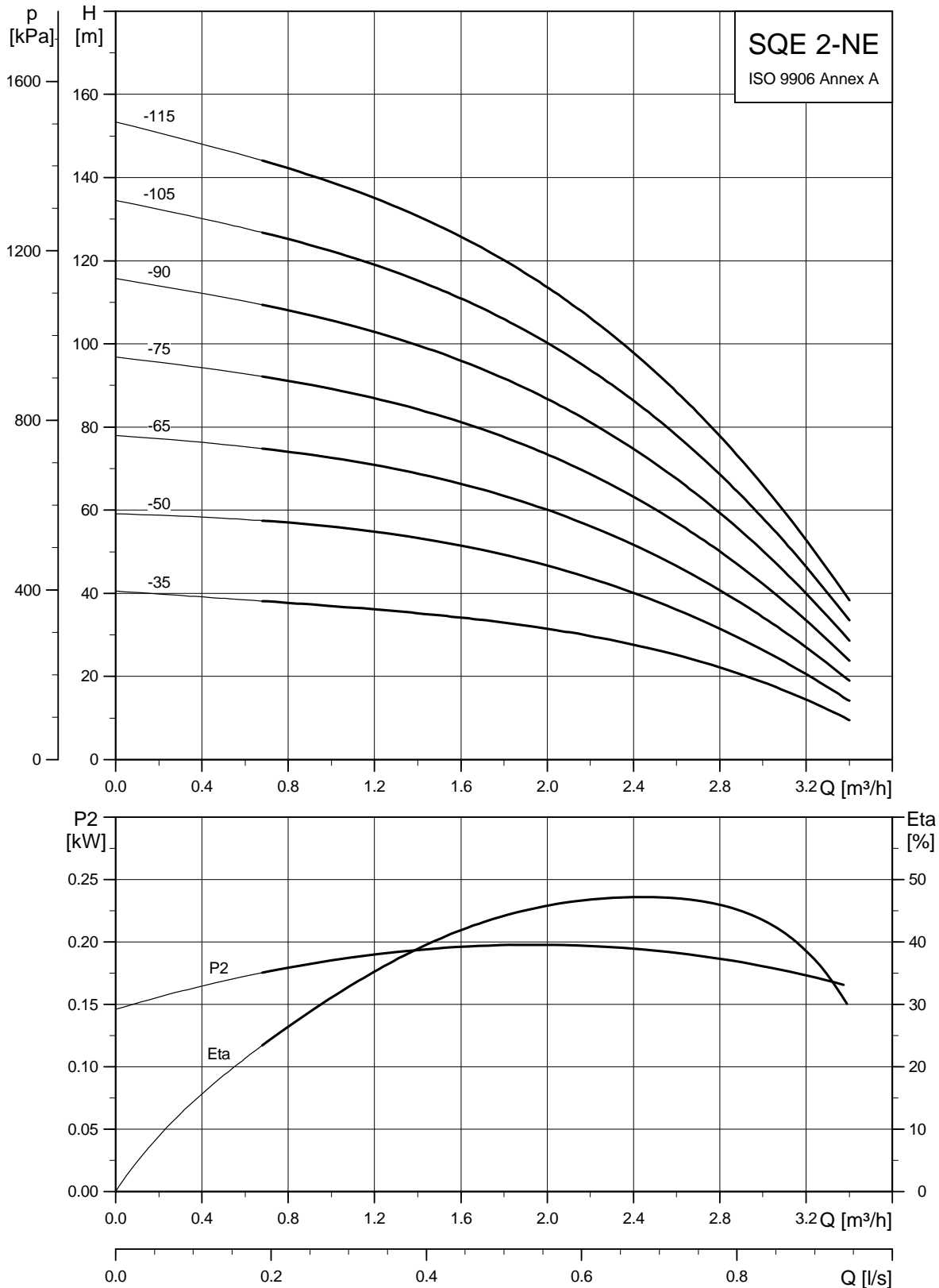

TM01 7399 2500

### Dimensions and weights

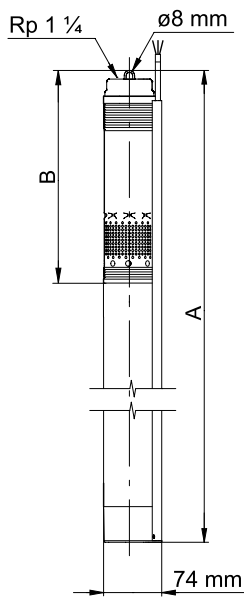

TM01 2752 0499

Pump type	Number of stages	Motor		Dimensions [mm]		Net weight [kg]★	Shipping volume [m <sup>3</sup> ]★
		Type	Output power (P <sub>2</sub> ) [kW]	A	B		
SQE 2-35 NE	2	MSE 3-NE	0.1 - 0.63	744	268	4.7	0.0092
SQE 2-50 NE	3	MSE 3-NE	0.1 - 0.63	744	268	4.8	0.0092
SQE 2-65 NE	4	MSE 3-NE	0.7 - 1.05	771	295	5.4	0.0094
SQE 2-75 NE	5	MSE 3-NE	0.7 - 1.05	825	349	5.5	0.0100
SQE 2-90 NE	6	MSE 3-NE	1.1 - 1.73	825	349	6.2	0.0104
SQE 2-105 NE	7	MSE 3-NE	1.1 - 1.73	888	376	6.3	0.0107
SQE 2-115 NE	8	MSE 3-NE	1.1 - 1.73	942	430	6.4	0.0113

★ including pump, motor and cable guard.

### Electrical data

1 x 200-240 V, 50/60 Hz

Pump type	Motor type	Input power, motor (P <sub>1</sub> ) [kW]	Output power, motor (P <sub>2</sub> ) [kW]	Required input power, pump [kW]	Rated current I <sub>1/1</sub> [A]		Rated motor efficiency (η) [%]
					230 V	200 V	
SQE 2-35 NE	MSE 3-NE	0.69	0.70	0.46	3.0	3.5	70
SQE 2-50 NE	MSE 3-NE	0.97	0.70	0.66	4.1	5.0	70
SQE 2-65 NE	MSE 3-NE	1.22	1.15	0.87	5.3	6.2	73
SQE 2-75 NE	MSE 3-NE	1.48	1.15	1.07	6.5	7.5	73
SQE 2-90 NE	MSE 3-NE	1.77	1.68	1.28	7.6	9.1	74
SQE 2-105 NE	MSE 3-NE	2.04	1.68	1.48	8.7	10.4	74
SQE 2-115 NE	MSE 3-NE	2.30	1.68	1.69	9.9	11.8	74

# Performance range

Submersible pumps  
SQE 5-NE

## SQE 5-NE

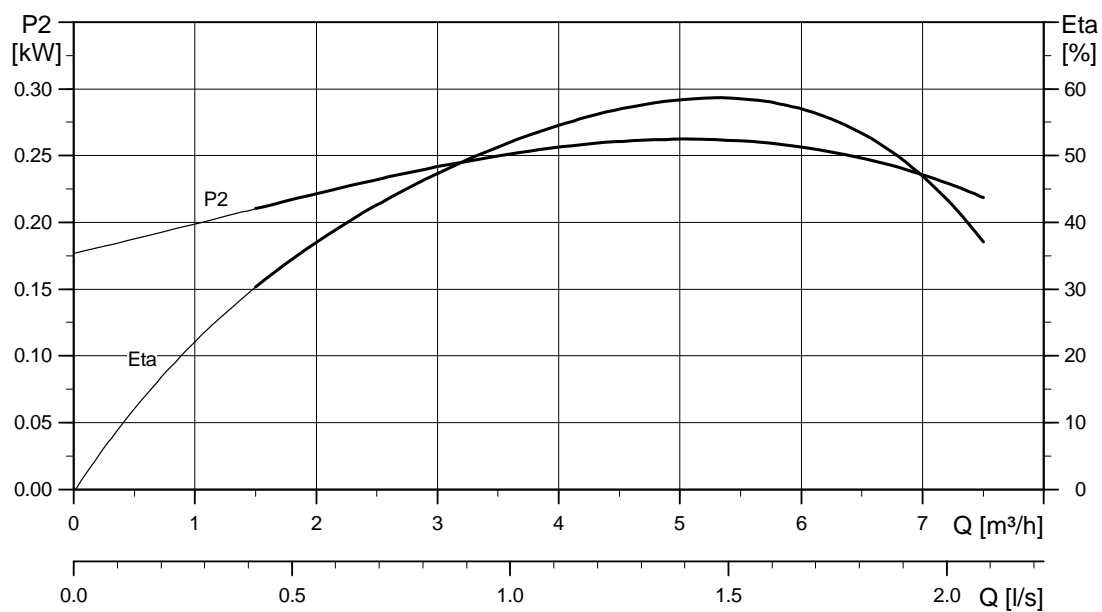
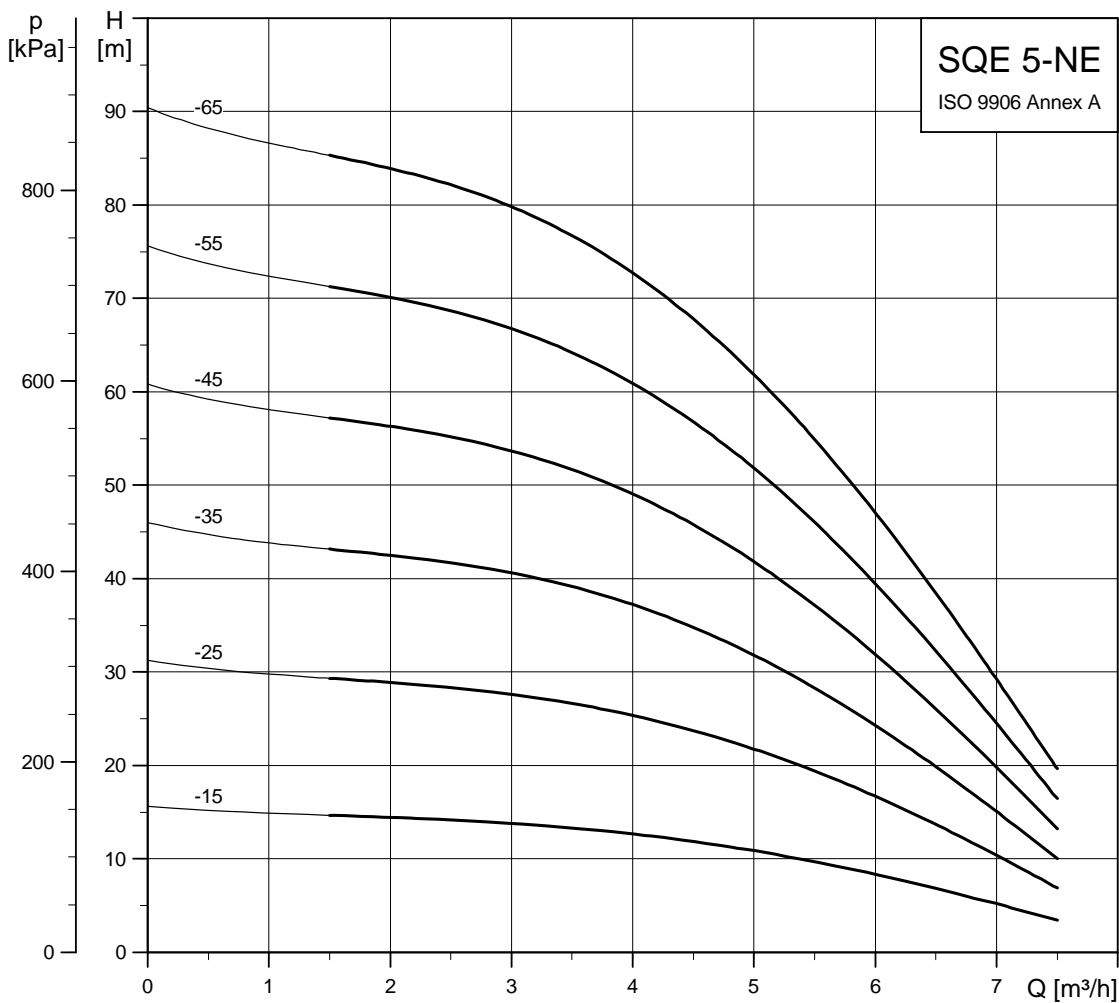

TM01 7401 2500

### Dimensions and weights

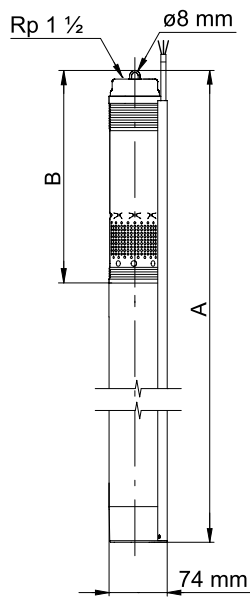

Pump type	Number of stages	Motor		Dimensions [mm]		Net weight [kg]★	Shipping volume [m <sup>3</sup> ]★
		Type	Output power (P <sub>2</sub> ) [kW]	A	B		
SQE 5-15 NE	1	MSE 3-NE	0.1 - 0.63	744	268	4.7	0.0100
SQE 5-25 NE	2	MSE 3-NE	0.1 - 0.63	744	268	4.8	0.0100
SQE 5-35 NE	3	MSE 3-NE	0.1 - 0.63	825	295	5.5	0.0113
SQE 5-45 NE	4	MSE 3-NE	0.7 - 1.05	825	349	5.5	0.0113
SQE 5-55 NE	5	MSE 3-NE	1.1 - 1.73	942	430	6.4	0.0092
SQE 5-65 NE	6	MSE 3-NE	1.1 - 1.73	942	430	6.4	0.0092

★ including pump, motor and cable guard.

### Electrical data

1 x 200-240 V, 50/60 Hz

Pump type	Motor type	Input power, motor (P <sub>2</sub> ) [kW]	Output power, motor (P <sub>2</sub> ) [kW]	Required input power, pump [kW]	Rated current I <sub>1/1</sub> [A]		Rated motor efficiency (η) [%]
					230 V	200 V	
SQE 5-15 NE	MSE 3-NE	0.54	0.70	0.34	2.3	2.7	70
SQE 5-25 NE	MSE 3-NE	0.89	0.70	0.61	3.8	4.6	70
SQE 5-35 NE	MSE 3-NE	1.23	1.15	0.88	5.4	6.2	70
SQE 5-45 NE	MSE 3-NE	1.58	1.15	1.15	6.9	8.7	73
SQE 5-55 NE	MSE 3-NE	1.95	1.68	1.42	8.4	10.0	74
SQE 5-65 NE	MSE 3-NE	2.30	1.68	1.69	9.9	11.8	74

## Technical data

### SQE-NE pump

<b>Mains supply to pump</b>	1 x 200-240 V – 10 %/+ 6 %, 50/60 Hz, PE.
<b>Starting</b>	Soft starting.
<b>Stopping</b>	Soft stopping when stopped via the CU 300.
<b>Run-up time</b>	Maximum: 3 seconds. No limitation to the number of starts/stops per hour.
<b>Motor protection</b>	Built into the pump. Protection against: <b>Dry running</b> <b>Overvoltage and undervoltage</b> ; the motor cuts out below 150 V and above 280 V <b>Overload</b> <b>Overtemperature</b>
<b>Sound pressure level</b>	The sound pressure level is lower than the limiting values stated in the EEC Machinery Directive.
<b>Radio noise</b>	The SQE-NE complies with the EMC Directive 89/336/EEC. Standards: EN 50081-1 and 50082-2.
<b>Reset function</b>	SQE-NE pumps can be reset via the CU 300 (possibly with the R100).
<b>Power factor</b>	PF = 1.
<b>Operation via generator</b>	It is recommended that the generator output is equal to the motor input power $P_1$ [kW] plus 50 %; min. $P_1 + 10$ %, however.
<b>Earth-leakage circuit breaker</b>	If the pump is connected to an electric installation where an earth-leakage circuit breaker (ELCB) is used as an additional protection, this circuit breaker must trip out when earth fault currents with pulsating DC content occur.
<b>Pipe connection</b>	SQE 2-NE: Rp 1 1/4. SQE 5-NE: Rp 1 1/2.
<b>Borehole diameter</b>	Minimum: 76 mm.
<b>Installation depth</b>	Maximum: 150 m below static water table (15 bar). For horizontal installation, a flow sleeve is recommended. Installation depth below dynamic water level: Vertical installation with/without flow sleeve: 0.5 m. Horizontal installation with/without flow sleeve: 0.5 m.
<b>NPSH</b>	Maximum 8 m.
<b>Strainer</b>	Holes in the strainer: $\varnothing 2.3$ mm.
<b>Liquid temperature</b>	30 °C: Flow velocity past the motor, 0.0 m/s (free convection). 40 °C: Flow velocity past the motor, min. 0.15 m/s.
<b>Pumped liquids</b>	pH: 2 to 13. Sand content: Maximum 50 g/m <sup>3</sup> . A larger sand content will considerably reduce the life of service parts.

### CU 300 control unit

<b>Supply voltage</b>	1 x 200-240 V –10 %/+6 %, 50/60 Hz, PE
<b>Power consumption</b>	5 W
<b>Current consumption</b>	Maximum 130 mA
<b>Enclosure class</b>	IP 55
<b>Ambient temperature</b>	In operation: –30 °C to +50 °C In store: –30 °C to +60 °C
<b>Relative air humidity</b>	Maximum: 95 %
<b>Pump cable</b>	Maximum cable length between CU 300 and pump: 200 m
<b>Back-up fuse</b>	Maximum: 16 A
<b>Radio noise</b>	The CU 300 complies with the EMC Directive 89/336/EEC. Standards: EN 55 014 and 55014-2.
<b>Marking</b>	CE
<b>Sensor input</b>	0-20 mA 4-20 mA 0-10 VDC 2-10 VDC
<b>Load</b>	Maximum: 100 mA

## Material specification (pump)

Pos.	Component	Material	DIN W.-Nr.	AISI
1	Valve casing	PVDF CN-F		
1a	Discharge chamber	Stainless steel	1.4401	316
1d	O-ring	FKM		
4	Top chamber	PVDF CN-F		
6	Top bearing	FKM		
7	Neck ring	PVDF CN-F		
7a	Lock ring	Stainless steel	1.4401	316
8	Bearing	Ceramics		
10	Bottom chamber	PVDF CN-F		
13	Impeller with tungsten-carbide bearing	PVDF CN-F		
14	Suction interconnector	PVDF CN-F		
16	Shaft with coupling	Stainless steel Sintered steel	1.4401	316
18	Cable guard	Stainless steel	1.4401	316
18a 18b	Screws for cable guard	Stainless steel	1.4401	316
32	Guide vanes	PVDF CN-F		
30	Cone for pressure equalisation	PVDF CN-F		
55	Pump sleeve	Stainless steel	1.4401	316
75	Priming screw	PVDF CN-F		
86	Lip seal	FKM rubber		

## Material specification (motor)

Pos.	Component	Material	DIN W.-Nr.	AISI
201	Stator	Stainless steel	1.4401	316
202	Rotor	Stainless steel	1.4401	316
202a	Stop ring	PP		
202b	Filter	Polyester		
203	Thrust bearing	Carbon		
205	Radial bearing	Ceramics/ tungsten carbide		
222a	Filling plug	FKM		
223	Electronic unit			
224	O-ring	FKM		
225	Top cover	PPS		
232	Shaft seal	FKM		
250	Nut (M4)	Stainless steel	1.4401	316
	Motor liquid	SML-2		

## Material specification (cable)

Pos.	Component	Material	DIN W.-Nr.	AISI
1	Rubber plug	FKM		
2	Plate	Stainless steel	1.4401	316
3	Filling compound	Polyurethane		
4	Housing	PVDF CN-F		
5	Cable	ETFE		
	4 nuts (M4)	Stainless steel	1.4401	316

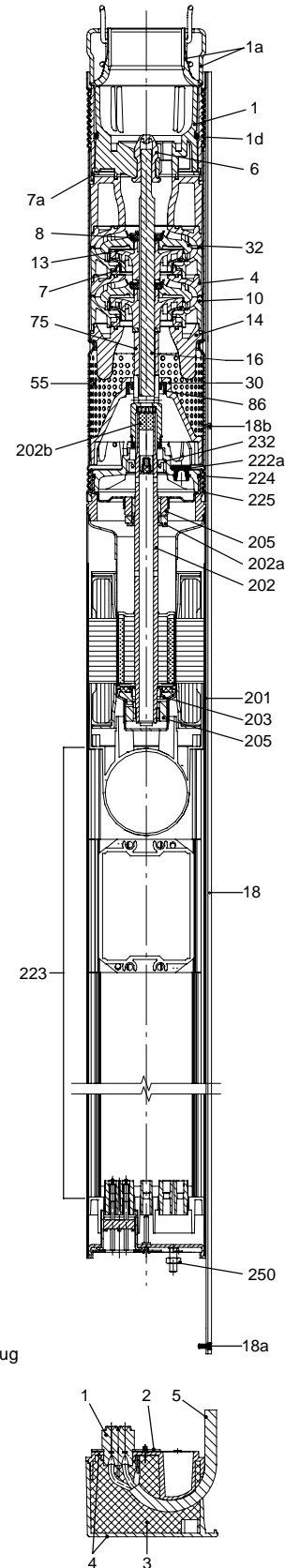

Cable with plug

Fig. 27 SQE-NE

TM01 9171 1300

## Wiring diagrams

### Mains connection of pump via pressure switch

The motor incorporates a starter device and may therefore be connected directly to the mains supply. The pump will typically be started and stopped via a pressure switch.

**Note:** The pressure switch must be sized for the maximum current of the specific pump type.

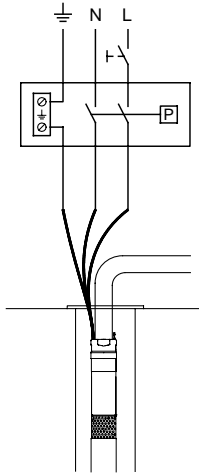

TM01 1480 4697

Fig. 28 Wiring diagram

### Electrical connection of CU 300

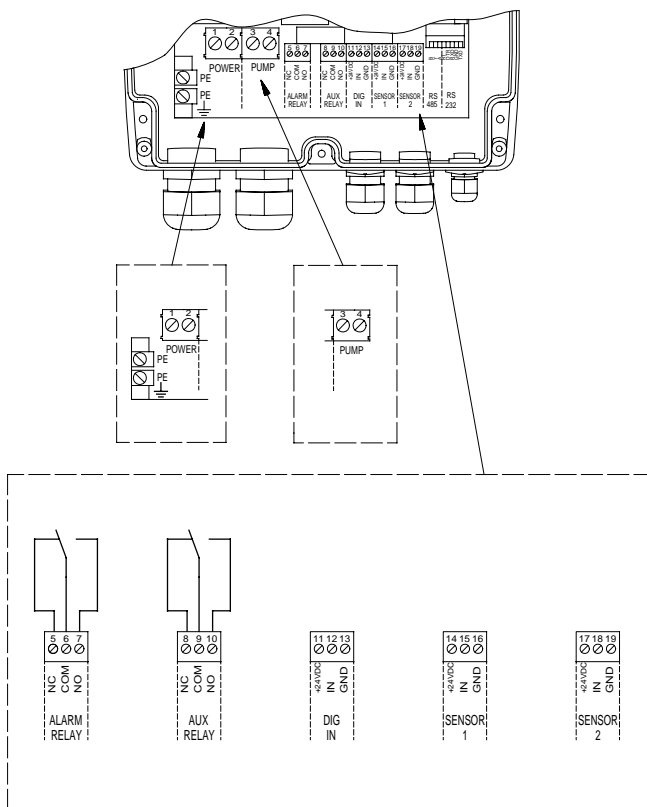

Fig. 29 Electrical connection of CU 300

#### Alarm relay:

Potential-free changeover contact.  
Maximum contact load: AC 250 V. Maximum current 1 A.  
Minimum contact load: DC 5 V, 10 mA.

#### Auxiliary relay:

Potential-free changeover contact.  
Maximum contact load: Safety extra-low voltage to be used only.  
Maximum current 1 A.  
Minimum contact load: DC 5 V, 10 mA.

#### Digital input:

External potential-free contact.  
Logic "0":  $U_{in} > 3.2$  V.  
Logic "1":  $U_{in} < 0.9$  V.

#### Sensor 1:

Voltage signal: DC 0-10 V/2-10 V,  $R_i = 11$  k $\Omega$   
Tolerance:  $\pm 3$  % at maximum voltage signal.  
Screened cable recommended, maximum length of cable: 500 m.  
Current signal: DC 0-20 mA/4 - 20 mA,  $R_i = 500$   $\Omega$   
Tolerance:  $\pm 3$  % at maximum current signal.  
Screened cable recommended, maximum length of cable: 500 m.

#### Sensor 2:

Potentiometer: DC 0-24 V, 10 k $\Omega$  (via internal voltage supply).  
Screened cable is recommended, maximum length of cable: 100 m.  
Voltage signal: DC 0-10 V/2-10 V,  $R_i = 11$  k $\Omega$   
Tolerance:  $\pm 3$  % at maximum voltage signal.  
Screened cable recommended, maximum length of cable: 500 m.  
Current signal: DC 0-20 mA/4-20 mA,  $R_i = 500$   $\Omega$   
Tolerance:  $\pm 3$  % at maximum current signal.  
Screened cable recommended, maximum length of cable: 500 m.

TM01 3008 2898



## Accessories

### Straining wire



TM00 7897 2296

Description	Version	Product number
Stainless steel DIN W.-Nr. 1.4401. Secures the submersible pump during installation. When ordering please state length [mm].	Diameter: 2 mm Admissible load: 100 kg	ID8957

### Wire clamp



TM00 7898 2296

Description	Version	Product number
Stainless steel DIN W.-Nr. 1.4401.	Two clamps per loop	ID8960

### CU 300, control unit

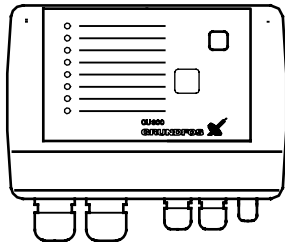

TM01 4356 0199

Description	Product number
CU 300 control unit provides full control of the SQE-NE pump. Language specific CU 300 versions available on request.	96422775 (English)

### R100 remote control

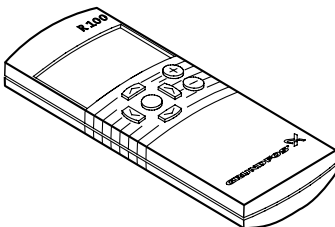

TM00 8367 4801

Description	Product number
The R100 is used for wireless communication with CU 300. Communication takes place by means of infrared light.	96615297

## Potentiometer

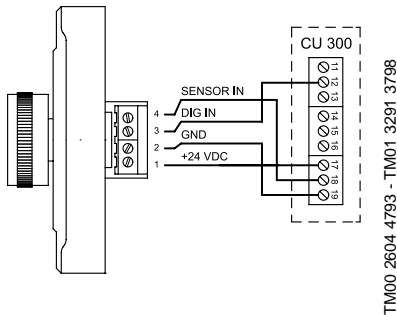
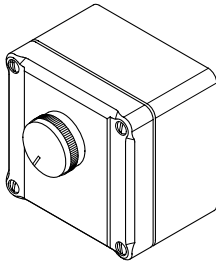

Description	Version	Product number
External potentiometer with cabinet for wall mounting. Screened cables, 4-wire cable. Max. length of cable: 100 m	Grundfos potentiometer, SPP1. Enclosure class: IP 55	625468

## SQE Speed calculation program

Type	Description	Product number
PC Tool "SQE Speed Calculation"	<ul style="list-style-type: none"> <li>• SQE speed calculation program (Windows 95) CD-ROM</li> <li>• Operating manual</li> </ul>	96478266

## Sensors

Sensors	Supplier	Type	Measuring range	Product number
Level sensor, including 30 m cable ★	JUMO	4390-242	0 - 2.5 bar	96037489
Level sensor, including 65 m cable ★	JUMO	4390-242	0 - 6 bar	96037490
Level sensor, including 105 m cable ★	JUMO	4390-242	0 - 10 bar	96037491
Pressure switch	Condor	mdr 21/6	1 - 6 bar	ID6462
Flow switch unit (SQE 2)	Grundfos	mdr 21/6 1"	0 - 5 m <sup>3</sup> /h	96037332
Flow switch unit (SQE 5)	Grundfos	FS 200	5 - 7 m <sup>3</sup> /h	96037559
Flow meter (pulsating) 1 l/pulse	Bdr. Dahl	QN 2.5	0 - 5 m <sup>3</sup> /h	96037492
Flow meter (pulsating) 2.5 l/pulse	Bdr. Dahl	QN 6	0 - 12 m <sup>3</sup> /h	96037583
Flow meter (pulsating) 5 l/pulse	Bdr. Dahl	QN 10	0 - 20 m <sup>3</sup> /h	96037584
Pressure sensor kit for CU 300 incl. 2 m cable	Danfoss	MBS 3000	0 - 4 bar	405160
Pressure sensor kit for CU 301 incl. 2 m cable	Grundfos	Grundfos type	0 - 6 bar	405161
			0 - 6 bar	96437851

★ Made of PE, the cable is only suitable for short time use in pumped liquids containing organic solvents.

## Order data

### Product numbers

The pump is supplied complete with motor and cable guard fitted, but without the cable with plug, which must be ordered separately.

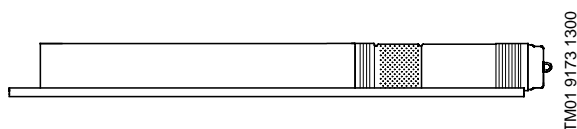

Fig. 30 SQE-NE

### SQE 2-NE

Pump type	Motor		Product number
	Type	P <sub>2</sub> [kW]	
SQE 2-35 NE	MSE 3-NE	0.70	96160709
SQE 2-50 NE	MSE 3-NE	0.70	96160710
SQE 2-65 NE	MSE 3-NE	1.15	96160711
SQE 2-75 NE	MSE 3-NE	1.15	96160712
SQE 2-90 NE	MSE 3-NE	1.68	96160713
SQE 2-105 NE	MSE 3-NE	1.68	96160714
SQE 2-115 NE	MSE 3-NE	1.68	96160715

### SQE 5-NE

Pump type	Motor		Product number
	Type	P <sub>2</sub> [kW]	
SQE 5-15 NE	MSE 3-NE	0.70	96160723
SQE 5-25 NE	MSE 3-NE	0.70	96160724
SQE 5-35 NE	MSE 3-NE	1.15	96160725
SQE 5-45 NE	MSE 3-NE	1.15	96160726
SQE 5-55 NE	MSE 3-NE	1.68	96160727
SQE 5-65 NE	MSE 3-NE	1.68	96160728

### Cable kits for waste dumps

**Note:** The cable must be ordered separately.

The cables are available in various lengths, see table below:

Cable length [m]	Net weight [kg]	Shipping volume [m <sup>3</sup> ]	Product number
5	0.8	0.0006	96160883
10	1.4	0.0246	96160884
15	2.0	0.0246	96160885
20	2.6	0.0246	96160886
30	3.8	0.0246	96160887
40	5.0	0.0246	96160888
50	6.3	0.0246	96160889
60	7.5	0.0476	96160890
70	8.7	0.0476	96160891
80	9.9	0.0476	96160892

## SPA-NE, SP-NE

### General data

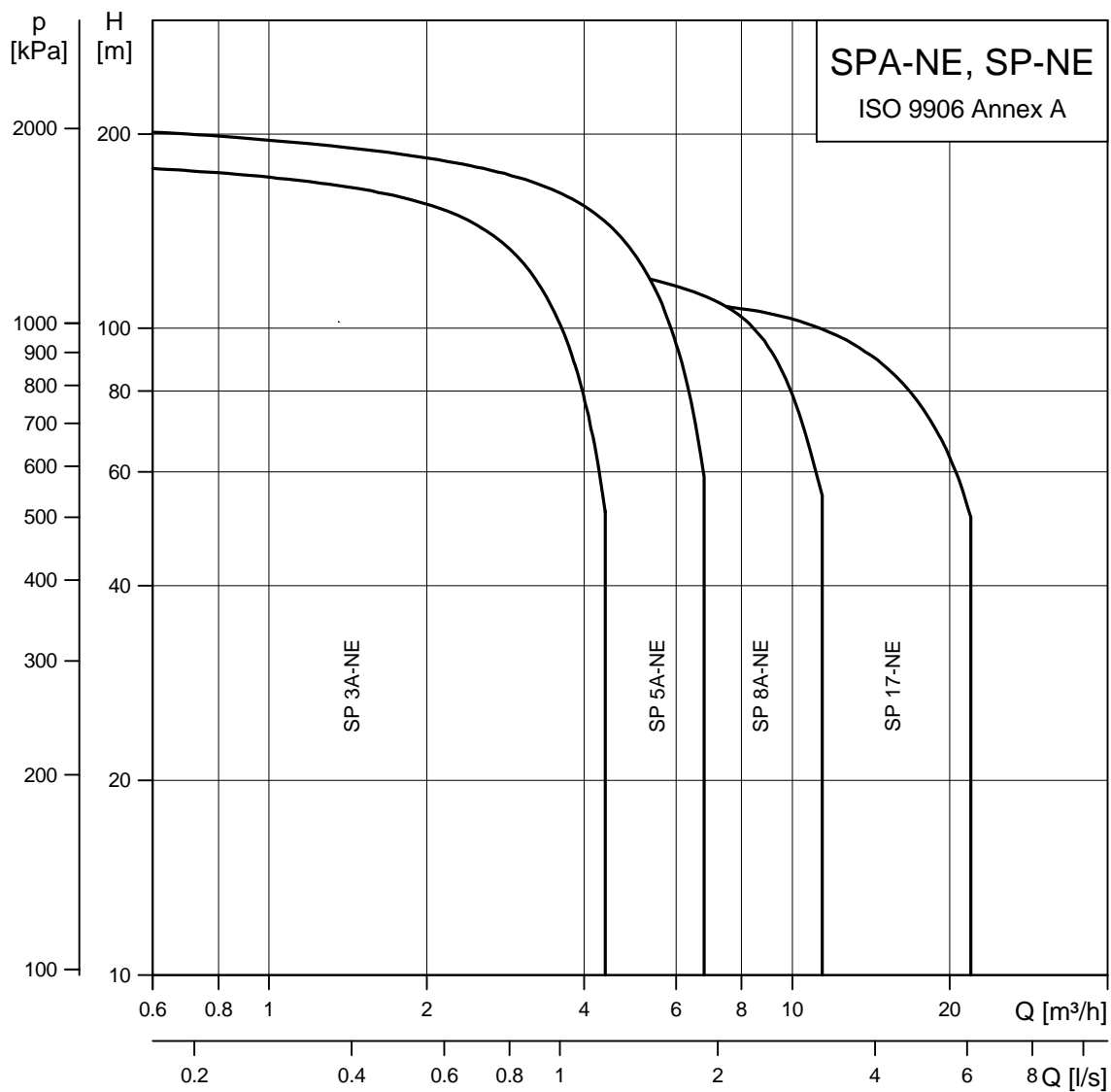

TM00 0520 2400

Fig. 31 Performance range

## Applications

Specially designed for environmental protection, the submersible SP Environmental pumps (SPA-NE, SP-NE) are resistant to chemical and oily solutions in water. The pumps are built for the withdrawal of contaminated/polluted groundwater from places such as

- dumps
- chemical depots
- industrial sites
- garages and filling stations.

Abandoned chemical waste depots as well as ordinary refuse dumps constitute an increasing threat to the world's groundwater resources. When laboratory analyses of water samples have revealed the contamination, different methods can be applied:

- The contaminated/polluted groundwater can be pumped to the surface of the ground and treated in various processes.  
The flow direction of the contaminant can be changed so that it does not flow towards a production well but towards a special extraction from where it can be withdrawn.
- In case the contaminant is hydrocarbon which is lighter than water and thus floats on top of the water, a local cone of depression can be established around the well into which the contaminant will flow and be accumulated. From such a cone of depression the contaminant can easily be recovered.

As they are made of inert materials, the SP Environmental pumps are also suitable for the following applications:

- sampling and monitoring
- pumping in water treatment systems
- pumping of industrial process water.

SP Environmental pumps are built for both continuous and intermittent operations.

## Type key

Example	SP	5	A	-	12	N	E
Pump range							
Rated flow [m <sup>3</sup> /h]							
Generation							
Number of stages							
N = Stainless steel DIN W.-Nr. 1.4401							
E = Environmental. The pump is suitable for pumping of polluted liquids.							

## Pump

Pump type	Pump diameter [mm]	Pipe connection
SP 3A-NE	101	Rp 1 1/4
SP 5A-NE	101	Rp 1 1/2
SP 8A-NE	101	Rp 2
SP 17-NE	131	Rp 2 1/2

Multistage, centrifugal pump with radial impellers directly coupled to a Grundfos submersible motor. The pump is made of stainless steel and has water-lubricated, FKM-rubber bearings.

## Motor

The 2-pole, asynchronous, squirrel-cage MS 4000 RE motor of the canned type with journal bearings is made entirely of stainless steel. Electric tolerances comply with VDE 0530.

All motors have a diameter of 95 mm.

Type designation for RE means:

## R

The motor is suitable for aggressive and slightly contaminated/polluted liquids, including liquids containing oils. Materials in stainless steel DIN W.-Nr. 1.4539.

## E

Suitable for contaminated/polluted liquids (Environmental)

Insulation class: F.

Enclosure class: IP 58.

Standard voltages: 1 x 220-230 V, 50 Hz

1 x 240 V, 50 Hz

3 x 200 V, 50 Hz

3 x 220 V, 50 Hz

3 x 380-415 V, 50 Hz

3 x 500-525 V, 50 Hz.

The motor cable is enclosed in PTFE and is one long cable without joints for increased cable life. Ceramic shaft seals are resistant to oils and chemicals.

## Pumped liquids

Thin, non-explosive liquids without abrasive particles or fibres.

Maximum sand content: 50 g/m<sup>3</sup>.

**Note:** As the SP Environmental pump has not been approved as explosion-proof, local authorities and regulations should be consulted in cases where there is any doubt whether the SP Environmental pump may be used.

## Operating conditions

Flow: 0.1-22 m<sup>3</sup>/h

Head: Max. 200 m

Operating pressure: Max. 6.0 MPa (60 bar)

Max. transportation and

storage temperature: -20 °C to +60 °C

Max. liquid temperature: See table below.

Motor	Max. temperature of pumped liquid		
	Flow velocity past motor	Vertical	Horizontal
MS 4000 RE	Free convection 0.0 m/s	20 °C	Flow sleeve recommended
MS 4000 RE	0.15 m/s	40 °C	40 °C

## Features and benefits

### Bearings with sand channels

All bearings are lubricated by the pumped liquid. The channels formed by the internal square along the shaft allow sand to be carried away by the pumped liquid.

### Inlet strainer

The inlet strainer prevents entry of particles over a certain size.

### Priming disc

The Grundfos SPA-NE, SP-NE pumps are fitted with a priming disc. That prevents dry running as the priming disc ensures lubrication of pump bearings during operation. The priming disc for the SPA-NE pump is shown to the right.

However, if the water table is lowered to a level below the pump inlet, neither pump nor motor will be protected against dry running.

### Protection against upthrust

The stop ring prevents damage to the pump during transportation and in case of up-thrust in connection with start-up.

Designed as a thrust bearing, the stop ring limits axial movement of the pump shaft.

### Service

The modular pump and motor design facilitates installation and service. The cable with plug is fitted to the motor with a nut which facilitates replacement.

Only pumps that can be certified as uncontaminated, i.e. pumps containing no hazardous and/or toxic material, may be returned to Grundfos for servicing.

To prevent injury to the health of persons involved and to the environment, a document certifying that the pump is clean is required.

Grundfos must receive this certificate before the product. Otherwise Grundfos will refuse to accept the product for servicing. Possible costs of returning the product are paid by the customer.

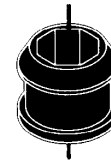

Fig. 32 Bearing

TM00 7301 1096

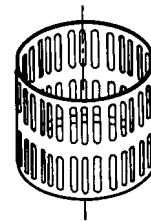

Fig. 33 Inlet strainer

TM00 7302 1096



Fig. 34 priming disc

TM01 9543 2100

## Overtemperature protection

Accessories for protection against overtemperature is available for the MS 4000 RE submersible motors. When the temperature becomes too high, the protection device will cut out the motor, thus preventing damage to pump and motor.

The motor can be restarted in two ways after a cut-out:

- manual restarting
- automatic restarting.

The Grundfos MS submersible motors except MS 402 are available with a built-in Tempcon temperature transmitter for protection against overtemperature. By means of the transmitter it is possible to read out and/or monitor the motor temperature via an MP 204 or a PR 5714 relay.

The Grundfos MS6 submersible motors can be fitted with a Pt100. The Pt100 is fitted in the motor and connected directly to the MP 204 or monitored by the PR 5714 relay.

## Protection against upthrust

In case of a very small counter-pressure in connection with start-up, there is a risk that the entire pump body may rise. This is called upthrust and it may damage both pump and motor. Therefore, both Grundfos pumps and motors are protected against upthrust as standard, preventing upthrust from occurring in the critical start-up phase. The protection consists of either a built-in stop ring or a hydraulic balancing device.

## Built-in cooling chambers

In all Grundfos MS submersible motors, type RE, efficient cooling is ensured by means of cooling chambers fitted at the top and at the bottom of the motor, and by internal circulation of motor liquid, see drawing to the right. As long as the required flow velocity past the motor is maintained (see "Operating conditions" page 46) cooling of the motor will be efficient.

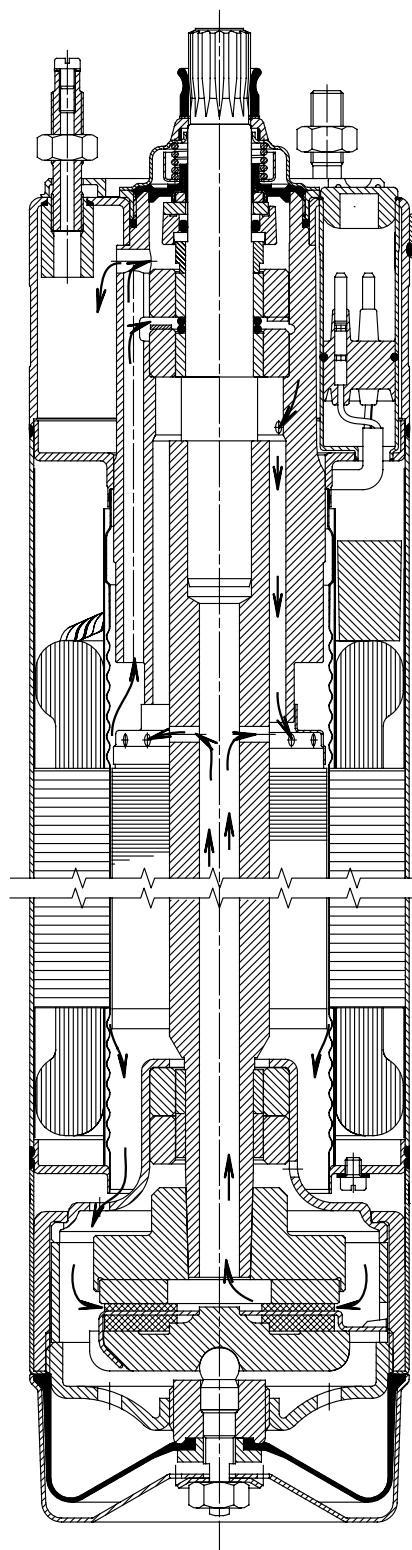

Fig. 35 MS 4000 RE, internal circulation

TM00 5698 0996



## Reduced risk of short-circuit

The embedded stator winding in the Grundfos MS submersible motor, type RE, is hermetically enclosed in stainless steel. The result is high mechanical stability and optimum cooling. In addition, the risk of short-circuit of the windings caused by condensed water is eliminated.

## Shaft seal

The ceramic/tungsten-carbide shaft seal provides optimum sealing and wear resistance as well as long life.

The large surface as well as the sand shield of the spring-loaded shaft seal ensure minimum exchange of pumped liquid and motor liquid and no penetration of particles.

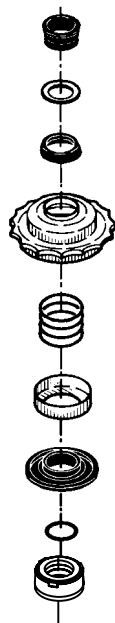

TM00 7306 2100

Fig. 36 Shaft seal, MS 4000

## Curve conditions

The guidelines below apply to the performance curves on pages 50 to 57:

### General

- Curve tolerances are according to ISO 9906, Annex A.
- The performance curves show the pump performance at actual speed, cf. standard motor range.  
The speed of 4" motors is approximately:  
 $n = 2870 \text{ min}^{-1}$ .
- The measurements have been made with airless water at a temperature of 20 °C.  
The curves apply to a kinematic viscosity of  $1 \text{ mm}^2/\text{s}$  (1 cSt).  
When pumping liquids with a density higher than that of water, a motor with a correspondingly higher output must be used.
- The **bold** curves show the **recommended** performance range.
- The performance curves are inclusive of possible losses such as non-return valve loss.

### SP curves

- **Q/H:** The curves are inclusive of valve and inlet losses at the actual speed.  
Operation without non-return valve will increase the actual head at nominal performance by 0.5 to 1.0 m.
- **Power curve:** The  $P_2$  curve shows the pump power input at the actual speed of each individual pump size.
- **Efficiency curve:** The  $\eta$  curve shows, the pump efficiency per stage.

# Performance curves

Submersible pumps  
SP 3A-NE

## SP 3A-NE

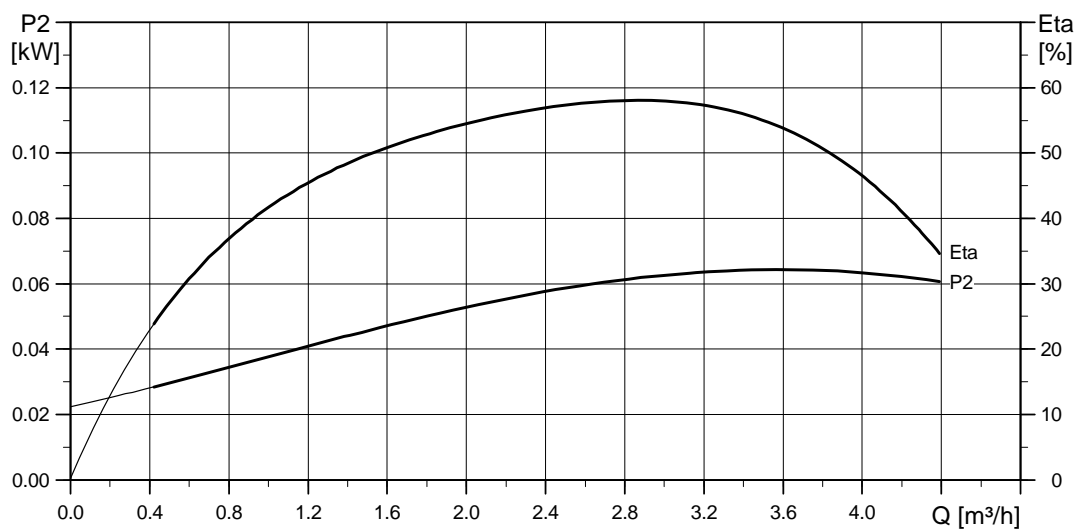
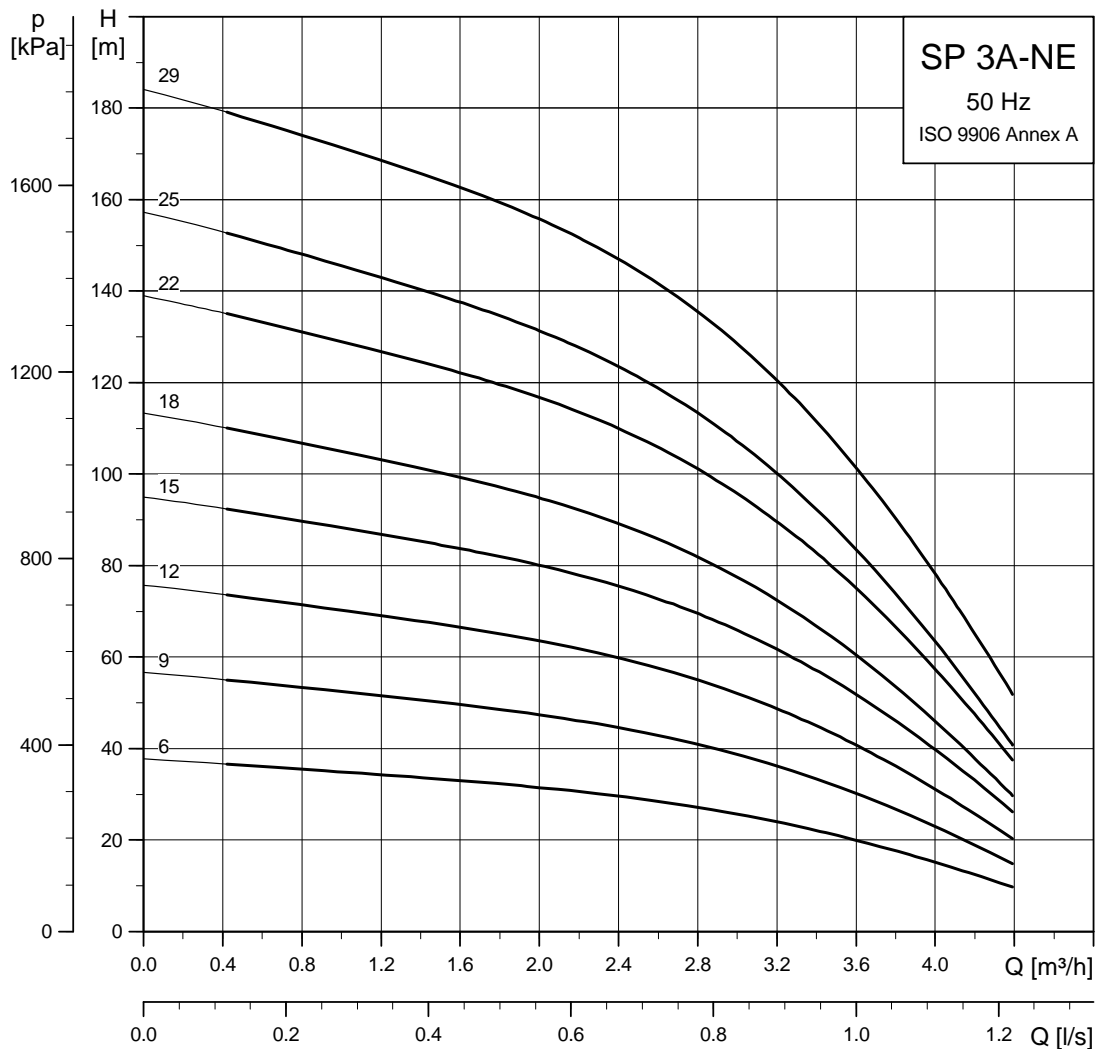

TM01 3498 2500

### Dimensions and weights

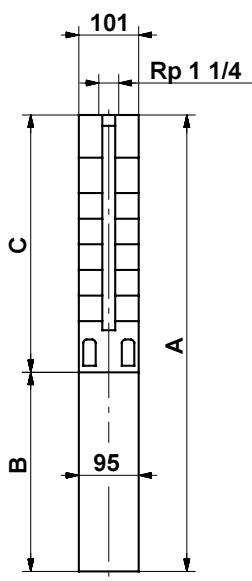

TM00 0955 1196

Pump type	Motor		C	Dimensions [mm]				Net weight [kg]	
	Type	Power [kW]		B		A		Net weight [kg]	
				1 x 230 V	3 x 400 V	1 x 230 V	3 x 400 V	1 x 230 V	3 x 400 V
SP 3A-6 NE	MS 4000 RE	2.2	326	573		899		26	
SP 3A-6 NE	MS 4000 RE	0.75	326		398		724		18
SP 3A-9 NE	MS 4000 RE	2.2	389	573		962		27	
SP 3A-9 NE	MS 4000 RE	0.75	389		398		787		19
SP 3A-12 NE	MS 4000 RE	2.2	452	573		1025		28	
SP 3A-12 NE	MS 4000 RE	0.75	452		398		850		20
SP 3A-15 NE	MS 4000 RE	2.2	515	573		1088		29	
SP 3A-15 NE	MS 4000 RE	1.1	515		413		928		22
SP 3A-18 NE	MS 4000 RE	2.2	578	573		1151		30	
SP 3A-18 NE	MS 4000 RE	1.1	578		413		991		23
SP 3A-22 NE	MS 4000 RE	2.2	662	573		1235		31	
SP 3A-22 NE	MS 4000 RE	1.5	662		413		1075		24
SP 3A-25 NE	MS 4000 RE	2.2	725	573		1298		32	
SP 3A-25 NE	MS 4000 RE	1.5	725		413		1138		25
SP 3A-29 NE	MS 4000 RE	2.2	809	573	453	1382	1262	33	28

101 mm = Maximum diameter of pump, inclusive of cable guard and motor

### Electrical data

3 x 400 V, 50 Hz

Pump type	Motor type	Power [kW]	Rated current $I_{1/1}$ [A]	Motor efficiency [%]			Power factor [%]			$\frac{I_{st}}{I_{1/1}}$
				$\eta_{50\%}$	$\eta_{75\%}$	$\eta_{100\%}$	$\cos \phi_{50\%}$	$\cos \phi_{75\%}$	$\cos \phi_{100\%}$	
SP 3A-6 NE	MS 4000 RE	0.75	1.84	68.1	71.6	72.8	0.69	0.79	0.84	4.9
SP 3A-9 NE	MS 4000 RE	0.75	1.84	68.1	71.6	72.8	0.69	0.79	0.84	4.9
SP 3A-12 NE	MS 4000 RE	0.75	1.84	68.1	71.6	72.8	0.69	0.79	0.84	4.9
SP 3A-15 NE	MS 4000 RE	1.1	2.75	70.3	74.0	74.4	0.62	0.74	0.82	5.1
SP 3A-18 NE	MS 4000 RE	1.1	2.75	70.3	74.0	74.4	0.62	0.74	0.82	5.1
SP 3A-22 NE	MS 4000 RE	1.5	4.00	69.1	72.7	73.7	0.55	0.69	0.78	4.3
SP 3A-25 NE	MS 4000 RE	1.5	4.00	69.1	72.7	73.7	0.55	0.69	0.78	4.3
SP 3A-29 NE	MS 4000 RE	2.2	6.05	67.9	73.1	74.5	0.49	0.63	0.74	4.5

### Electrical data

1 x 230 V, 50 Hz

Motor type	Power [kW]	Rated current $I_{1/1}$ [A]	Motor efficiency [%]			Power factor [%]			$\frac{I_{st}}{I_{1/1}}$	Control box for 3-wire motors
			$\eta_{50\%}$	$\eta_{75\%}$	$\eta_{100\%}$	$\cos \phi_{50\%}$	$\cos \phi_{75\%}$	$\cos \phi_{100\%}$		
MS 4000 RE	2.2	14.0	67.0	73.0	75.0	0.91	0.94	0.96	4.4	SA-SPM 3

# Performance range

Submersible pumps  
SP 5A-NE

## SP 5A-NE

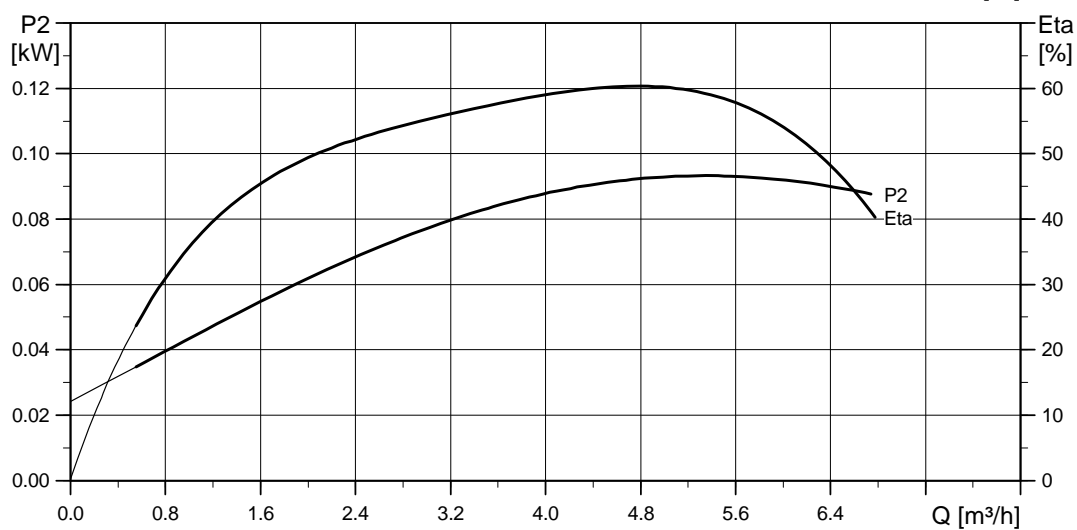
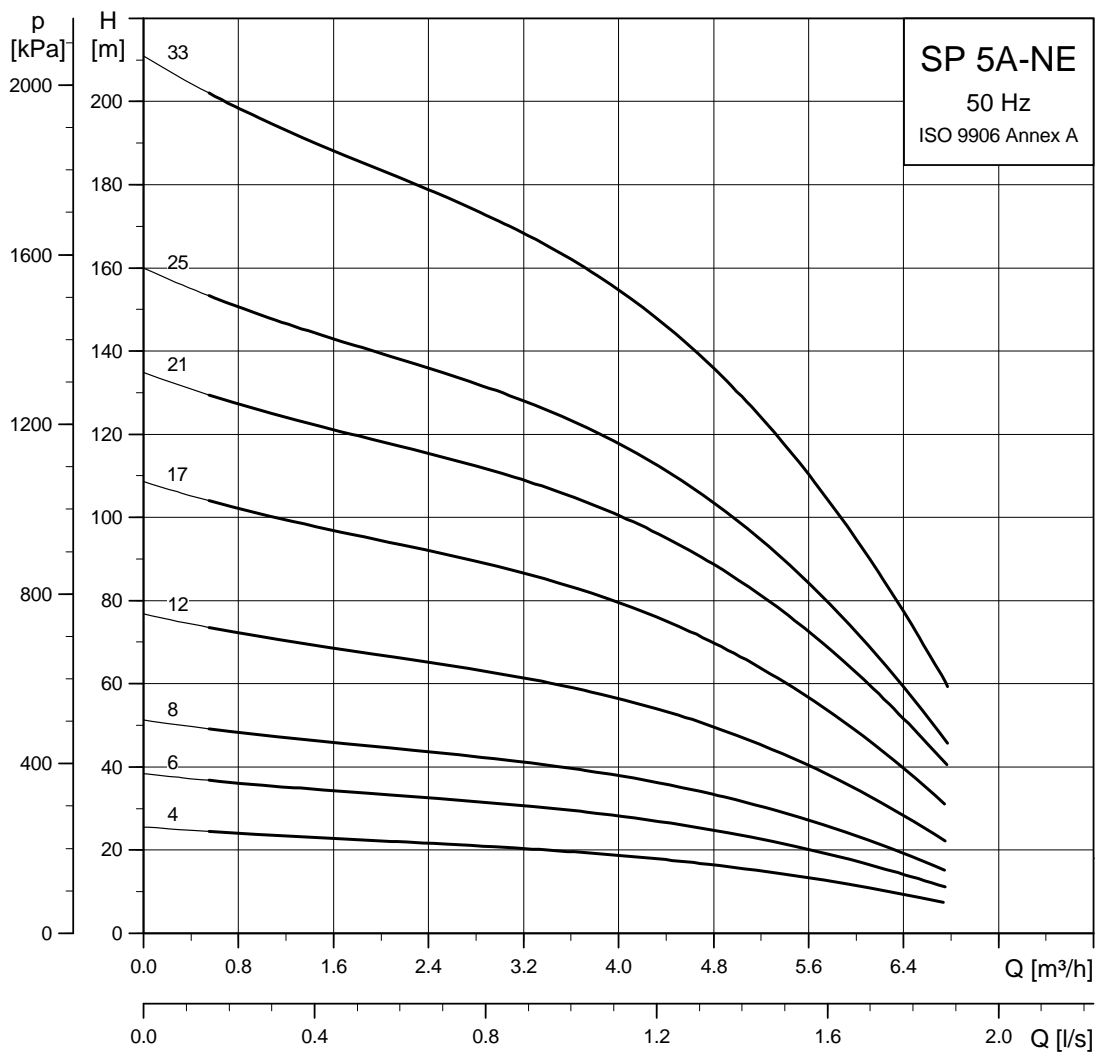

TM01 3499 2500

### Dimensions and weights

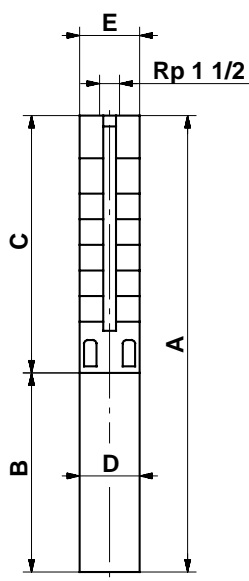

TM00 0956 1196

Pump type	Motor		Dimensions [mm]						Net weight [kg]		
	Type	Power [kW]	C	B		A		D	E	Net weight [kg]	
				1 x 230 V	3 x 400 V	1 x 230 V	3 x 400 V			1 x 230 V	3 x 400 V
SP 5A-4 NE	MS 4000 RE	2.2	284	573		857		95	101	25	
SP 5A-4 NE	MS 4000 RE	0.75	284		398		682	95	101		17
SP 5A-6 NE	MS 4000 RE	2.2	326	573		899		95	101	26	
SP 5A-6 NE	MS 4000 RE	0.75	326		398		724	95	101		18
SP 5A-8 NE	MS 4000 RE	2.2	368	573		941		95	101	27	
SP 5A-8 NE	MS 4000 RE	0.75	368		398		766	95	101		19
SP 5A-12 NE	MS 4000 RE	2.2	452	573		1025		95	101	28	
SP 5A-12 NE	MS 4000 RE	1.1	452		413		865	95	101		21
SP 5A-17 NE	MS 4000 RE	2.2	557	573		1130		95	101	29	
SP 5A-17 NE	MS 4000 RE	1.5	557		413		970	95	101		22
SP 5A-21 NE	MS 4000 RE	2.2	641	573	453	1214	1094	95	101	30	25
SP 5A-25 NE	MS 4000 RE	2.2	725	573	453	1298	1178	95	101	32	27
SP 5A-33 NE	MS 4000 RE	3.0	893		493		1386	95	101		30

E = Maximum diameter of pump, inclusive of cable guard and motor.

### Electrical data 3 x 400 V, 50 Hz

Pump type	Motor type	Power [kW]	Rated current $I_{1/1}$ [A]	Motor efficiency [%]			Power factor [%]			$\frac{I_{st}}{I_{1/1}}$
				$\eta_{50\%}$	$\eta_{75\%}$	$\eta_{100\%}$	$\cos \varphi_{50\%}$	$\cos \varphi_{75\%}$	$\cos \varphi_{100\%}$	
SP 5A-4 NE	MS 4000 RE	0.75	1.84	68.1	71.6	72.8	0.69	0.79	0.84	4.9
SP 5A-6 NE	MS 4000 RE	0.75	1.84	68.1	71.6	72.8	0.69	0.79	0.84	4.9
SP 5A-8 NE	MS 4000 RE	0.75	1.84	68.1	71.6	72.8	0.69	0.79	0.84	4.9
SP 5A-12 NE	MS 4000 RE	1.1	2.75	70.3	74.0	74.4	0.62	0.74	0.82	5.1
SP 5A-17 NE	MS 4000 RE	1.5	4.00	69.1	72.7	73.7	0.55	0.69	0.78	4.3
SP 5A-21 NE	MS 4000 RE	2.2	6.05	67.9	73.1	74.5	0.49	0.63	0.74	4.5
SP 5A-25 NE	MS 4000 RE	2.2	6.05	67.9	73.1	74.5	0.49	0.63	0.74	4.5
SP 5A-33 NE	MS 4000 RE	3.0	7.85	71.5	74.5	75.2	0.53	0.67	0.77	4.5

### Electrical data 1 x 230 V, 50 Hz

Motor type	Power [kW]	Rated current $I_{1/1}$ [A]	Motor efficiency [%]			Power factor [%]			$\frac{I_{st}}{I_{1/1}}$	Control box for 3-wire motors
			$\eta_{50\%}$	$\eta_{75\%}$	$\eta_{100\%}$	$\cos \varphi_{50\%}$	$\cos \varphi_{75\%}$	$\cos \varphi_{100\%}$		
MS 4000 (RE)	2.2	14.0	67.0	73.0	75.0	0.91	0.94	0.96	4.4	SA-SPM 3

# Performance range

Submersible pumps  
SP 8A-NE

## SP 8A-NE

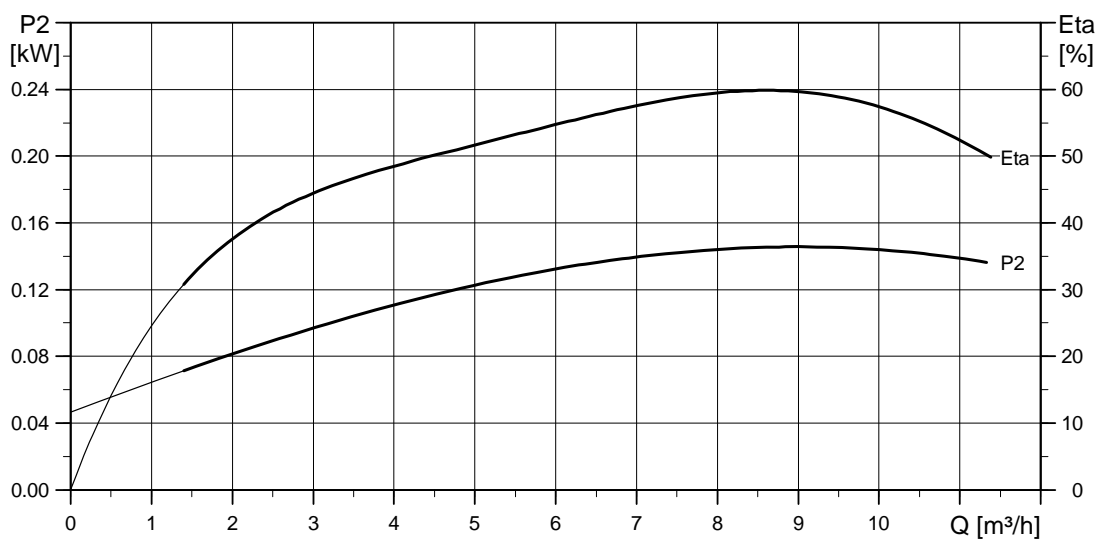
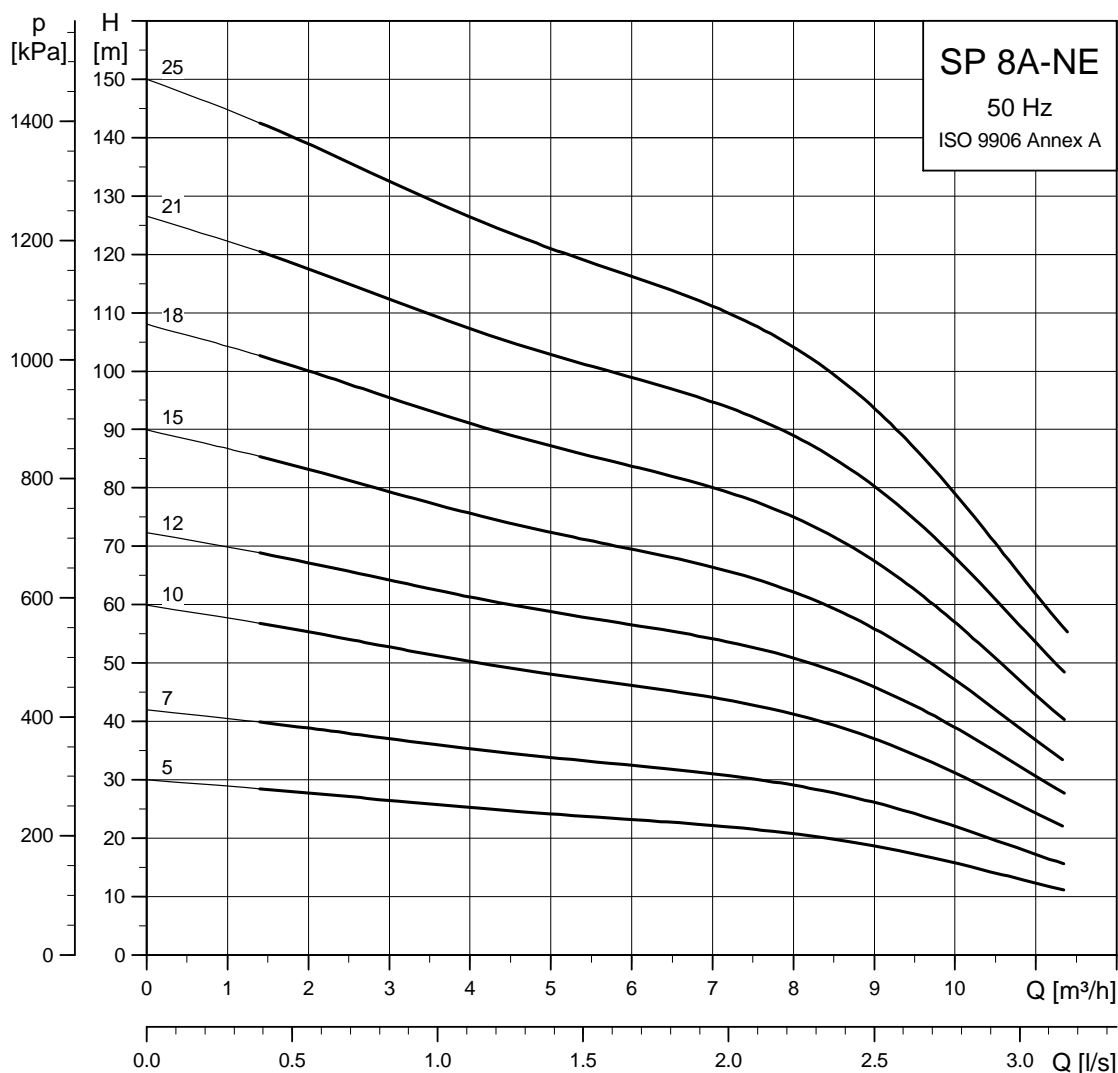

TM01 3500 2500

### Dimensions and weights

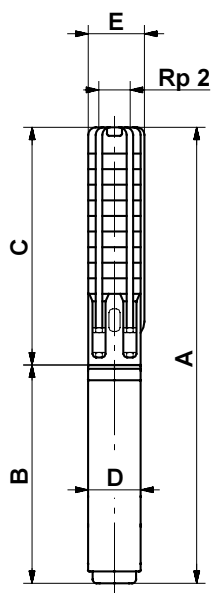

TM00 0957 1196

Pump type	Motor		Dimensions [mm]					Net weight [kg]		
	Type	Power [kW]	C	B		A		D	E	
				1 x 230 V	3 x 400 V	1 x 230 V	3 x 400 V			
SP 8A-5 NE	MS 4000 RE	2.2	409	573		982	95	101	27	
SP 8A-5 NE	MS 4000 RE	0.75	409		398		95	101	19	
SP 8A-7 NE	MS 4000 RE	2.2	493	573		1066	95	101	28	
SP 8A-7 NE	MS 4000 RE	1.1	493		413		95	101	21	
SP 8A-10 NE	MS 4000 RE	2.2	619	573		1192	95	101	30	
SP 8A-10 NE	MS 4000 RE	1.5	619		413		95	101	23	
SP 8A-12 NE	MS 4000 RE	2.2	703	573	453	1276	1156	95	101	30
SP 8A-15 NE	MS 4000 RE	2.2	829	573	453	1402	1282	95	101	32
SP 8A-18 NE	MS 4000 RE	3.0	955				1448	95	101	29
SP 8A-21 NE	MS 4000 RE	4.0	1081		573		1654	95	101	35
SP 8A-25 NE	MS 4000 RE	4.0	1249		573		1822	95	101	37

E = Maximum diameter of pump, inclusive of cable guard and motor.

### Electrical data 3 x 400 V, 50 Hz

Pump type	Motor type	Power [kW]	Rated current $I_{1/1}$ [A]	Motor efficiency [%]			Power factor [%]			$\frac{I_{st}}{I_{1/1}}$
				$\eta_{50\%}$	$\eta_{75\%}$	$\eta_{100\%}$	$\cos \varphi_{50\%}$	$\cos \varphi_{75\%}$	$\cos \varphi_{100\%}$	
SP 8A-5 NE	MS 4000 RE	0.75	1.84	68.1	71.6	72.8	0.69	0.79	0.84	4.9
SP 8A-7 NE	MS 4000 RE	1.1	2.75	70.3	74.0	74.4	0.62	0.74	0.82	5.1
SP 8A-10 NE	MS 4000 RE	1.5	4.00	69.1	72.7	73.7	0.55	0.69	0.78	4.3
SP 8A-12 NE	MS 4000 RE	2.2	6.05	67.9	73.1	74.5	0.49	0.63	0.74	4.5
SP 8A-15 NE	MS 4000 RE	2.2	6.05	67.9	73.1	74.5	0.49	0.63	0.74	4.5
SP 8A-18 NE	MS 4000 RE	3.0	7.85	71.5	74.5	75.2	0.53	0.67	0.77	4.5
SP 8A-21 NE	MS 4000 RE	4.0	9.60	77.3	78.4	78.0	0.57	0.71	0.80	4.8
SP 8A-25 NE	MS 4000 RE	4.0	9.60	77.3	78.4	78.0	0.57	0.71	0.80	4.8

### Electrical data 1 x 230 V, 50 Hz

Motor type	Power [kW]	Rated current $I_{1/1}$ [A]	Motor efficiency [%]			Power factor [%]			$\frac{I_{st}}{I_{1/1}}$	Control box for 3-wire motors
			$\eta_{50\%}$	$\eta_{75\%}$	$\eta_{100\%}$	$\cos \varphi_{50\%}$	$\cos \varphi_{75\%}$	$\cos \varphi_{100\%}$		
MS 4000 (RE)	2.2	14.0	67.0	73.0	75.0	0.91	0.94	0.96	4.4	SA-SPM 3

# Performance range

Submersible pumps  
SP 17-NE

## SP 17-NE

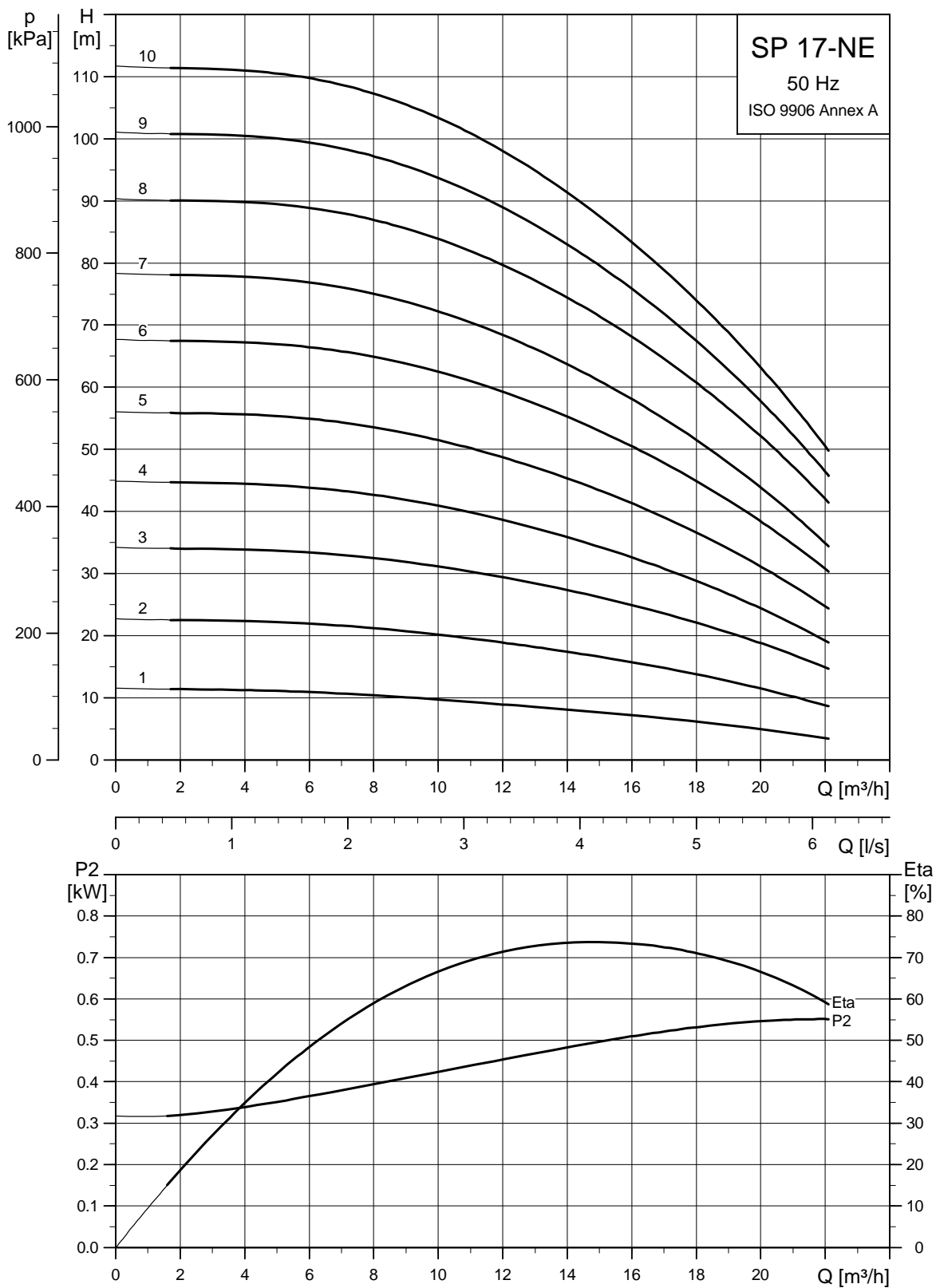

TM01 3501 2500



### Dimensions and weights

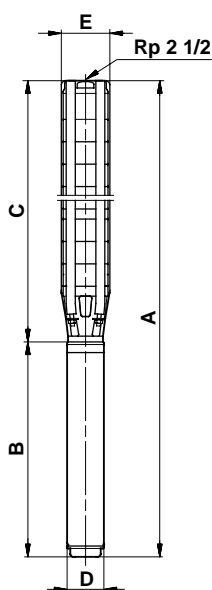

TM02 7450 3503

E = Maximum diameter of pump, inclusive of cable guard and motor.

Pump type	Motor		Dimensions [mm]						Net weight [kg]		
	Type	Power [kW]	C	B		A		D	E	Net weight [kg]	
				1 x 230 V	3 x 400 V	1 x 230 V	3 x 400 V			1 x 230 V	3 x 400 V
SP 17-1 NE	MS 4000 RE	2.2	314	573		887		95	131	25	
SP 17-1 NE	MS 4000 RE	0.75	314		398		712	95	131		17
SP 17-2 NE	MS 4000 RE	2.2	374	573		947		95	131	27	
SP 17-2 NE	MS 4000 RE	1.1	374		413		787	95	131		20
SP 17-3 NE	MS 4000 RE	2.2	435	573	453	1008	888	95	131	28	23
SP 17-4 NE	MS 4000 RE	2.2	495	573	453	1068	948	95	131	29	24
SP 17-5 NE	MS 4000 RE	3.0	556		493		1049	95	131		26
SP 17-6 NE	MS 4000 RE	4.0	616		573		1189	95	131		31
SP 17-7 NE	MS 4000 RE	4.0	677		573		1250	95	131		33
SP 17-8 NE	MS 4000 RE	5.5	737		673		1410	95	131		39
SP 17-9 NE	MS 4000 RE	5.5	798		673		1471	95	131		40
SP 17-10 NE	MS 4000 RE	5.5	858		673		1531	95	131		41

### Electrical data

3 x 400 V, 50 Hz

Pump type	Motor type	Power [kW]	Rated current $I_{1/1}$ [A]	Motor efficiency [%]			Power factor [%]			$\frac{I_{st}}{I_{1/1}}$
				$\eta_{50\%}$	$\eta_{75\%}$	$\eta_{100\%}$	$\cos \phi_{50\%}$	$\cos \phi_{75\%}$	$\cos \phi_{100\%}$	
SP 17-1 NE	MS 4000 RE	0.75	1.80	68.1	71.6	72.8	0.69	0.79	0.84	4.9
SP 17-2 NE	MS 4000 RE	1.1	2.75	70.3	74.0	74.4	0.62	0.74	0.82	5.1
SP 17-3 NE	MS 4000 RE	2.2	6.05	67.9	73.1	74.5	0.49	0.63	0.74	4.5
SP 17-4 NE	MS 4000 RE	2.2	6.05	67.9	73.1	74.5	0.49	0.63	0.74	4.5
SP 17-5 NE	MS 4000 RE	3.0	7.85	71.5	74.5	75.2	0.53	0.67	0.77	4.5
SP 17-6 NE	MS 4000 RE	4.0	9.60	77.3	78.4	78.0	0.57	0.71	0.80	4.8
SP 17-7 NE	MS 4000 RE	4.0	9.60	77.3	78.4	78.0	0.57	0.71	0.80	4.8
SP 17-8 NE	MS 4000 RE	5.5	13.0	78.5	80.1	79.8	0.57	0.72	0.81	4.9
SP 17-9 NE	MS 4000 RE	5.5	13.0	78.5	80.1	79.8	0.57	0.72	0.81	4.9
SP 17-10 NE	MS 4000 RE	5.5	13.0	78.5	80.1	79.8	0.57	0.72	0.81	4.9

### Electrical data

1 x 230 V, 50 Hz

Motor type	Power [kW]	Rated current $I_{1/1}$ [A]	Motor efficiency [%]			Power factor [%]			$\frac{I_{st}}{I_{1/1}}$	Control box for 3-wire motors
			$\eta_{50\%}$	$\eta_{75\%}$	$\eta_{100\%}$	$\cos \phi_{50\%}$	$\cos \phi_{75\%}$	$\cos \phi_{100\%}$		
MS 4000 (RE)	2.2	14.0	67.0	73.0	75.0	0.91	0.94	0.96	4.4	SA-SPM 3

## Technical data

### Material specification (pump)

Pos.	Component	Material	DIN W.-Nr.
1	Valve casing	Stainless steel	1.4401
2	Top bearing	FKM	
3	Chamber	Stainless steel	1.4401
4	Intermediate bearing	FKM	
5	Impeller	Stainless steel	1.4401
6	Suction interconnector	Stainless steel	1.4401
7	Shaft	Stainless steel	1.4401
8	Strap	Stainless steel	1.4401

### Material specification (motor)

Pos.	Component	Material	DIN W.-Nr.
9	Radial bearing	Ceramics/ tungsten carbide	
10	Thrust bearings	Carbon/ceramics	
11	Shaft end	Stainless steel	1.4462
12	Stator housing	Stainless steel	1.4539
13	End shield	Stainless steel	1.4539
	O-rings	FKM	

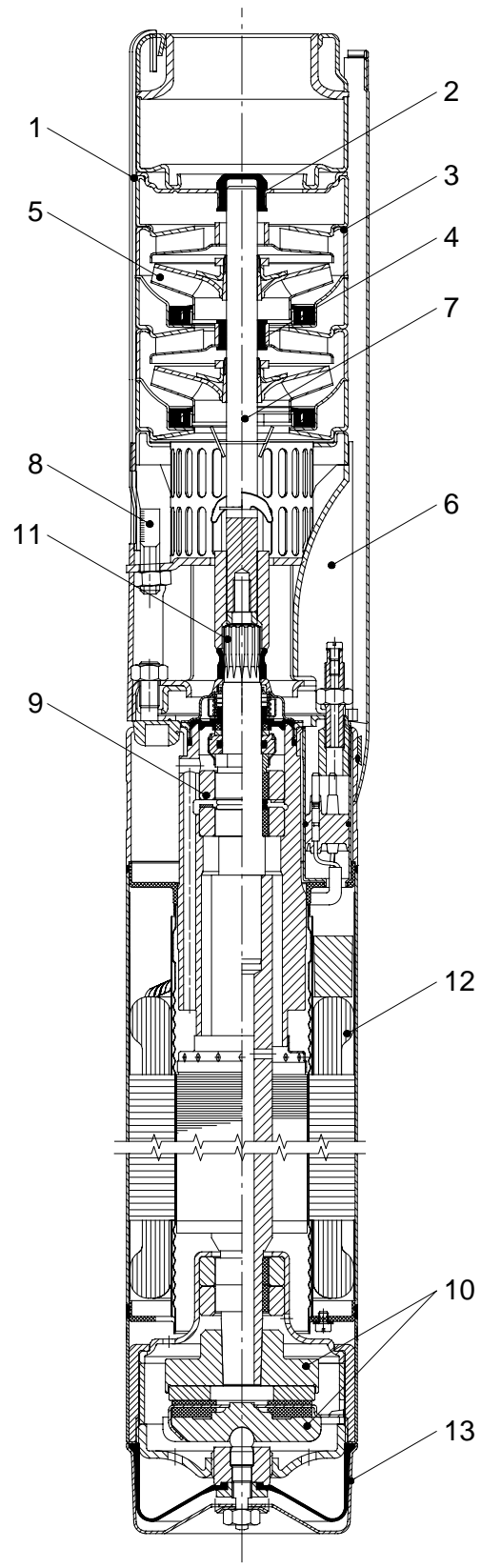

Fig. 37 SP 8A-NE

TM01 9176 1300

## Accessories

### MP 204

The MP 204 is an electronic motor protector, designed for the protection of an asynchronous motor or a pump.

The motor protector consists of:

- a cabinet incorporating transformers and electronics
- a control panel with operating buttons and display for reading of data.

The MP 204 operates with two sets of limits:

- a set of warning limits and
- a set of trip limits.

If one or more of the warning limits are exceeded, the motor continues to run, but the warnings will appear in the MP 204 display.

Some values only have a warning limit.

The warning can also be read out by means of the Grundfos R100 remote control.

If one of the trip limits is exceeded, the trip relay will stop the motor. At the same time, the signal relay is operating to indicate that the limit has been exceeded.

### Applications

The MP 204 can be used as a stand-alone motor protector.

The MP 204 can be monitored via a Grundfos GENIbus.

The power supply to the MP 204 is in parallel with the supply to the motor. Motor currents up to 120 A are passed directly through the MP 204. The MP 204 protects the motor primarily by measuring the motor current by means of a true RMS measurement. The MP 204 disconnects the contactor if, for example, the current exceeds the preset value.

Secondarily, the pump is protected via temperature measuring by a Tempcon sensor, a Pt100/Pt1000 sensor and a PTC sensor/thermal switch.

The MP 204 is designed for single- and three-phase motors. In single-phase motors, the starting and run capacitors are also measured. Cos  $\varphi$  is measured in both single- and three-phase systems.

### Benefits

The MP 204 offers these benefits:

- suitable for both single- and three-phase motors
- dry-running protection
- overload protection
- very high accuracy
- made for submersible pumps.

### The MP 204 - many monitoring options

The MP 204 monitors the following parameters:

- Insulation resistance before start-up
- Temperature (Tempcon, Pt sensor and PTC/thermal switch)
- Overload/underload
- Overvoltage/undervoltage
- Phase sequence
- Phase failure
- Power factor
- Power consumption
- Harmonic distortion
- Operating hours and number of starts.



TM03 1471 2205

Fig. 38 MP 204

### Product numbers

Product	Product number
MP 204	96079927
R100	96615297

## Functions

- Phase-sequence monitoring
- Indication of current or temperature (user selection)
- Indication of temperature in °C or °F (user selection)
- 4-digit, 7-segment display
- Setting and status reading with the R100
- Setting and status reading via GENIbus.

## Tripping conditions

- Overload
- Underload (dry running)
- Temperature (Tempcon, Pt sensor and PTC/thermal switch)
- Phase failure
- Phase sequence
- Overvoltage
- Undervoltage
- Power factor ( $\cos \varphi$ )
- Current unbalance.

## Warnings

- Overload
- Underload
- Temperature (Tempcon and Pt sensor)
- Overvoltage
- Undervoltage
- Power factor ( $\cos \varphi$ )  
**Note:** In connection with single- and three-phase connection.
- Run capacitor (single-phase operation)
- Starting capacitor (single-phase operation)
- Loss of communication in network
- Harmonic distortion.

## Learning function

- Phase sequence (three-phase operation)
- Run capacitor (single-phase operation)
- Starting capacitor (single-phase operation)
- Identification and measurement of Pt100/Pt1000 sensor circuit.

## External current transformers

When fitted with external current transformers, the MP 204 can handle currents from 120 to 999 A. Grundfos can supply approved current transformers from stock (200/5A, 300/5A, 500/5A, 750/5A, 1000/5A).

## R100 remote control

The R100 remote control from Grundfos allows for wireless infrared remote control of your MP 204 motor protector.

With the R100, you get access to a full range of options such as factory setting adjustment, service and fault finding.

## Ready for bus communication

The MP 204 allows for monitoring and communication via GENIbus – a Grundfos-designed bus for exchange of pump data, alarms, status information, and setpoints. This enables users to connect the MP 204 to, for instance, SCADA systems.

## Technical data - MP 204

Enclosure class	IP 20
Ambient temperature	-20 °C to +60 °C
Relative air humidity	99 %
Voltage range	100-480 VAC
Current range	3-999 A
Frequency	50 to 60 Hz
IEC trip class	1-45
Special Grundfos trip class	0.1 to 30 s
Voltage variation	-25 %/+15 % of nominal voltage
Approvals	EN 60947, EN 60335, UL/CSA 508
Marking	CE, cUL, C-tick
Consumption	Max. 5 W
Plastic type	Black PC / ABS

	Measuring range	Accuracy	Resolution
Current without external current transformers	3-120 A	± 1%	0.1 A
Current with external current transformers	120-999 A	± 1%	1 A
Phase-to-phase voltage	80-610 VAC	± 1%	1 V
Frequency	47-63 Hz	± 1%	0.5 Hz
Power	0-1 MW	± 2%	1 W
Power factor	0-0.99	± 2%	0.01
Energy consumption	0-4 x 10 <sup>9</sup> kWh	± 5%	1 kWh

IO 112	Description	Product number
	<p>The IO 112 is a measuring module and a 1-channel protection unit for use in connection with the MP 204 motor protection unit. The module can be used for protection of pump against other factors than the electrical conditions, for instance dry-running. It can also be used as a stand-alone protection module.</p> <p>The IO 112 interface has three inputs for measured values one potentiometer for setting of limits indicator lights indicating the</p> <ul style="list-style-type: none"> <li>• measured value of the input</li> <li>• value of the limit set</li> <li>• alarm source</li> <li>• pump status.</li> </ul> <p><b>Electrical data:</b></p> <ul style="list-style-type: none"> <li>• Supply voltage: 24 VAC ±10% 50/60 Hz or 24 VDC ±10%</li> <li>• Supply current: Min. 2.4 A; max. 8 A</li> <li>• Power consumption: Max. 5 W</li> <li>Ambient temperature: -25°C to +65°C</li> <li>• Enclosure class: IP20</li> </ul>	96651601

## Control functions

This table describes the protection provided by the MP 204.

Control parameters	Function	Problem	Advantages
<b>Temperature</b>	<p><b>MS</b> The motor temperature is measured by means of the built-in Tempcon temperature transmitter and a signal is sent to the MP 204 via the phase leads. In the MP 204, the measured temperature is compared with the factory-set value (75 °C).</p> <p><b>MMS</b> The motor temperature is measured by means of the Pt100. The signal is sent to the MP 204 where the measured temperature is compared with the factory-set value. Temperature protection requires a submersible motor with a Pt100.</p> <p>The motor temperature must be monitored during frequency converter operation.</p>	Overload, frequent starts/stops, operation against blocked discharge pipe, insufficient flow velocity past the motor.	Longer motor life, safe operating conditions, service indication.
	<p><b>Overvoltage/undervoltage</b></p> <p>If the set trip value is exceeded, the motor will stop.</p>	The installation is close to a transformer. The mains do not absorb load variations.	Important installation parameter, possibility of improving operating conditions.
<b>Overload</b>	The motor power input is measured on each of the three phases. The registered power input is an average of these three values. If the factory-set value is exceeded, the motor will stop.	Incorrect sizing of pump/motor, voltage supply failure, defective cable, blocking, wear or corrosion.	Longer pump life, safe operating conditions, service indication.
<b>Underload (dry running)</b>	The motor power input is measured on each of the three phases. The registered power input is an average of these three values. If the average value is lower than the factory-set value, the motor will stop.	Pump exposed to dry running or underload, for example caused by wear.	Conventional dry-running protection is no longer necessary, no extra cables.
<b>Current unbalance</b>	The power input of the motor is measured on each of the three phases.	Mains load is uneven, incipient motor defect, phase voltages diverging.	Motor protection against overload, service indication.
<b>Phase sequence</b>	The MP 204 and motor are installed so that the phase sequence corresponds to correct direction of rotation. MP 204 monitors changes in the phase sequence.	Two phases are wrongly connected.	Ensures correct pump performance.
<b>Phase failure</b>	The MP 204 checks the phases connected, phase failure will cause an alarm.	Phase failure.	Indication of phase failure, and alarm.

## R100 menus

### 0. GENERAL

See the operating instructions for the R100.

### 1. OPERATION

- Operating mode
- Actual trip
- Actual warning 1
- Actual warning 2
- Alarm log 1
- Alarm log 2
- Alarm log 3
- Alarm log 4
- Alarm log 5.

### 2. STATUS

Display of

- Supply overview
- Average current
- Average voltage
- Tempcon sensor
- Pt100/Pt1000 sensor
- **Power input and energy consumption** (described in the following)
- Energy trip counter
- Phase sequence
- Current unbalance
- Operating hours and number of starts
- Trip counter of hours and starts
- Starting capacitor
- Run capacitor
- Insulation resistance
- Cos  $\varphi$
- Harmonic distortion.

### 3. LIMITS

Display and setting of warning and trip limits.

- Tempcon sensor
- Pt sensor
- Tripping current
- Current warning
- Nominal voltage
- Voltage limits
- Current unbalance
- Starting capacitor
- Run capacitor
- Insulation resistance
- Cos  $\varphi$  trip
- Cos  $\varphi$  warning.

## 4. INSTALLATION

Setting and display of

- Supply mains
- **Trip class** (described in the following)
- Trip delay
- External current transformers
- Power-on delay
- **Restarting** (described in the following)
- **Automatic restarting** (described in the following)
- Tempcon sensor
- Pt sensor
- Insulation resistance measurement
- PTC/thermal switch
- Resetting of trip counters
- Service interval
- Number of automatic restarts
- Units/display
- MP 204 display
- GENIbus ID number
- Learning function.

### Power input and energy consumption

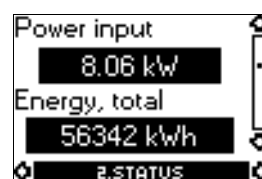

Actual power input and motor energy consumption.

The energy consumption is an accumulated value which cannot be reset.

The power is calculated like this:

$$U_{\text{average}} = \frac{U_{L1-L2} + U_{L2-L3} + U_{L3-L1}}{3} [\text{V}]$$

$$I_{\text{average}} = \frac{I_{L1} + I_{L2} + I_{L3}}{3} [\text{A}]$$

$$\cos \varphi_{\text{average}} = \frac{\cos \varphi_{L1} + \cos \varphi_{L2} + \cos \varphi_{L3}}{3} [-]$$

$$P = U_{\text{average}} \cdot I_{\text{average}} \cdot \sqrt{3} \cdot \cos \varphi_{\text{average}} [\text{W}]$$

## Trip class

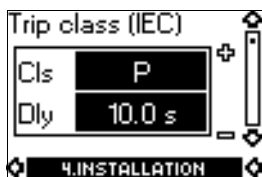

Line 1: Select IEC trip class (1 to 45).

If manual indication of trip delay in the case of overload is required, select trip class "P".

### Factory setting:

- Cls (trip class): P.

Line 2: Select trip delay.

### Factory setting:

- Dly (trip delay): 10 s.

## Restarting



Set whether restarting after tripping is to be

- **Automatic** (factory setting)
- *Manual*.

Setting of time, see section "Automatic restarting".

## Automatic restarting



Set the time after which the MP 204 is to attempt automatic restarting of motor after cut-out.

The time runs from the moment when the value which triggered the fault has returned to normal.

### Factory setting:

- 300 s.



### G100 gateway for communication with Grundfos products

The G100 gateway offers a wide selection of options for integration of Grundfos products provided with GENI-bus interface into main control and monitoring systems.

The G100 enables a pump installation to meet future demands for optimum pump operation in terms of reliability, operating costs, centralisation and automation.



Fig. 39 G100

GR5940

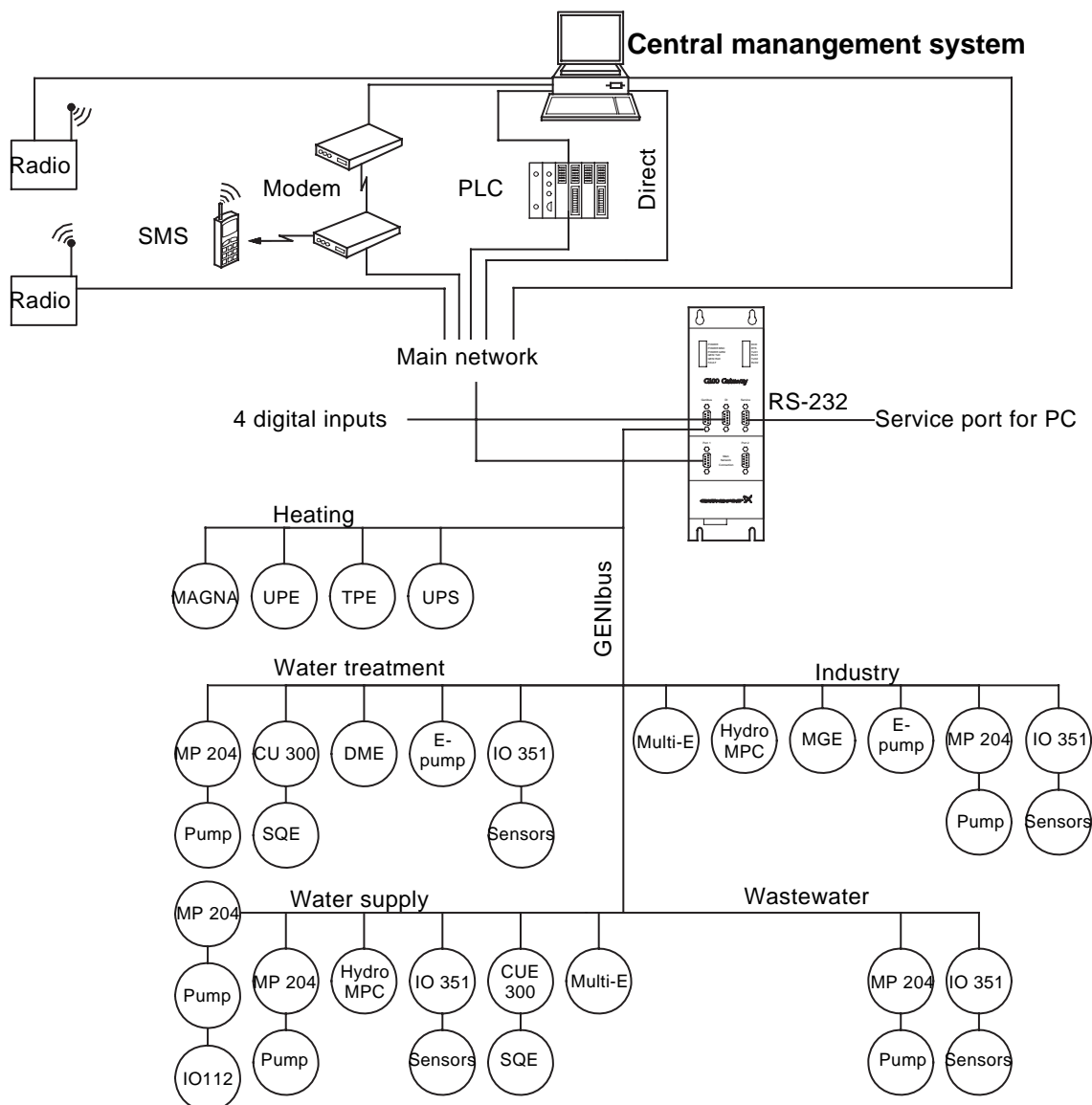

Fig. 40 Examples of G100 applications

TM03 9224 3607

## Product description

The G100 gateway enables communication of operating data, such as measured values and setpoints, between Grundfos products with GENIbus interface and a main network for control and monitoring.

As indicated in the illustration on page 65, the G100 is suitable for use in applications such as water supply, water treatment, wastewater, building automation and industry.

Common to the above applications is that downtime is usually costly, and extra investments are therefore often made to achieve maximum reliability by monitoring selected operating variables.

The day-to-day operation, such as starting and stopping of pumps and changing of setpoints, can also be effected from the main system by communication with the G100. In addition, the G100 can be set up to send event-controlled status indications such as alarms via the SMS to mobile phones, and to make automatic alarm call-backs to a central management system.

## Data logging

Besides the possibility of data communication, the G100 offers logging of up to 350,000 time-stamped data. The logged data can be transmitted to the main system or a PC for further analysis in a spreadsheet or similar program.

For the data logging, the "PC Tool G100 Data Log" software tool is used. The tool is part of the PC Tool G100 package, which is supplied with the G100.

## Other features

- Four digital inputs.
- Stop of all pumps in case of failing communication with the management system (optional).
- Access code for modem communication (optional).
- Alarm log.

## Installation

Installation of the G100 is effected by the system integrator. The G100 is connected to the GENIbus as well as to the main network. All units on the GENIbus can thus be controlled from a central management system on the main network.

The G100 Support Files CD-ROM supplied with the G100 contains examples of programs to be used when the G100 is connected to the various main network systems. Included is also a description of the data points available in Grundfos products with GENIbus interface.

The "PC Tool G100" software tool included can be used for the installation and use of the G100.

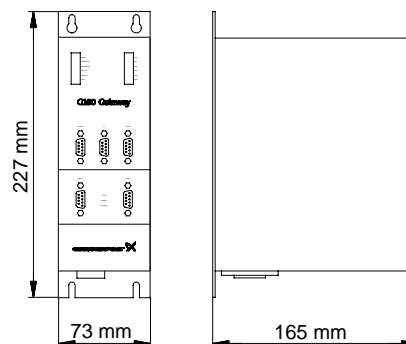

Fig. 41 Dimensional sketch

TM01 0621 1102

## Technical data

### Overview of protocols

Main system	Software protocol
PROFIBUS-DP	DP
Radio	Satt Control COMLI/Modbus
Modem	Satt Control COMLI/Modbus
PLC	Satt Control COMLI/Modbus
GSM mobile phone	SMS, UCP

### Other possible connections

- GENIbus RS-485: Connection of up to 32 units.
- Service port RS-232: For direct connection to a PC or via radio modem.
- Digital inputs: 4.
- Voltage supply: 1 x 110-240 V, 50/60 Hz.
- Ambient temperature: In operation: -20 °C to +60 °C.
- Enclosure class: IP 20.
- Weight: 1.8 kg.

### Accessories

- PC Tool G100 package (supplied with the G100)
- G100 Support Files CD-ROM (supplied with the G100)

### Product numbers

Product	Product number
G100 with PROFIBUS-DP expansion board*	96411135
G100 with Radio/Modem/PLC expansion board*	96411136
G100 Basic Version*	96411137
PC Tool G100 package	96415783

\* CD-ROM with G100 Support Files included.

## SA-SPM control boxes

### Application

SA-SPM control boxes are used as starting units for single-phase, 3-wire motors, types MS 402B and MS 4000.

**SA-SPM 2** is used for single-phase MS 402B motors with a power input lower than or equal to 0.75 kW.

**SA-SPM 3** is used for single-phase MS 402B and MS 4000 motors with a power input higher than or equal to 1.1 kW. SA-SPM 3 incorporates a motorprotective circuit breaker and thus protects the motor against overload.

### Technical data

Enclosure class: IP 42.

Ambient temperature: -20°C to 60°C.

Relative air humidity: Maximum 95 %, normal non-aggressive atmosphere.

### Product numbers

Product number 50 Hz	SA-SPM control box							
	SA-SPM 2		SA-SPM 3		MS 402B		MS 4000	
	1 x 220-230 V	1 x 240 V	0.37 kW	0.55 kW	0.75 kW	1.1 kW	1.5 kW	2.2 kW
82219512	•	•	•					
82219513	•	•		•				
82219514	•	•			•			
82219315	•		•			•		
82219306	•		•				•	
82219307	•		•					•
82249512		•	•	•				
82249513		•	•		•			
82249514		•	•			•		
82249315		•	•				•	
82249306		•	•					•
82249307		•	•					•

# Table of head losses

Submersible pumps  
SP Environmental

## Head losses in ordinary water pipes

Upper figures indicate the velocity of water in m/sec.

Lower figures indicate head loss in metres per 100 metres of straight pipes.

Quantity of water			Head losses in ordinary water pipes																
m <sup>3</sup> /h	Litres/min.	Litres/sec.	Nominal pipe diameter in inches and internal diameter in mm																
			1/2" 15.75	3/4" 21.25	1" 27.00	1 1/4" 35.75	1 1/2" 41.25	2" 52.50	2 1/2" 68.00	3" 80.25	3 1/2" 92.50	4" 105.0	5" 130.0	6" 155.5					
0.6	10	0.16	0.855 9.910	0.470 2.407	0.292 0.784														
0.9	15	0.25	1.282 20.11	0.705 4.862	0.438 1.570	0.249 0.416													
1.2	20	0.33	1.710 33.53	0.940 8.035	0.584 2.588	0.331 0.677	0.249 0.346												
1.5	25	0.42	2.138 49.93	1.174 11.91	0.730 3.834	0.415 1.004	0.312 0.510												
1.8	30	0.50	2.565 69.34	1.409 16.50	0.876 5.277	0.498 1.379	0.374 0.700	0.231 0.223											
2.1	35	0.58	2.993 91.54	1.644 21.75	1.022 6.949	0.581 1.811	0.436 0.914	0.269 0.291											
2.4	40	0.67		1.879 27.66	1.168 8.820	0.664 2.290	0.499 1.160	0.308 0.368											
3.0	50	0.83		2.349 41.40	1.460 13.14	0.830 3.403	0.623 1.719	0.385 0.544	0.229 0.159										
3.6	60	1.00		2.819 57.74	1.751 18.28	0.996 4.718	0.748 2.375	0.462 0.751	0.275 0.218										
4.2	70	1.12		3.288 76.49	2.043 24.18	1.162 6.231	0.873 3.132	0.539 0.988	0.321 0.287	0.231 0.131									
4.8	80	1.33			2.335 30.87	1.328 7.940	0.997 3.988	0.616 1.254	0.367 0.363	0.263 6.164									
5.4	90	1.50			2.627 38.30	1.494 9.828	1.122 4.927	0.693 1.551	0.413 0.449	0.269 0.203									
6.0	100	1.67			2.919 46.49	1.660 11.90	1.247 5.972	0.770 1.875	0.459 0.542	0.329 0.244	0.248 0.124								
7.5	125	2.08			3.649 70.41	2.075 17.93	1.558 8.967	0.962 2.802	0.574 0.809	0.412 0.365	0.310 0.185	0.241 0.101							
9.0	150	2.50				2.490 25.11	1.870 12.53	1.154 3.903	0.668 1.124	0.494 0.506	0.372 0.256	0.289 0.140							
10.5	175	2.92				2.904 33.32	2.182 16.66	1.347 5.179	0.803 1.488	0.576 0.670	0.434 0.338	0.337 0.184							
12	200	3.33				3.319 42.75	2.493 21.36	1.539 6.624	0.918 1.901	0.659 0.855	0.496 0.431	0.385 0.234	0.251 0.084						
15	250	4.17				4.149 64.86	3.117 32.32	1.924 10.03	1.147 2.860	0.823 1.282	0.620 0.646	0.481 0.350	0.314 0.126						
18	300	5.00					3.740 45.52	2.309 14.04	1.377 4.009	0.988 1.792	0.744 0.903	0.577 0.488	0.377 0.175	0.263 0.074					
24	400	6.67					4.987 78.17	3.078 24.04	1.836 6.828	1.317 3.053	0.992 1.530	0.770 0.829	0.502 0.294	0.351 0.124					
30	500	8.33						3.848 36.71	2.295 10.40	1.647 4.622	1.240 2.315	0.962 1.254	0.628 0.445	0.439 0.187					
36	600	10.0						4.618 51.84	2.753 14.62	1.976 6.505	1.488 3.261	1.155 1.757	0.753 0.623	0.526 0.260					
42	700	11.7							3.212 19.52	2.306 8.693	1.736 4.356	1.347 2.345	0.879 0.831	0.614 0.347					
48	800	13.3							3.671 25.20	2.635 11.18	1.984 5.582	1.540 3.009	1.005 1.066	0.702 0.445					
54	900	15.0							4.130 31.51	2.964 13.97	2.232 6.983	1.732 3.762	1.130 1.328	0.790 0.555					
60	1000	16.7							4.589 38.43	3.294 17.06	2.480 8.521	1.925 4.595	1.256 1.616	0.877 0.674					
75	1250	20.8								4.117 26.10	3.100 13.00	2.406 7.010	1.570 2.458	1.097 1.027					
90	1500	25.0								4.941 36.97	3.720 18.42	2.887 9.892	1.883 3.468	1.316 1.444					
105	1750	29.2									4.340 24.76	3.368 13.30	2.197 4.665	1.535 1.934					
120	2000	33.3									4.960 31.94	3.850 17.16	2.511 5.995	1.754 2.496					
150	2500	41.7										4.812 26.26	3.139 9.216	2.193 3.807					
180	3000	50.0											3.767 13.05	2.632 5.417					
240	4000	66.7												5.023 22.72	3.509 8.926				
300	5000	83.3													4.386 14.42				
90° bends slide valves			1.0	1.0	1.1	1.2	1.3	1.4	1.5	1.6	1.6	1.7	2.0	2.5					
T-pieces, non-return valves			4.0	4.0	4.0	5.0	5.0	5.0	6.0	6.0	6.0	7.0	8.0	9.0					

The table is calculated in accordance with H. Lang's new formula  $a = 0.02$  and for a water temperature of 10 °C.

The head loss in bends, slide valves, T-pieces and non-return valves is equivalent to the metres of straight pipes stated in the last two lines of the table. To find the head loss in foot valves multiply the loss in T-pieces by two.

# Table of head losses

Submersible pumps  
SP Environmental

## Head losses in plastic pipes

Upper figures indicate the water velocity in m/sec.

Lower figures indicate head loss in metres per 100 metres of straight pipes.

Quantity of water			PELM/PEH PN 10															
m <sup>3</sup> /h	Litres/min.	Litres/sec.	PELM					PEH										
			25 20.4	32 26.2	40 32.6	50 40.8	63 51.4	75 61.4	90 73.6	110 90.0	125 102.2	140 114.6	160 130.8	180 147.2				
0.6	10	0.16	0.49 1.8	0.30 0.66	0.19 0.27	0.12 0.085												
0.9	15	0.25	0.76 4.0	0.46 1.14	0.3 0.6	0.19 0.18	0.12 0.63											
1.2	20	0.33	1.0 6.4	0.61 2.2	0.39 0.9	0.25 0.28	0.16 0.11											
1.5	25	0.42	1.3 10.0	0.78 3.5	0.5 1.4	0.32 0.43	0.2 0.17	0.14 0.074										
1.8	30	0.50	1.53 13.0	0.93 4.6	0.6 1.9	0.38 0.57	0.24 0.22	0.17 0.092										
2.1	35	0.58	1.77 16.0	1.08 6.0	0.69 2.0	0.44 0.70	0.28 0.27	0.2 0.12										
2.4	40	0.67	2.05 22.0	1.24 7.5	0.80 3.3	0.51 0.93	0.32 0.35	0.23 0.16	0.16 0.063									
3.0	50	0.83	2.54 37.0	1.54 11.0	0.99 4.8	0.63 1.40	0.4 0.50	0.28 0.22	0.2 0.09									
3.6	60	1.00	3.06 43.0	1.85 15.0	1.2 6.5	0.76 1.90	0.48 0.70	0.34 0.32	0.24 0.13	0.16 0.050								
4.2	70	1.12	3.43 50.0	2.08 18.0	1.34 8.0	0.86 2.50	0.54 0.83	0.38 0.38	0.26 0.17	0.18 0.068								
4.8	80	1.33		2.47 25.0	1.59 10.5	1.02 3.00	0.64 1.20	0.45 0.50	0.31 0.22	0.2 0.084								
5.4	90	1.50		2.78 30.0	1.8 12.0	1.15 3.50	0.72 1.30	0.51 0.57	0.35 0.26	0.24 0.092	0.18 0.05							
6.0	100	1.67		3.1 39.0	2.0 16.0	1.28 4.6	0.8 1.80	0.56 0.73	0.39 0.30	0.26 0.12	0.2 0.07							
7.5	125	2.08		3.86 50.0	2.49 24.0	1.59 6.6	1.00 2.50	0.70 1.10	0.49 0.50	0.33 0.18	0.25 0.10	0.20 0.055						
9.0	150	2.50			3.00 33.0	1.91 8.6	1.20 3.5	0.84 1.40	0.59 0.63	0.39 0.24	0.30 0.13	0.24 0.075						
10.5	175	2.92			3.5 38.0	2.23 11.0	1.41 4.3	0.99 1.80	0.69 0.78	0.46 0.30	0.36 0.18	0.28 0.09						
12	200	3.33			3.99 50.0	2.55 14.0	1.60 5.5	1.12 2.40	0.78 1.0	0.52 0.40	0.41 0.22	0.32 0.12	0.25 0.065					
15	250	4.17				3.19 21.0	2.01 8.0	1.41 3.70	0.98 1.50	0.66 0.57	0.51 0.34	0.40 0.18	0.31 0.105	0.25 0.06				
18	300	5.00				3.82 28.0	2.41 10.5	1.69 4.60	1.18 1.95	0.78 0.77	0.61 0.45	0.48 0.25	0.37 0.13	0.29 0.085				
24	400	6.67					3.21 19.0	2.25 8.0	1.57 3.60	1.05 1.40	0.81 0.78	0.65 0.44	0.50 0.23	0.39 0.15				
30	500	8.33					4.01 28.0	2.81 11.5	1.96 5.0	1.31 2.0	1.02 1.20	0.81 0.63	0.62 0.33	0.49 0.21				
36	600	10.0					4.82 37.0	3.38 15.0	2.35 6.6	1.57 2.60	1.22 1.50	0.97 0.82	0.74 0.45	0.59 0.28				
42	700	11.7					5.64 47.0	3.95 24.0	2.75 8.0	1.84 3.50	1.43 1.90	1.13 1.10	0.87 0.60	0.69 0.40				
48	800	13.3						4.49 26.0	3.13 11.0	2.09 4.5	1.62 2.60	1.29 1.40	0.99 0.81	0.78 0.48				
54	900	15.0						5.07 33.0	3.53 13.5	2.36 5.5	1.83 3.20	1.45 1.70	1.12 0.95	0.08 0.58				
60	1000	16.7						5.64 40.0	3.93 16.0	2.63 6.7	2.04 3.90	1.62 2.2	1.24 1.2	0.96 0.75				
75	1250	20.8							4.89 25.0	3.27 9.0	2.54 5.0	2.02 3.0	1.55 1.6	1.22 0.95				
90	1500	25.0							5.88 33.0	3.93 13.0	3.05 8.0	2.42 4.1	1.86 2.3	1.47 1.40				
105	1750	29.2							6.86 44.0	4.59 17.5	3.56 9.7	2.83 5.7	2.17 3.2	1.72 1.9				
120	2000	33.3								5.23 23.0	4.06 13.0	3.23 7.0	2.48 4.0	1.96 2.4				
150	2500	41.7								6.55 34.0	5.08 18.0	4.04 10.5	3.10 6.0	2.45 3.5				
180	3000	50.0								7.86 45.0	6.1 27.0	4.85 14.0	3.72 7.6	2.94 4.4				
240	4000	66.7									8.13 43.0	6.47 24.0	4.96 13.0	3.92 7.5				
300	5000	83.3										8.08 33.0	6.2 18.0	4.89 11.0				

The table is based on a nomogram.  
Roughness: K = 0.01 mm.  
Water temperature: t = 10 °C.

## Order data

### Product numbers

The pump is supplied complete with motor and cable guard fitted, but without the cable with plug, which must be ordered separately.

#### SP 3A-NE, 1 x 230 V

Pump type	Motor		Product number
	Type	P <sub>2</sub> [kW]	
SP 3A-6 NE			10222106
SP 3A-9 NE			10222109
SP 3A-12 NE			10222112
SP 3A-15 NE	MS 4000 RE	2.2	10222115
SP 3A-18 NE			10222118
SP 3A-22 NE			10222122
SP 3A-25 NE			10222125
SP 3A-29 NE			10222129

#### SP 5A-NE, 1 x 230 V

Pump type	Motor		Product number
	Type	P <sub>2</sub> [kW]	
SP 5A-4 NE			05222104
SP 5A-6 NE			05222106
SP 5A-8 NE			05222108
SP 5A-12 NE	MS 4000 RE	2.2	05222112
SP 5A-17 NE			05222117
SP 5A-21 NE			05222121
SP 5A-25 NE			05222125
SP 5A-33 NE			05222133

#### SP 8A-NE, 1 x 230 V

Pump type	Motor		Product number
	Type	P <sub>2</sub> [kW]	
SP 8A-5 NE			11222105
SP 8A-7 NE			11222107
SP 8A-10 NE	MS 4000 RE	2.2	11222110
SP 8A-12 NE			11222112
SP 8A-15 NE			11222115

#### SP 17-NE, 1 x 230 V

Pump type	Motor		Product number
	Type	P <sub>2</sub> [kW]	
SP 17-1 NE			12C92101
SP 17-2 NE	MS 4000 RE	2.2	12C92102
SP 17-3 NE			12C92103
SP 17-4 NE			12C92104

### Cables

Motor cables complete with one motor plug.

Cable length [m]	Product number
10	00795667
20	00795668
30	00795669
40	00795670
50	00795671
60	00795672
70	00795673
80	00795674
90	00795675
100	00795676
120	96426909

#### SP 3A-NE, 3 x 400 V

Pump type	Motor		Product number
	Type	P <sub>2</sub> [kW]	
SP 3A-6 NE			10221906
SP 3A-9 NE		0.75	10221909
SP 3A-12 NE			10221912
SP 3A-15 NE	MS 4000 RE	1.1	10221915
SP 3A-18 NE			10221918
SP 3A-22 NE			10221922
SP 3A-25 NE			10221925
SP 3A-29 NE			10221929

#### SP 5A-NE, 3 x 400 V

Pump type	Motor		Product number
	Type	P <sub>2</sub> [kW]	
SP 5A-4 NE			05221904
SP 5A-6 NE		0.75	05221906
SP 5A-8 NE			05221908
SP 5A-12 NE	MS 4000 RE	1.1	05221912
SP 5A-17 NE			05221917
SP 5A-21 NE			05221921
SP 5A-25 NE			05221925
SP 5A-33 NE			05221933

#### SP 8A-NE, 3 x 400 V

Pump type	Motor		Product number
	Type	P <sub>2</sub> [kW]	
SP 8A-5 NE		0.75	11221905
SP 8A-7 NE		1.1	11221907
SP 8A-10 NE		1.5	11221910
SP 8A-12 NE	MS 4000 RE	2.2	11221912
SP 8A-15 NE			11221915
SP 8A-18 NE			11221918
SP 8A-21 NE			11221921
SP 8A-25 NE			11221925

#### SP 17-NE, 3 x 400 V

Pump type	Motor		Product number
	Type	P <sub>2</sub> [kW]	
SP 17-1 NE		0.75	12C91901
SP 17-2 NE		1.1	12C91902
SP 17-3 NE		2.2	12C91903
SP 17-4 NE			12C91904
SP 17-5 NE	MS 4000 RE	3.0	12C91905
SP 17-6 NE			12C91906
SP 17-7 NE			12C91907
SP 17-8 NE			12C91908
SP 17-9 NE			12C91909
SP 17-10 NE		5.5	12C91910

## Resistance list

A number of typical liquids are listed below. The list is to be used as a guide only.

### Legend

– = Not applicable.

### Pure saturated acids, not specified

	Liquid	Chemical formula	Concentration	Max. liquid temperature		
				SP(A)-NE	SQE-NE	MP 1
Acids	Acetic acid	CH <sub>3</sub> COOH	15 %	30 °C	30 °C	–
	Benzoic acid	C <sub>6</sub> H <sub>5</sub> COOH	100 %	20 °C	20 °C	20 °C
	Boric acid	H <sub>3</sub> BO <sub>3</sub>	30 %	40 °C	40 °C	40 °C
	Chromic acid	H <sub>2</sub> CrO <sub>4</sub>	20 %	20 °C	–	–
	Citric acid	HOC(CH <sub>2</sub> CO <sub>2</sub> H) <sub>2</sub> COOH	40 %	40 °C	40 °C	40 °C
	Formic acid	HCOOH	100 %	20 °C	–	20 °C
	Hydrochloric acid	HCl	10 %	–	–	–
	Hydrogen flouride	HF	1 %	20 °C	20 °C	20 °C
	Lactic acid	CH <sub>3</sub> CH(OH)COOH	100 %	20 °C	–	20 °C
	Linoleic acid	C <sub>17</sub> H <sub>31</sub> COOH	100 %	20 °C	–	20 °C
	Nitric acid	HNO <sub>3</sub>	10 %	–	–	–
	Oxalic acid	(COOH) <sub>2</sub>	15 %	40 °C	40 °C	40 °C
	Phosphoric acid	H <sub>3</sub> PO <sub>4</sub>	30 %	20 °C	20 °C	20 °C
	Salicylic acid	C <sub>6</sub> H <sub>4</sub> (OH)COOH	40 %	0 °C	40 °C	40 °C
	Sulfuric acid	H <sub>2</sub> SO <sub>4</sub>	5 %	20 °C	10 °C	20 °C

### Neutral liquids

	Liquid	Chemical formula	Concentration	Max. liquid temperature		
				SP(A)-NE	SQE-NE	MP 1
	De-ionised water	H <sub>2</sub> O	-	40 °C	40 °C	40 °C

### Alkaline liquids

	Liquid	Chemical formula	Concentration	Max. liquid temperature		
				SP(A)-NE	SQE-NE	MP 1
Alkalis	Ammonia	NH <sub>3</sub>	25 %	–	–	–
	Ammonium hydroxide	NH <sub>4</sub> OH	60 %	20 °C	–	–
	Barium hydroxide	Ba(OH) <sub>2</sub>	10 %	40 °C	40 °C	40 °C
	Calcium hydroxide	Ca(OH) <sub>2</sub>	10 %	20 °C	–	20 °C
	Calcium hypochlorite	Ca(ClO) <sub>2</sub>	10 %	–	–	–
	Potassium hydroxide	KOH	1 %	–	–	–
	Sodium hydroxide	NaOH	1 %	20 °C	20 °C	20 °C
	Sodium hypochlorite	NaOCl	10 %	–	–	–

## Salts in aqueous solutions

	Liquid	Chemical formula	Concentration	Max. liquid temperature		
				SP(A)-NE	SQE-NE	MP 1
Acetate	Sodium acetate	CH <sub>3</sub> COONa	1 %	20 °C	20 °C	20 °C
Borate	Sodium tetra borate	Na <sub>2</sub> B <sub>4</sub> O <sub>7</sub>	1 %	40 °C	40 °C	40 °C
Bromate	Bromate	BrO <sub>3</sub> <sup>-</sup>	1 %	40 °C	40 °C	40 °C
Carbonates	Carbonates	CO <sub>3</sub> <sup>2-</sup>	1 %	40 °C	40 °C	40 °C
	Potassium bicarbonate	KHCO <sub>3</sub>	10 %	40 °C	40 °C	40 °C
	Potassium carbonate	K <sub>2</sub> CO <sub>3</sub>	20 %	40 °C	40 °C	40 °C
	Sodium carbonate	Na <sub>2</sub> CO <sub>3</sub>	20 %	40 °C	40 °C	40 °C
	Sodium hydrogencarbonate	NaHCO <sub>3</sub>	10 %	40 °C	40 °C	40 °C
Chlorates	Sodium chlorate	NaClO <sub>3</sub>	20 %	20 °C	-	-
	Sodium perchlorate	NaClO <sub>4</sub>	30 %	40 °C	-	-
Chlorides	Aluminium chloride	AlCl <sub>3</sub>	0.1 %	-	-	-
	Ferric chloride	FeCl <sub>3</sub>	0.1 %	-	-	-
	Ferrous chloride	FeCl <sub>2</sub>	1 %	20 °C	20 °C	20 °C
	Sodium chloride	NaCl	1000 ppm (0.1 %)	20 °C	20 °C	20 °C
Chromates	Chromates	CrO <sub>4</sub> <sup>2-</sup>	1 %	40 °C	40 °C	40 °C
	Potassium dichromate	K <sub>2</sub> Cr <sub>2</sub> O <sub>7</sub>	20 %	20 °C	-	-
Hypochlorite	Hypochlorite	ClO <sup>-</sup>	<0.1 %	20 °C	-	-
Iodide	Iodides	I <sup>-</sup>	<0.5 %	20 °C	20 °C	20 °C
Nitrates	Ammonium nitrate	NH <sub>4</sub> NO <sub>3</sub>	20 %	40 °C	40 °C	40 °C
	Barium nitrate	Ba(NO <sub>3</sub> ) <sub>2</sub>	10 %	40 °C	40 °C	40 °C
	Nitrate	NO <sub>3</sub> <sup>-</sup>	1 %	40 °C	40 °C	40 °C
	Silver nitrate	AgNO <sub>3</sub>	20 %	40 °C	40 °C	40 °C
	Sodium nitrate	NaNO <sub>3</sub>	20 %	40 °C	0 °C	40 °C
Nitrites	Nitrite	NO <sub>2</sub> <sup>-</sup>	1 %	40 °C	40 °C	40 °C
	Sodium nitrite	NaNO <sub>2</sub>	20 %	40 °C	40 °C	40 °C
Peroxides	Peroxides	O <sub>2</sub> <sup>2-</sup>	10 %	20 °C	-	-
	Potassium permanganate	KMnO <sub>4</sub>	10 %	40 °C	20 °C	-
Phosphate	Sodium phosphate	Na <sub>3</sub> PO <sub>4</sub>	1 %	40 °C	40 °C	40 °C
Silicate	Sodium metasilicate	Na <sub>2</sub> SiO <sub>3</sub>	10 %	40 °C	40 °C	40 °C
Sulfates	Ammonium sulfate	(NH <sub>4</sub> ) <sub>2</sub> SO <sub>4</sub>	20 %	40 °C	40 °C	40 °C
	Copper sulfate	CuSO <sub>4</sub>	20 %	40 °C	40 °C	40 °C
	Ferric sulfate	Fe <sub>2</sub> (SO <sub>4</sub> ) <sub>3</sub>	10 %	40 °C	40 °C	40 °C
	Ferrous sulfate	FeSO <sub>4</sub>	10 %	40 °C	40 °C	40 °C
	Magnesium sulfate	MgSO <sub>4</sub>	20 %	40 °C	40 °C	40 °C
	Sodium hydrogen sulfate	NaHSO <sub>4</sub>	10 %	20 °C	40 °C	20 °C
	Sodium sulfate	Na <sub>2</sub> SO <sub>4</sub>	10 %	20 °C	40 °C	20 °C
	Sulfate	SO <sub>4</sub> <sup>2-</sup>	1 %	40 °C	40 °C	40 °C
Sulfites	Sodium hydrogen sulfite	NaHSO <sub>3</sub>	10 %	20 °C	20 °C	20 °C
	Sodium sulfite	Na <sub>2</sub> SO <sub>3</sub>	20 %	20 °C	20 °C	20 °C
	Sulfite	SO <sub>3</sub> <sup>2-</sup>	1 %	40 °C	40 °C	40 °C



## Gasses, saturated solutions

	Liquid	Chemical formula	Concentration	Max. liquid temperature		
				SP(A)-NE	SQE-NE	MP 1
Gasses	Bromine	Br <sub>2</sub>	5 ppm	–	–	–
	Carbon dioxide	CO <sub>2</sub>	5 ppm	40 °C	40 °C	40 °C
	Chlorine	Cl <sub>2</sub>	5 ppm	40 °C	40 °C	40 °C
	Hydrogen sulfide	H <sub>2</sub> S	5 ppm	–	–	–
	Iodine	I <sub>2</sub>	5 ppm	–	–	–
	Ozone	O <sub>3</sub>	5 ppm	40 °C	40 °C	–
	Sulfur dioxide	SO <sub>2</sub>	5 ppm	40 °C	40 °C	40 °C

## Organic liquids

### Homopolar liquids, oils

	Liquid	Chemical formula	Concentration	Max. liquid temperature		
				SP(A)-NE	SQE-NE	MP 1
Mineral oils	ASTM1		100 %	40 °C	40 °C	40 °C
	ASTM3		100 %	40 °C	40 °C	40 °C
Silicone	Silicone oil		100 %	40 °C	40 °C	40 °C
Vegetable/animal oils	Corn oil		100 %	20 °C	20 °C	20 °C
	Olive oil		100 %	20 °C	20 °C	20 °C
	Peanut oil		100 %	–	–	–
	Rape seed oil		100 %	20 °C	20 °C	20 °C
	Soya bean oil		100 %	20 °C	20 °C	20 °C

## Organic liquids

### Homopolar liquids, solutions/fuels

	Liquid	Chemical formula	Concentration	Max. liquid temperature		
				SP(A)-NE	SQE-NE	MP 1
Alicyclic organic liquids	Cyclohexane	C <sub>6</sub> H <sub>12</sub>	1 %	40 °C	40 °C	40 °C
	Naphtalene	C <sub>10</sub> H <sub>8</sub>	1 %	–	–	–
Aliphatic	Hexane	C <sub>6</sub> H <sub>14</sub>	1 %	40 °C	40 °C	40 °C
	Octane	C <sub>8</sub> H <sub>18</sub>	1 %	40 °C	40 °C	40 °C
	Pentane	C <sub>5</sub> H <sub>12</sub>	1 %	40 °C	40 °C	40 °C
Compounds	Diesel oil		1 %	40 °C	40 °C	40 °C
	Jet fuel		1 %	–	–	–
	Motor oil		1 %	20 °C	20 °C	20 °C
	Paraffin oil		1 %	20 °C	20 °C	20 °C
	Petroleum		1 %	40 °C	40 °C	40 °C
	Tar oil		1 %	–	–	–
Turpentine		1 %	40 °C	40 °C	40 °C	

## Organic liquids

### Homopolar liquids, solutions/fuels

	Liquid	Chemical formula	Concentration	Max. liquid temperature		
				SP(A)-NE	SQE-NE	MP 1
Aromatic organic liquids	Benzene	C <sub>6</sub> H <sub>6</sub>	1 %	–	–	–
	Diphenyl	C <sub>6</sub> H <sub>5</sub> C <sub>6</sub> H <sub>5</sub>	1 %	25 °C	25 °C	25 °C
	Toluene	C <sub>6</sub> H <sub>5</sub> CH <sub>3</sub>	1 %	40 °C	40 °C	–
	Xylene	C <sub>6</sub> H <sub>4</sub> (CH <sub>3</sub> ) <sub>2</sub>	1 %	40 °C	40 °C	–

## Organic liquids

### Polar liquids, chlorine-containing

	Liquid	Chemical formula	Concentration	Max. liquid temperature		
				SP(A)-NE	SQE-NE	MP 1
Polar solutions	Chloroform	CHCl <sub>3</sub>	1 %	40 °C	25 °C	25 °C
	Methylene chloride	CH <sub>2</sub> Cl <sub>2</sub>	1 %	–	–	–
	Perchloroethylene	C <sub>2</sub> Cl <sub>4</sub>	1 %	40 °C	25 °C	25 °C
	Tetrachloroethane	C <sub>2</sub> H <sub>2</sub> Cl <sub>4</sub>	25 %	–	–	–
	Tetrachloroethylene	C <sub>2</sub> Cl <sub>4</sub>	25 %	–	–	–
	Trichlorethylene	C <sub>2</sub> HCl <sub>3</sub>	25 %	25 °C	–	25 °C

## Organic liquids

### Polar liquids, oxygenous

	Liquid	Chemical formula	Concentration	Max. liquid temperature		
				SP(A)-NE	SQE-NE	MP 1
Acids, low molecular	Acetic acid	CH <sub>3</sub> COOH	100 %	–	–	–
	Formic acid	HCOOH	100 %	–	–	–
Alcohols	Butanol (butyl alcohol)	C <sub>4</sub> H <sub>9</sub> OH	100 %	40 °C	40 °C	40 °C
	Ethanol (ethyl alcohol)	C <sub>2</sub> H <sub>5</sub> OH	100 %	–	–	–
	Methanol (methyl alcohol)	CH <sub>3</sub> OH	100 %	–	–	–
	Phenol	C <sub>6</sub> H <sub>5</sub> OH	100 %	–	–	–
	Propanol	C <sub>3</sub> H <sub>7</sub> OH	100 %	20 °C	20 °C	20 °C
Aldehydes	Benzaldehyde	C <sub>6</sub> H <sub>5</sub> CHO	100 %	–	–	–
	Formalin (formaldehyde)	CH <sub>2</sub> O	30 %	–	–	–
Cyclic ether	Dioxan	C <sub>4</sub> H <sub>8</sub> O <sub>2</sub>	100 %	–	–	–
Esters	Ethyl acetate	CH <sub>3</sub> COOC <sub>2</sub> H <sub>5</sub>	100 %	–	–	–
	Isobutyl acetate	C <sub>6</sub> H <sub>12</sub> O <sub>2</sub>	100 %	–	–	–
Ethers	Cellosolve	C <sub>2</sub> H <sub>5</sub> OCH <sub>2</sub> CH <sub>2</sub> OH	100 %	–	–	–
	Diethyl ether	C <sub>2</sub> H <sub>5</sub> OC <sub>2</sub> H <sub>5</sub>	100 %	–	–	–
	Methyl ethyl ether	C <sub>3</sub> H <sub>8</sub> O	100 %	–	–	–
Glycols	Ethylene glycol	HOCH <sub>2</sub> CH <sub>2</sub> OH	100 %	40 °C	25 °C	40 °C
	Glycerine (glycerol)	OHCH <sub>2</sub> CH(OH)CH <sub>2</sub> OH	100 %	40 °C	40 °C	40 °C
	Propylene glycol	CH <sub>3</sub> CH(OH)CH <sub>2</sub> OH	100 %	20 °C	20 °C	20 °C
Ketones	Acetone	CH <sub>3</sub> COCH <sub>3</sub>	100 %	–	–	–
	Acetophenone	C <sub>6</sub> H <sub>5</sub> COCH <sub>3</sub>	100 %	–	–	–
	Cyclohexanone	C <sub>6</sub> H <sub>10</sub> O	100 %	–	–	–
	MEK (methyl ethyl ketone)	C <sub>4</sub> H <sub>8</sub> O	100 %	–	–	–
	MIBK (methyl isobutyl ketone)	C <sub>6</sub> H <sub>12</sub> O	100 %	–	–	–

## Organic liquids

### Polar liquids, P-containing

	Liquid	Chemical formula	Concentration	Max. liquid temperature		
				SP(A)-NE	SQE-NE	MP 1
Phosphate ester	Skydrol 500		100 %	–	–	–
	Skydrol 7000		100 %	–	–	–
	Tributyl phosphate	(C <sub>4</sub> H <sub>9</sub> ) <sub>3</sub> PO <sub>4</sub>	100 %	–	–	–

## Polar liquids, N-containing

	Liquid	Chemical formula	Concentration	Max. liquid temperature		
				SP(A)-NE	SQE-NE	MP 1
Additives for cooling lubricating liquids	NACE A (water)			-	-	-
	NACE B (oil)			-	-	-
Amides	Acetamide	C <sub>2</sub> H <sub>5</sub> NO	100 %	-	-	-
	Formamide	CH <sub>3</sub> NO	100 %	-	-	-
Amines	Aniline	C <sub>6</sub> H <sub>5</sub> NH <sub>2</sub>	100 %	40 °C	20 °C	40 °C
	Dimethylamine	(CH <sub>3</sub> ) <sub>2</sub> NH	100 %	-	-	-
	Ethylamine	C <sub>2</sub> H <sub>5</sub> NH <sub>2</sub>	100 %	-	-	-
	Hydrazine	H <sub>2</sub> NNH <sub>2</sub>	100 %	-	-	-
	Tert-butylamine	(CH <sub>3</sub> ) <sub>3</sub> CNH <sub>2</sub>	100 %	-	-	-
	Triethanolamine	(HOC <sub>2</sub> H <sub>4</sub> ) <sub>3</sub> N	100 %	-	-	-
Cyclic organic liquid	Pyridine	C <sub>5</sub> H <sub>5</sub> N	100 %	-	-	-

## Polar liquids, S-containing

	Liquid	Chemical formula	Concentration	Max. liquid temperature		
				SP(A)-NE	SQE-NE	MP 1
Certain S-containing additives	Corrosion inhibitors			-	-	-
EP additives	Friction improving bodies			-	-	-

## Aqueous solutions

	Liquid	Chemical formula	Concentration	Max. liquid temperature		
				SP(A)-NE	SQE-NE	MP 1
Acetates	Copper acetate	(CH <sub>3</sub> COO) <sub>2</sub> Cu	100 %	-	-	-
	Sodium acetate	CH <sub>3</sub> COONa	100 %	-	-	-
Acids	Ascorbic acid	C <sub>6</sub> H <sub>8</sub> O <sub>6</sub>	100 %	40 °C	40 °C	40 °C
	Benzoic acid	C <sub>6</sub> H <sub>5</sub> COOH	100 %	40 °C	20 °C	40 °C
	Citric acid	C <sub>6</sub> H <sub>8</sub> O <sub>7</sub>	40 %	40 °C	40 °C	40 °C
Formates	Sodium formate	HCOONa	100 %	-	-	-
Glycols	Glycol-based brake fluids			-	-	-
Salts of organic amines	Tetramethylammonium chloride	C <sub>4</sub> H <sub>12</sub> CIN	100 %	-	-	-

## WebCAPS

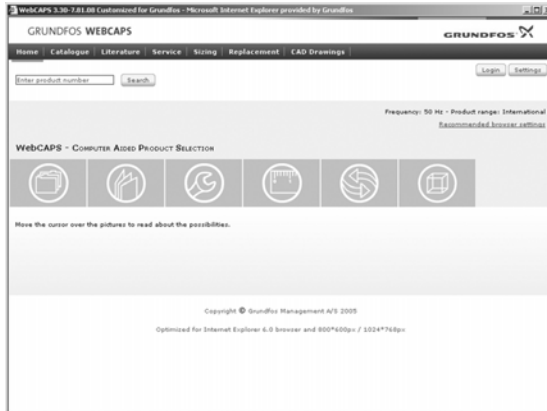

WebCAPS is a **Web**-based **Computer Aided Product Selection** program available on [www.grundfos.com](http://www.grundfos.com).

WebCAPS contains detailed information on more than 185,000 Grundfos products in more than 20 languages.

In WebCAPS, all information is divided into 6 sections:

- Catalogue
- Literature
- Service
- Sizing
- Replacement
- CAD drawings.

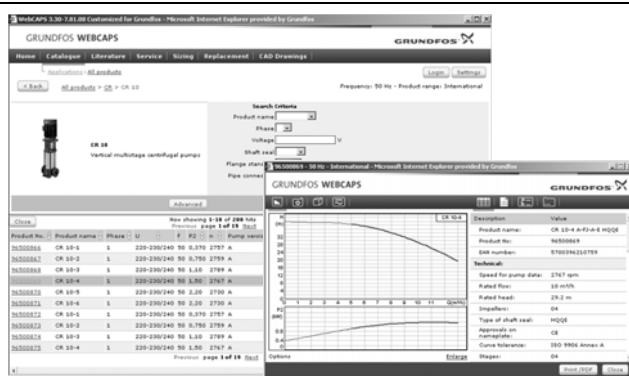

### Catalogue

This section is based on fields of application and pump types, and contains

- technical data
- curves (QH, Eta, P1, P2, etc) which can be adapted to the density and viscosity of the pumped liquid and show the number of pumps in operation
- product photos
- dimensional drawings
- wiring diagrams
- quotation texts, etc.

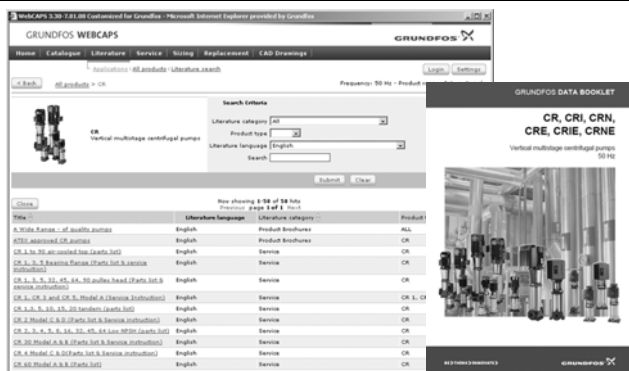

### Literature

In this section you can access all the latest documents of a given pump, such as

- data booklets
- installation and operating instructions
- service documentation, such as Service kit catalogue and Service kit instructions
- quick guides
- product brochures.

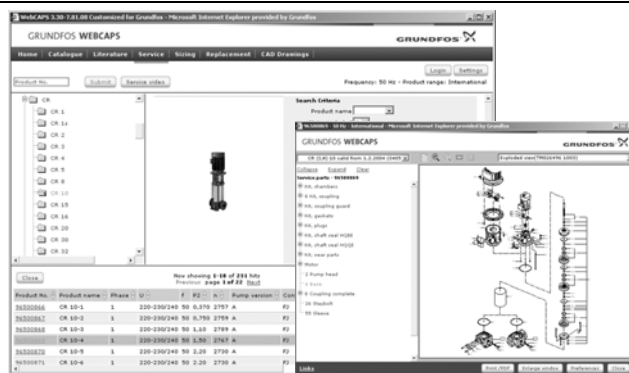

### Service

This section contains an easy-to-use interactive service catalogue. Here you can find and identify service parts of both existing and discontinued Grundfos pumps.

Furthermore, this section contains service videos showing you how to replace service parts.



## Sizing

This section is based on different fields of application and installation examples, and gives easy step-by-step instructions in how to

- select the most suitable and efficient pump for your installation
- carry out advanced calculations based on energy consumption, payback periods, load profiles, life cycle costs, etc.
- analyse your selected pump via the built-in life cycle cost tool
- determine the flow velocity in wastewater applications, etc.



## Replacement

In this section you find a guide to selecting and comparing replacement data of an installed pump in order to replace the pump with a more efficient Grundfos pump. The section contains replacement data of a wide range of pumps produced by other manufacturers than Grundfos.

Based on an easy step-by-step guide, you can compare Grundfos pumps with the one you have installed on your site. When you have specified the installed pump, the guide will suggest a number of Grundfos pumps which can improve both comfort and efficiency.

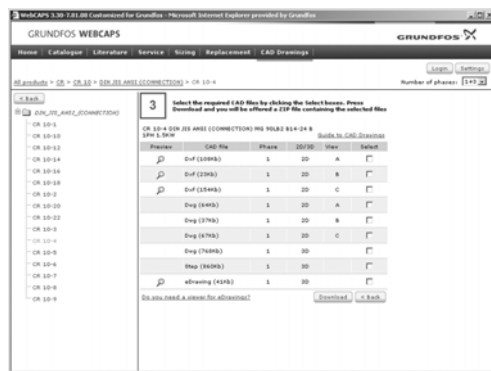

## CAD drawings

In this section it is possible to download 2-dimensional (2D) and 3-dimensional (3D) CAD drawings of most Grundfos pumps.

These formats are available in WebCAPS:

- 2-dimensional drawings:
- .dxf, wireframe drawings
  - .dwg, wireframe drawings.
- 3-dimensional drawings:
- .dwg, wireframe drawings (without surfaces)
  - .stp, solid drawings (with surfaces)
  - .eprt, E-drawings.

## WinCAPS



Fig. 42 WinCAPS CD-ROM

WinCAPS is a **Windows-based Computer Aided Product Selection** program containing detailed information on more than 185,000 Grundfos products in more than 20 languages.

The program contains the same features and functions as WebCAPS, but is an ideal solution if no Internet connection is available.

WinCAPS is available on CD-ROM and updated once a year.





<b>V7121578</b> 0708	<b>GB</b>
Repl. V7121578 0205	

Subject to alterations.