

Swing Check Valve

SISTO-RSK/RSKS

PN 16 / DN 25-300

Zero maintenance
Soft-seated
With or without lining
Flanged ends

Type Series Booklet



SISTO

Legal information/Copyright

Type Series Booklet SISTO-RSK/RSKS

All rights reserved. The contents provided herein must neither be distributed, copied, reproduced, edited or processed for any other purpose, nor otherwise transmitted, published or made available to a third party without the manufacturer's express written consent.

Subject to technical modification without prior notice.

© SISTO Armaturen S.A., Echternach, Luxemburg 18.06.2013

Check Valves and Strainers

Swing Check Valves

SISTO-RSK/RSKS



Main applications

- Mining
- Irrigation systems
- Chemical industry
- Disposal
- Fire-fighting systems
- Domestic water supply
- Nuclear power stations
- Sewage treatment plants
- Fossil-fuelled power stations
- Seawater desalination/reverse osmosis
- Process engineering
- Water treatment
- Water supply systems

Fluids handled

- Abrasive fluids
- Faecal-free waste water
- Aggressive fluids
- Inorganic fluids
- Brackish water
- Service water
- Solids-laden fluids
- River, lake and groundwater
- Fluids posing a health hazard
- Toxic fluids
- Highly aggressive fluids
- Condensate
- Corrosive fluids

- Valuable fluids
- Cooling water
- Fire-fighting water
- Solvents
- Seawater
- Fluids containing mineral oils
- Organic fluids
- Radioactive fluids
- Cleaning agents
- Grey water
- Brine
- Drinking water
- Wash water
- Other fluids on request.

Operating data

Operating properties

Characteristic	Value
Nominal pressure	PN16
Nominal size	DN 15-300
Permissible pressure	1-16 bar
Max. permissible temperature ¹⁾	-20 °C to +140 °C

Body materials

Overview of available materials

Material	Material number	Temperature limit
Nodular cast iron	JS1025	-20 °C to +140 °C

Design details

Design

- Soft-seated swing check valve in straight-way pattern
- Soft rubber encapsulated disc with slanted seat
- Internal hinge pin
- Marked to DIN/EN 19 (ISO 5209)
- The valves satisfy the safety requirements of Annex I of the European Pressure Equipment Directive 97/23/EC (PED) for fluids in Groups 1 and 2.
- The valves do not have a potential internal source of ignition and can be used in potentially explosive atmospheres, Group II, category 2 (zones 1+21) and category 3 (zones 2+22) to ATEX 94/9/EC.

Variants

- Body and cover lined with IIR (butyl); temperature limit: +120 °C
- Body and cover lined with NRH (hard rubber); temperature limit +100 °C

¹⁾ The temperatures indicated are for orientation only; they are not valid for all operating conditions.

- Body and cover coated with ECTFE (Halar); temperature limit +90 °C
- Body and cover coated with PA (Rilsan)²⁾; temperature limit +90 °C
- IIR-encapsulated disc; temperature limit +120 °C
- CSM-encapsulated disc; temperature limit +100 °C
- EPDM-encapsulated disc; temperature limit +140 °C
- NBR-encapsulated disc; temperature limit +90 °C
- Certification to customer specification

Product benefits

- Body geometry hydraulically optimised to provide low flow resistance coefficient
- The valve hydraulics without dead volume offers optimum conditions for high-purity fluids.
- Maintenance-free due to internal hinge pin
- Soft rubber encapsulated disc provides reliable shut-off

Related documents

- Operating manual 0570.821

On all enquiries/orders please specify

1. Type
2. Nominal pressure
3. Nominal size
4. Operating pressure
5. Differential pressure

6. Operating temperature
7. Fluid handled
8. Pipe connection
9. Variants
10. Number of type series booklet
11. Certificate

Flow characteristics

Flow coefficients

DN	RSK Kvs value [m³/h]	DN	RSKS Kvs value [m³/h]
25	16.0	25	16.0
40	40.0	40	-
50	63.0	50	63.0
65	-	65	97.0
80	160.0	80	160.0
100	230.0	100	230.0
125	391.0	125	391.0
150	532.0	150	532.0
200	-	200	1002.0
250	-	250	1384.0
300	-	300	2254.0

Pressure/temperature ratings

Permissible operating pressures in bar at a temperature of °C (to EN 1092-2/ EN 1092-1)

Nominal pressure	Material	-20	+100	+120	+140
16	JS1025	16	16	12	8

²⁾ In compliance with KTW recommendations for the use of elastomers in drinking water issued by the German Federal Office of Health .

Materials

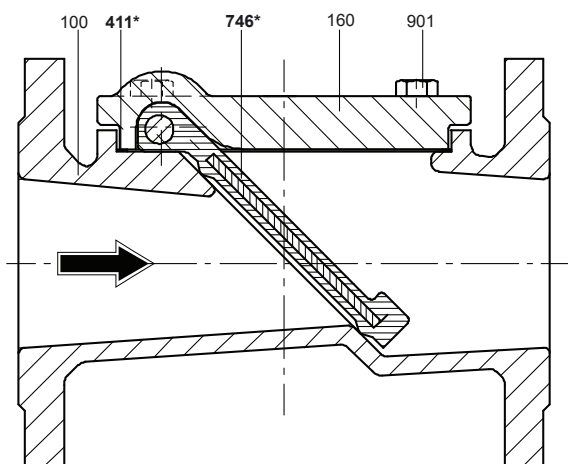

Horizontal installation position
Version with Rilsan or
Halar coating and without coating

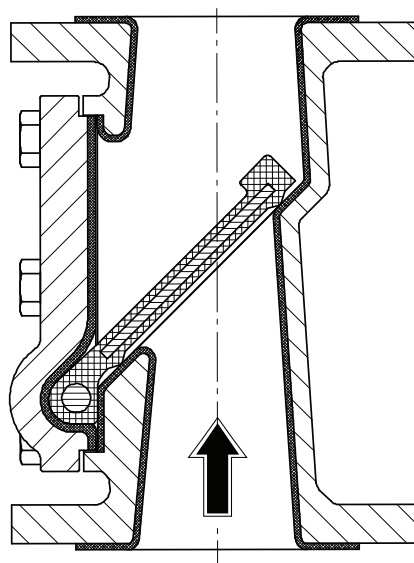

Vertical installation position³⁾
Version with NRH, IIR lining

Parts list

Part No.	Description	Material	Note
100	Body	JS1025/NRH	Standard
160	Cover	JS1025/NRH	Standard
411 ⁴⁾	Joint ring	EPDM	
746 ⁴⁾	Disc	St 52/IIR	Standard
901	Hexagon head bolt	A2-70	

³⁾ Vertical installation is only permitted if the fluid does not contain any solids.

⁴⁾ Recommended spare parts

Dimensions

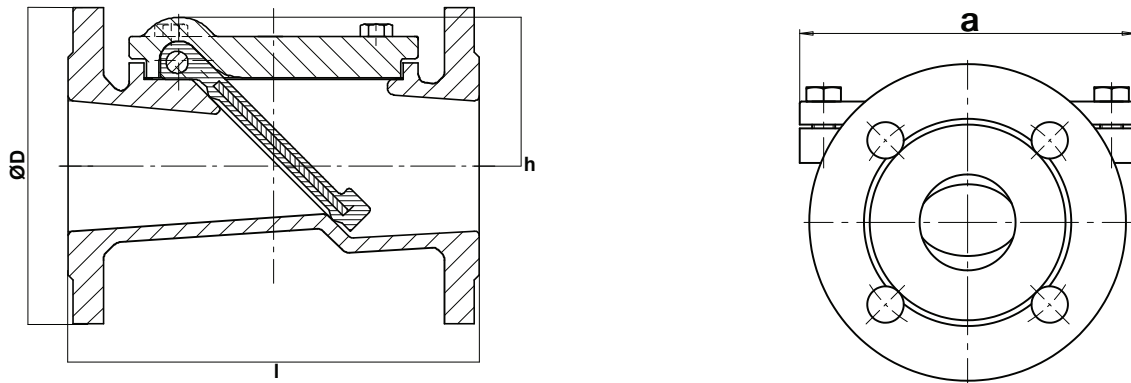

Dimensions in mm

DN	l		a		h	ØD	[kg]	
	RSK	RSKS	RSK	RSKS			RSK	RSKS
25	160	-	84	84	43	115	4	4
40	200	-	164	-	78	150	11	-
50	230	200	175	164	78	165	11	12
65	-	240	-	164	78	185	-	15
80	310	260	224	232	100	200	25	28
100	350	300	224	232	100	220	31	33
125	400	350	290	290	130	250	50	48
150	480	400	290	290	130	285	60	62
200	-	500	-	390	190	340	-	108
250	-	600	-	390	190	405	-	139
300	-	700	-	550	260	460	-	247

Mating dimensions - Standards

Face-to-face length of RSK:	EN 558-1 R1 (ISO 5752/1)
Face-to-face length of RSKS:	EN 558-1 R48
Flange connection:	DIN 2501 (ISO 2084/BS 4504)
Flange facing:	DIN EN 1092-2, type B

Vertical installation is only permitted if the fluid does not contain any solids.

If the valve is installed in vertical position, flow must be upwards.

The flow direction must correspond to the arrow indicated on the valve body.

Installation instructions

Swing check valves can be installed horizontally and vertically.



SISTO Armaturen S.A.
Zone Industrielle • L-6468 Echternach
Tel.: +352 325085-1 • Fax: +352 328956
E-Mail: sisto@ksb.com • www.sisto.lu

A KSB Company • 