

Globe Valve

BOA-Compact

PN 6/16
DN 15-200
Soft-seated
Flanged

Type Series Booklet



Legal information/Copyright

Type Series Booklet BOA-Compact

KSB Aktiengesellschaft Pegnitz

All rights reserved. Contents provided herein must neither be distributed, copied, reproduced, edited or processed for any other purpose, nor otherwise transmitted, published or made available to a third party without KSB's express written consent.

Subject to technical modification without prior notice.

© KSB Aktiengesellschaft Frankenthal 2011

Globe Valves

Soft-seated Globe Valves

BOA-Compact



Main applications

- Hot-water heating systems
- Air-conditioning systems
- Heat recovery systems

Fluids handled

- Water
- Water/glycol mixtures
- Not suitable for fluids containing mineral oils, steam or fluids liable to attack EPDM and cast iron.
- Other fluids on request.

Operating data

Operating properties

Characteristic	Value
Nominal pressure	PN 6/16
Nominal size	DN 15-200
Max. permissible pressure	16 bar
Max. permissible temperature	120 °C

Design details

Design

- Straight-way globe valve with slanted seat
- Slanted seat design
- Short face-to-face length to DIN EN 558/14
- Single-piece pressure-retaining body
- Non-rising handwheel

- Flanges to DIN EN 1092-2 Type 21
- Position indicator outside the insulating material
- Locking device, travel stop, position indicator, throttling plug and insulating cap with anti-condensation feature as standard
- Suitable for full insulation in acc. with German energy-saving regulations
- Non-rotating stem with protected, external thread
- Maintenance-free stem seal with EPDM profile ring
- Compact throttling plug with EPDM coating as soft main and back seat
- Exterior coating: blue RAL 5002
- The valves satisfy the safety requirements of Annex I of the European Pressure Equipment Directive 97/23/EC (PED) for fluids in Group 2.
- Type-tested to the specifications of Germanischer Lloyd

Variants

- Lead-sealable cap (prevents unauthorised actuation) as assembly set
- Electric actuators

Body materials

Overview of available materials

Material	Material number	Temperature limit
EN-GJL-250	JL 1040	up to 120 °C

Product benefits

- Zero leakage and zero maintenance for life due to lubricated-for-life EPDM profile ring and single-piece body.
- Minimal pressure drop due to hydraulically favourable flow passage.
- One model for shut-off and throttling: fully EPDM-coated throttling plug with linear characteristic.
- Easy insulation thanks to simple body design and anti-condensation feature (insulating cap).
- Fully equipped at no extra price: internal travel stop, position indicator and locking device included.
- Cost-effective transport and handling due to short face-to-face length and low weight.

Related documents

- For hydraulic balancing we recommend our BOA-Control IMS control valve with integrated sensor for flow rate and temperature measurement, and our BOATRONIC M measuring computer.
- For water supply systems and cooling circuits as well as drinking water applications we recommend our maintenance-free BOA-Compact EKB globe valves.
- For fluids containing mineral oils, temperatures exceeding 120 °C and low-pressure steam systems we recommend our maintenance-free BOA-H globe valves.
- The valves are also available as automated variants with electric actuators (continuous-action 24 V AC, 230 V AC) and 3-point (Open/Stop/Closed) actuators (24 V AC, 230 V AC) as BOA-CVE globe valves.

Other applicable documentation

Document	Reference No.
Valve characteristics	7112.4
Operating manual	0570.8

Document	Reference No.
Installation instructions "Accessories set for capped valves"	0570.811
BOA-Compact EKB type series booklet	7112.11
BOA-Control IMS type series booklet	7128.1
BOA-CVE globe valves type series booklet	7520.1
BOA-H type series booklet	7150.1

On all enquiries/orders please specify

- Type
- Nominal pressure
- Nominal size
- Variants
- Number of type series booklet

Pressure/temperature ratings

Test and operating pressures

Nominal pressure	Nominal size	Body pressure test	Seat tightness test	Permissible operating pressures ¹⁾
		with water		
		P10, P11 ²⁾	P12 ³⁾	-10 to +120 °C
PN	DN	[bar]	[bar]	[bar]
6	15-200	9	6,6	6
16	15-200	24	17,6	16

¹⁾ Static load

²⁾ DIN EN 12266-1 (P10, P11)

³⁾ Test procedure to DIN EN 12266-1 (P12, leakage rate A)

Materials

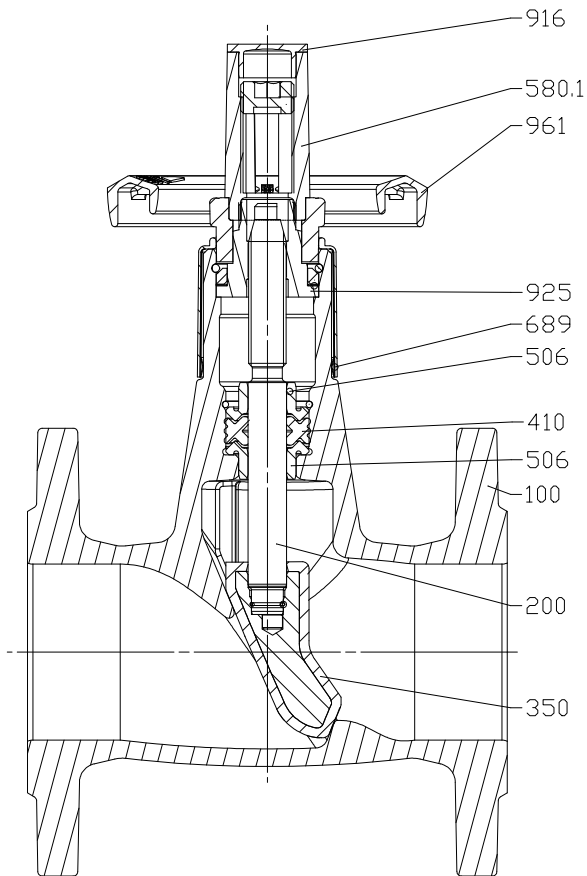

DN 15-150

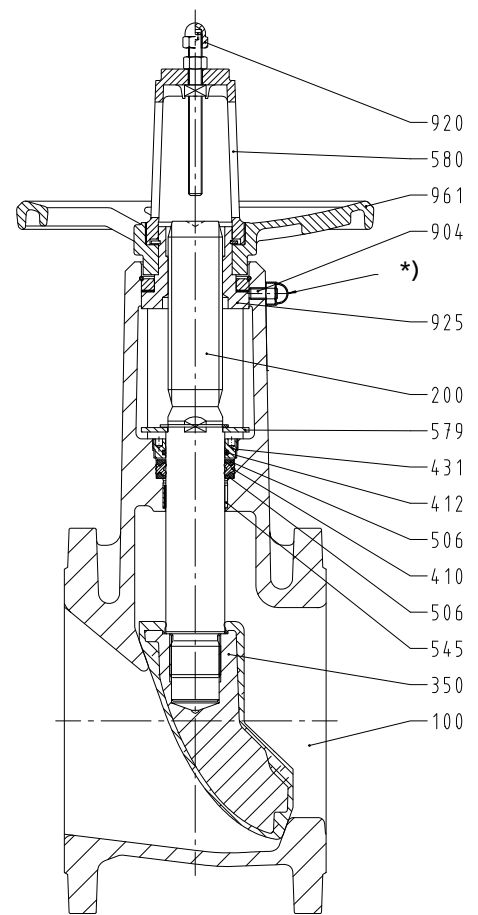

DN 200

Overview of available materials

Part No.	Description	Material	Note
100	Body	EN-GJL-250 (JL1040)	
200	Stem	Stainless steel, min. 13 % chrome (Cr)	
350	Valve disc	Grey cast iron/EPDM	
410	Profile joint	Elastomer EPDM	
506	Retaining ring	Plastic	DN 20-150
		Galvanised steel	DN 200
580.1	Cap	Plastic, glass-fibre reinforced, impact-resistant	
689	Insulating cap	Plastic	
903	Travel stop	Galvanised steel	
904	Locking device	Galvanised steel	
916	Plug	Plastic	
925	Stem nut	Galvanised steel	
961	Handwheel	Aluminium, die-cast	
		Plastic, glass-fibre reinforced, impact-resistant	DN 15-25
		Grey cast iron (JL1030)	DN 200

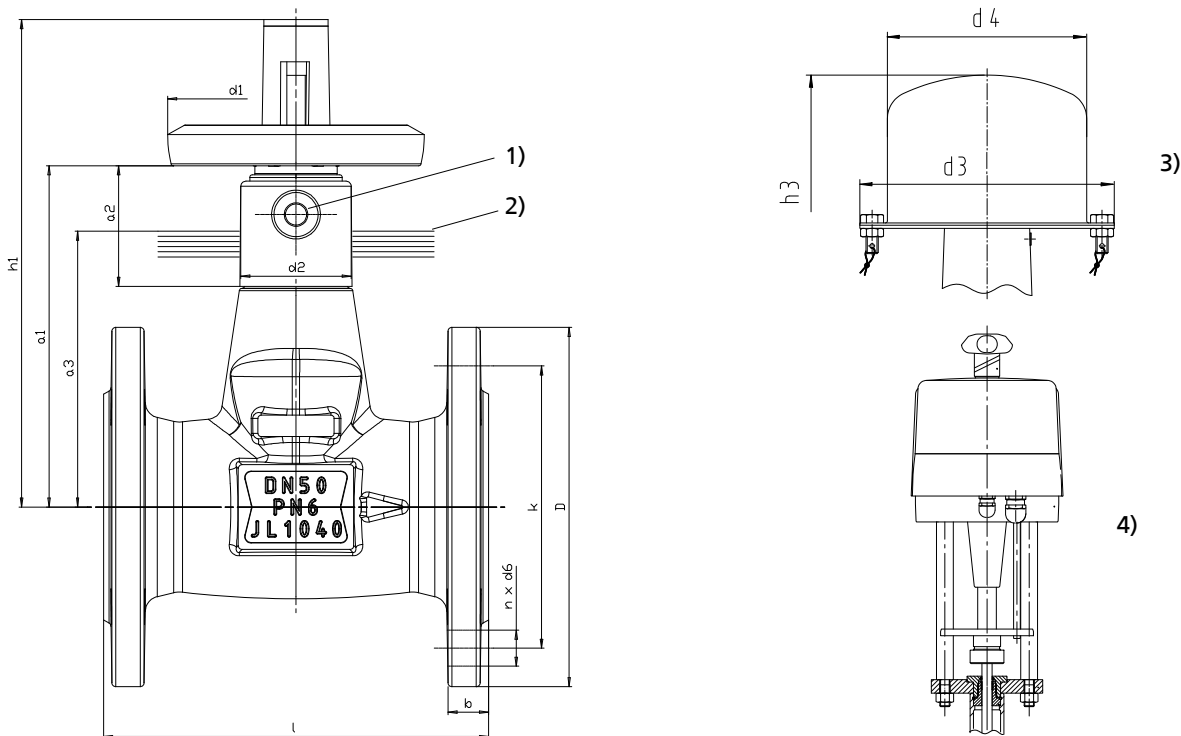
Dimensions

1)	Locking device	2)	Insulating boundary in acc. with German energy-saving regulations
3)	Lead-sealable cap (prevents unauthorised actuation) as assembly set	4)	With electric actuator (BOA-CVE globe valves)

Dimensions in mm

PN	DN	l	h_1	d_1	d_2	a_1	a_2	a_3	Flange					[kg]	Capped valve		
									D	b	k	n	d_6		d_3	d_4	h_3
6	15	115	156	80	35	105	46	50	80	12	55	4	11	1,7	166	130	195
	20	120	156	80	35	105	46	55	90	14	65	4	11	2,1	166	130	195
	25	125	156	80	35	105	46	65	100	14	75	4	11	2,3	166	130	195
	32	130	179	100	35	122	46	75	120	16	90	4	14	3,8	166	130	210
	40	140	179	100	35	122	46	85	130	16	100	4	14	4,3	166	130	210
	50	150	189	100	43	131	46	95	140	16	110	4	14	4,9	166	130	220
	65	170	252	125	47	174	66	112,5	160	16	130	4	14	7,7	166	130	260
	80	180	252	160	52	185	76	135	190	18	150	4	19	10,9	210	170	310
	100	190	298	160	63	215	73	155	210	18	170	4	19	14,7	210	170	350
	125	200	373	200	85	270	115	170	240	20	200	8	19	21,0	270	220	435
150	210	386	250	85	282	113	182,5	265	20	225	8	19	26,5	390	340	460	
200	230	693	315	136	434	174	220	340	30	280	8	19	71,0	390	340	600	
16	15	115	156	80	35	105	46	57,5	95	14	65	4	14	2,3	166	130	195
	20	120	156	80	35	105	46	62,5	105	16	75	4	14	2,7	166	130	195
	25	125	156	80	35	105	46	72,5	115	14	85	4	14	3,0	166	130	195
	32	130	179	100	35	122	46	85	140	18	100	4	19	4,8	166	130	210
	40	140	179	100	35	122	46	95	150	18	110	4	19	5,5	166	130	210
	50	150	189	100	43	131	46	107,5	165	20	125	4	19	6,9	166	130	220
	65	170	252	125	47	174	66	125	185	20	145	4	19	10,0	166	130	260
	80	180	252	160	52	185	76	140	200	22	160	8	19	12,5	210	170	310
100	190	298	160	63	215	73	160	220	24	180	8	19	17,1	210	170	350	

PN									Flange					[kg]	Capped valve		
	DN	l	h ₁	d ₁	d ₂	a ₁	a ₂	a ₃	D	b	k	n	d ₆		d ₃	d ₄	h ₃
	125	200	373	200	85	270	115	175	250	26	210	8	19	26,5	270	220	435
	150	210	386	250	85	282	113	192,5	285	26	240	8	23	31,0	390	340	460
	200	230	693	315	136	434	174	220	340	30	295	12	23	71,0	390	340	600

Mating dimensions - Standards

Face-to-face lengths: DIN EN 558 FTF-14, ISO 5752/14
 Flanges: DIN EN 1092-2, flange type 21
 Raised face: DIN EN 1092-2, type B

Installation instructions

Flow through the shut-off globe valves should be in the direction of the embossed arrow on the valve body. An alternating direction of flow is permissible, however.

 EN 1515-4 "Selection of bolting for equipment subject to the Pressure Equipment Directive 97/23/EC" and any plant regulations governing the application in question must be observed when selecting connecting elements between the valve flange and the pipe flange.

Chemical resistance chart

The information provided in this chemical resistance chart is based on experience, the Dechema lists as well as manufacturer information. Corrosion resistance is largely dependent on the operating conditions, temperatures and concentrations. Hydroabrasive wear in fluids containing solids is not covered in this list. All information provided herein, therefore, only serves as an orientation. Warranty claims may not be asserted on the basis of this list!

Chemical resistance chart for water⁴⁾

Fluid handled	Max. content	Max. temp.	
Bathing water (fresh water)			○
Bathing water (seawater)			✘
Brackish water			✘
Service water			○
Chlorinated water	0,6 mg/kg		✓
Deionised water (demineralised water)			✘
Distilled water			✘
Heating water			✓
Condensate			○
Oil-free cooling water			○
Oil-containing cooling water			✘
Seawater			✘
Ozonised water	0,5 mg/kg		✓
Pure water			✓
Raw water			○
Waste water ⁵⁾			✓
Partly desalinated water			○
Thermal water			✘
Drinking water			✘
Fully desalinated water			✘

Chemical resistance chart for oils (aromatic content 5 mg/kg)

Fluid handled	Max. content	Max. temp.	
Vegetable oils			✘
Mineral oils			✘
Synthetic oils			✘
Petroleum			✘
Oil-water emulsion			✘
Kerosene			✘

Chemical resistance chart for refrigerants

Fluid handled	Max. content	Max. temp.	
Ammonium hydroxide	25 %	25 °C	✓
Glycol (ethylene glycol)			✓
Water-glycol mixture	50 %	90 °C	✓
Inorganic cooling brine, pH 7,5 inhibited			✓

Chemical resistance chart for cleaning agents

Fluid handled	Max. content	Max. temp.	
Lye for bottle rinsers (e.g. P3)			✓
Lye for metal cleaning			✘

Chemical resistance chart for other fluids

Fluid handled	Max. content	Max. temp.	
Landfill gas			○
Oil-containing compressed air			✘
Aqueous glycerine			○
Carbon dioxide (gas)			✓
Carbon dioxide (aqueous solution)			✘
Oxygen O ₂			✘

Key to the symbols

Symbol	Description
✓	The fluid handled normally does not attack the materials. Valve can be used if ⁴⁾ and ⁵⁾ are observed.
✘	The fluid handled is aggressive to the materials. Valve cannot be used.
○	The material or valve can only be used under certain operating conditions. Please enquire accordingly stating the operating conditions such as concentration, temperature, pH value and composition of the fluid handled.

⁴⁾ General criteria for water to be handled by valves made of non-alloyed materials: pH value 6,5 - 12; chlorides (Cl-) < 150 mg/kg; chlorine (Cl) < 0,6 mg/kg. Other factors to be considered: hardness, carbon dioxide content (CO₂), oxygen (O₂) and dissolved substances. Contact KSB if limits are exceeded!
⁵⁾ Without larger solids or stringy material



KSB Aktiengesellschaft

Johann-Klein-Straße 9 • 67227 Frankenthal (Germany)

Tel. +49 6233 86-0 • Fax +49 6233 86-3476

E-Mail: valves@ksb.com • www.ksb.com