

**Standardised water pump
with canned motor**

Automation products available:

- PumpExpert
- Hyamaster
- hyatronic

Fields of Application

For handling aggressive, inflammable, toxic, volatile or valuable liquids in the chemical and petrochemical industries as well as in environmental and industrial engineering.

Etaseco is also suitable for applications requiring low noise emissions, particularly smooth running or long service intervals (operating reliability).

Design

Etaseco

Horizontal/vertical, sealless volute casing pump in back pull-out design, with fully enclosed canned motor, fitted with a radial impeller, single-stage, single-entry.

The connection dimensions of the pump casing comply with EN 733.

Etaseco-I

Inline pump in back pull-out design, with fully enclosed canned motor, fitted with a radial impeller, single-stage, single-entry.

Drive

Three-phase, asynchronous canned motor, enclosure IP 55, without explosionproof status. Thermal motor protection by means of PTC thermistors. The motor design is in accordance with IEC 60 034 (DIN VDE 0530).

Designation

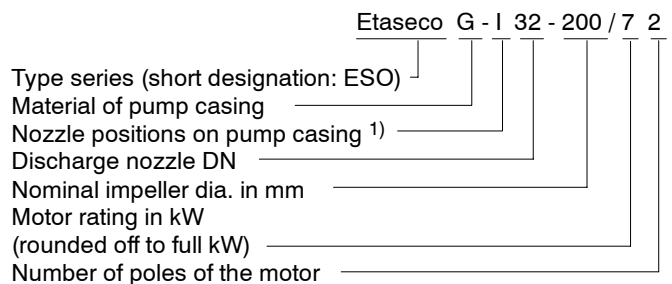

1) without letter: 90° (axial suction nozzle, radial discharge nozzle)
- I: 180° (suction and discharge nozzle in opposite position)

Operating Data

Capacities	Q up to 250 m ³ /h
Heads	H up to 100 m
Motor ratings	P ₂ from 1,4 to 18 kW
Product temperature	t - 40 to 140 °C
p ₂	up to 16 bar ²⁾

2) The sum of inlet pressure and head at zero flow point must not exceed the value indicated.

Certification

Certified quality management ISO 9001.

Selection Chart

Etaseco G, S

n = 2900 1/min

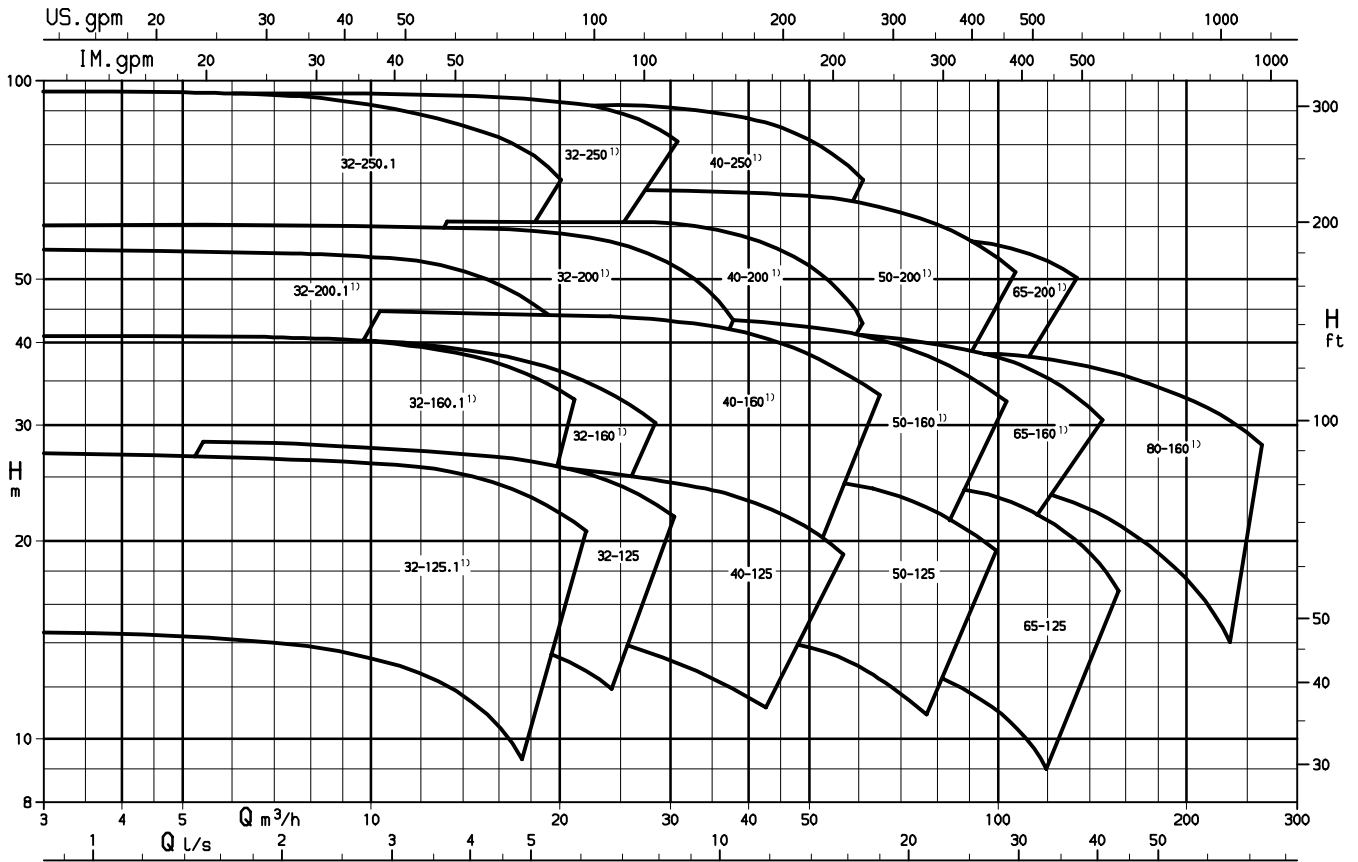

1) Etaseco also available in nodular cast iron

Etaseco G-I

n = 2900 1/min

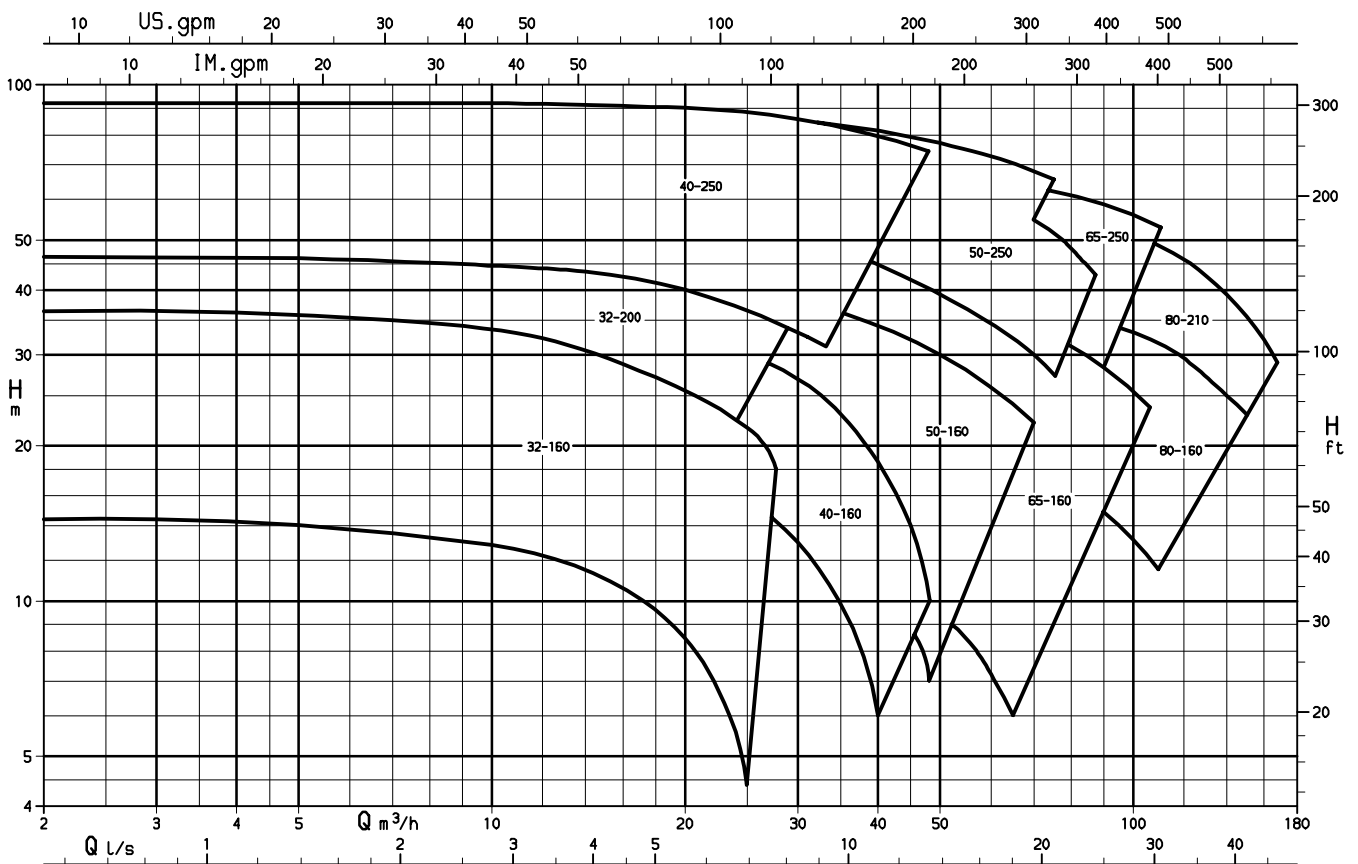

Etaseco S-I

n = 2900 1/min

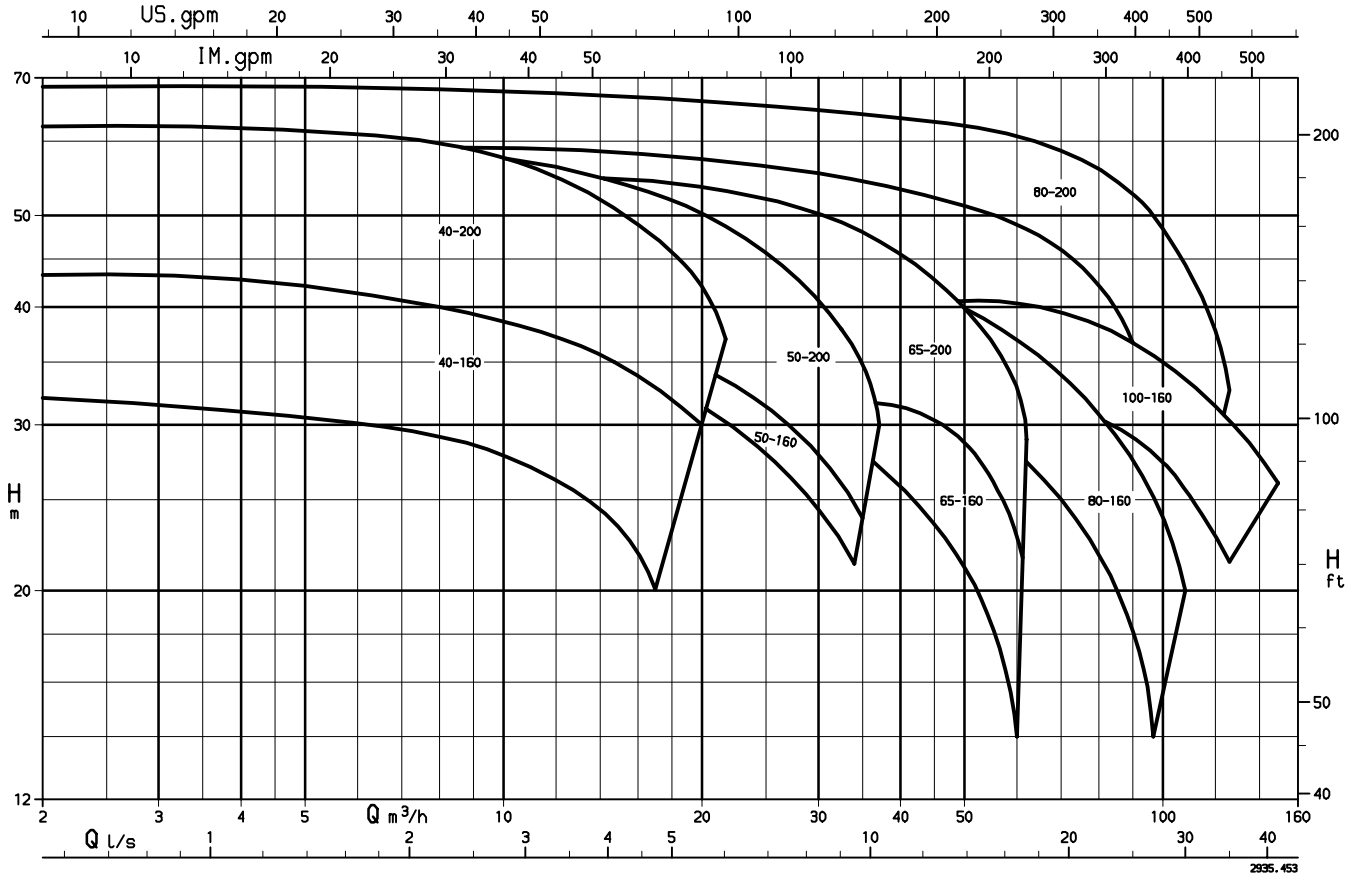
Pump/Motor Modular System

Code	Size																							
	32-125.1	32-160.1	32-200.1	32-250.1	32-125	32-160	32-200	32-250	40-125	40-160	40-200	40-250	50-125	50-160	50-200	50-250	65-125	65-160	65-200	65-250	80-160	80-200	80-210	100-160
12	0,1	0,1	-	-	0	0,1,2	-	-	0	0,1,2,3	-	-	0	0,1,2,3	-	-	0	2,3	-	-	3	-	-	-
22	0,1	0,1	-	-	0	0,1,2	-	-	0	0,1,2,3	-	-	0	0,1,2,3	-	-	0	2,3	-	-	3	-	-	-
42	0,1	0,1	0,1	0	0	0,1,2	0,1,2	0,1	0	0,1,2,3	0,1,3	0,1,2	0	0,1,2,3	0,1,3	2	0	0,1,2,3	0,1,3	2	0,1,2,3	3	2	2,3
52	0,1	0,1	0,1	0	0	0,1,2	0,1,2	0,1	0	0,1,2,3	0,1,3	0,1,2	0	0,1,2,3	0,1,3	2	0	0,1,2,3	0,1,3	2	0,1,2,3	3	2	2,3
72	-	0,1	0,1	0	-	0,1,2	0,1,2	0,1	-	0,1,2,3	0,1,3	0,1,2	0	0,1,2,3	0,1,3	2	0	0,1,2,3	0,1,3	2	0,1,2,3	3	2	2,3
112	-	0,1	0,1	0	-	0,1,2	0,1,2	0,1	-	0,1,2,3	0,1,3	0,1,2	0	0,1,2,3	0,1,3	2	0	0,1,2,3	0,1,3	2	0,1,2,3	3	2	2,3
152	-	0,1	0,1	0	-	0,1,2	0,1,2	0,1	-	0,1,2,3	0,1,3	0,1,2	0	0,1,2,3	0,1,3	2	0	0,1,2,3	0,1,3	2	0,1,2,3	3	2	2,3

0 = Etaseco G 1 = Etaseco S 2 = Etaseco G-I 3 = Etaseco S-I - = combination not possible

Material

Part No.	Description	Material G	Material S
102	Volute casing	JL 1040 ⁵⁾	JS 1025 ⁶⁾
161	Casing cover	JS 1025 ¹⁾⁶⁾	JS 1025 ⁶⁾
230	Impeller	JL 1040 ⁵⁾	JL 1040 ⁵⁾
344 ²⁾	Bearing bracket lantern	JS 1025 ⁶⁾	JS 1025 ⁶⁾
412.21/.22	O-ring	FPM	FPM
412.02/.11/.41/.71	O-ring (set)	EPDM ³⁾	EPDM ³⁾
529.06/.21	bearing sleeve	Sicadur ^{® 8)}	Sicadur ^{® 8)}
545.06/.21	bearing bush	Sicadur ^{® 8)}	Sicadur ^{® 8)}
811	casing	St 35.8 ⁷⁾	St 35.8 ⁷⁾
817.01	can	2.4610	2.4610
818	shaft	1.4021	1.4021

- 1) for motors 12 and 22: JL 1040
- 2) omitted for motors 12 and 22
- 3) also available in FPM
- 4) Pairing of bearing: 1.4462/carbon upon request
- 5) to EN 1561 = GJL-250
- 6) to EN 1563 = GJS-400-18-LT
- 7) for motors 12 and 22 also available in JS1025
- 8) Sicadur [®] = SiC ⁴⁾



Advantages at a Glance

Reliable due to well-proven hydraulic elements of the ETA pump range with excellent efficiencies and NPSH values. Connecting dimensions to EN 733.

High operating reliability due to hydraulic separator: minimised solids content in the cooling flow. Additional connection for filtered product or external cooling liquid possible.

High functional reliability due to self-venting feature of the pump unit via the hollow shaft and radial bores.

Safe due to thermal motor protection and corrosion-resistant materials for can and rotor cladding.

Simple electrical installation Terminal box as on standardised IEC motors

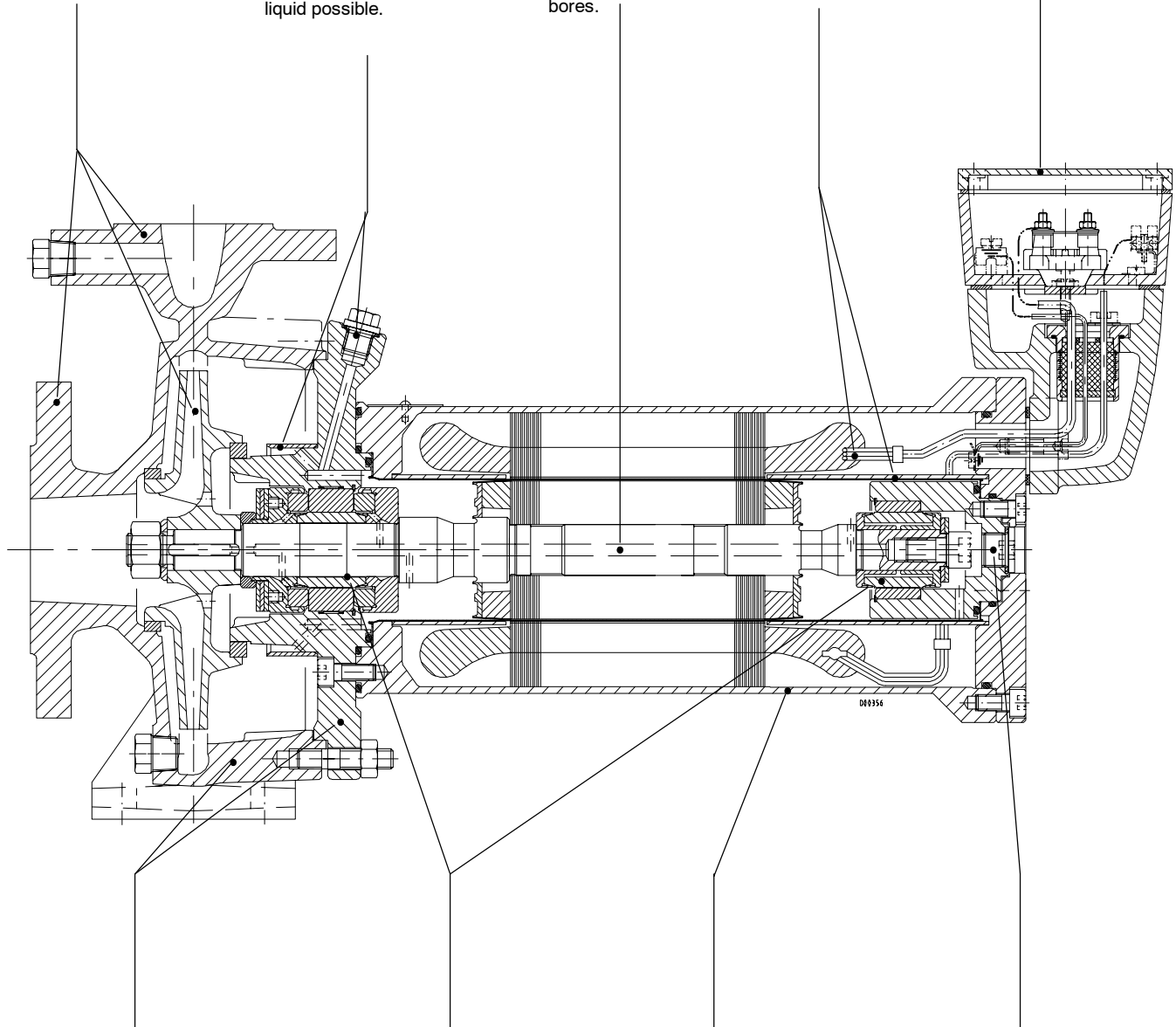

Space-saving and easy to install due to close-coupled design

Long service life due to high-quality plain bearings with long inspection intervals.

Leakage-free, maintenance-free and low-noise, due to canned motor technology

Easy drainage and cleaning, due to flushing connection

Drive

Fully enclosed three-phase, asynchronous canned motor, enclosure IP 55. Thermal motor protection by means of PTC thermistors. The motor design is in accordance with IEC 60 034 (DIN VDE 0530)

Acceptance Tests / Guarantees

- **Materials Tests:**
Test report 2.2 on request
- **Product test**
Inspection certificate 3.1, on request, for:
pressure test of complete pump as per EN 10 204
- **Hydraulic tests:**

The following acceptance tests may be performed and certified at extra charge:

Performance test ISO 9906

NPSH test

Warranties are given within the scope of the valid delivery conditions.

Recommended Stock of Spare Parts for 2 Years' Operation

With a view to the special design of the pump sets, the manufacturer has developed a special concept for spare parts and after-sales services.

Consequently, the manufacturer will always have replacement drives on stock in order to restore the pump set's availability in

Coating and Preservation

(to works standard AN 1865)

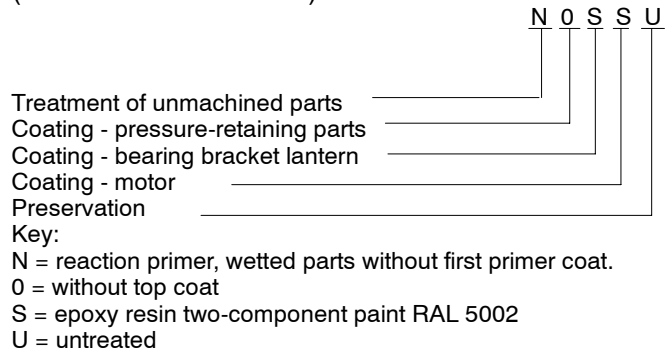

Key:

N = reaction primer, wetted parts without first primer coat.

O = without top coat

S = epoxy resin two-component paint RAL 5002

U = untreated

the plant as quickly as possible. Repairs of the drive at the site are not provided for, except for replacing spare parts.

Depending on the number of pump sets installed, the operator should keep the following spare parts on stock:

Part No.	Part description	Number of pumps (incl. standby pumps)						
		2	3	4	5	6	8	10 and more
		Quantity of spare parts						
161	Casing cover	-	-	-	1	1	1	10%
230	Impeller	1	1	2	2	2	3	30%
314.01/.02	Thrust bearing	-	-	-	1	1	1	10%
344	Bearing bracket lantern 1)2)	-	-	-	1	1	1	10%
382	Bearing carrier	-	-	-	1	1	1	10%
515.23/.24	Taper lock ring	-	-	-	1	1	1	10%
529.06/.21	Bearing sleeve	-	-	-	1	1	1	10%
	Motor unit 1)	-	-	-	1	1	1	10%
818	Rotor 1)	-	-	-	1	1	1	10%
	Set of sealing elements	2	2	4	4	6	8	100%
	Motor	-	-	-	1	1	1	10%

1) If more than 5 identical motors are in operation, we recommend to keep a complete motor on stock instead of the parts indexed 1).

2) not fitted on motor sizes 12 and 22

Technical data

		Pump sizes																									
		Unit	32-125.1	32-160.1	32-200.1	32-250.1	32-125	32-160	32-200	32-250	40-125	40-160	40-200	40-250	50-125	50-160	50-200	50-250	65-125	65-160	65-200	65-250	80-160	80-200	80-210	100-160	
General	impeller outlet width	mm	5	5.6	6	8	9.6	5.6	6	8	14	12	9	8	20	16	11.5	12	25.6	21	17	14	31.5	23.5	17	36	
	impeller inlet Ø	mm	50	56	56	58	56	56	56	58	70	70	68	70	76.5	75.5	75.5	80	96	92	93	97	124	115	93	142	
	max. impeller Ø	mm	see individual curve																								
	min. impeller Ø	mm	see individual curve																								
Pressure limit	max. operating pressure	bar	16 bar																								
	max. test pressure	bar	1.5 x max. permissible pump discharge pressure																								
Temp. limit	max. product temp.	°C	140 °C																								

Motor Data

General:

Three-phase asynchronous motor

Operating mode to DIN VDE 0530: S1

Starting method:

all motors d.o.l.: for 400 V Y/Δ starting is possible for motors 42 to 152

Voltages:

50 Hz: 400 V, 500 V; from motor 42 upwards, 690 V is also possible

60 Hz: 480 V, 600 V

Admissible voltage tolerance:

± 10%

Enclosure to DIN VDE 0530:

IP 55

Thermal class:

H

Monitoring:

PTC thermistors in standard pump design; thermal motor protection possible; (temperature in the rotor chamber can be monitored by means of PT 100 on the support sleeve)

Motor Data for 2-pole Motors

Motor code	Motor size DS	Product temp. °C	Operating data at rated power								Start- ing current for d.o.l. starting a multiple of J _N	Start- ing torque M _N	Pull- out torque M _N	Mo- ment of inertia J kgm ²	Weight (compl. drive) kg
			Rated current J _N (A) at			Speed n _N 1/min	Rated power P ₂ kW	Effi- ciency 1) %	Service factor cos φ	Torque M _N Nm					
			400 V	500 V	690 V										
12	90.2-1.1	40	3.7	3.0	-	2790	1.7	76.0	0.88	5.8	4.2	1.9	2)	0.003	35
		70	3.7	3.0	-	2790	1.7	76.0	0.88		4.2				
		100	3.3	2.7	-	2820	1.5	76.5	0.86		4.7				
		140	2.6	2.1	-	2880	1.1	76.5	0.80		6.0				
22	90.2-2.2	40	7.2	5.8	-	2785	3.2	75.1	0.86	11.0	4.3	2.0	2)	0.003	35
		70	6.7	5.4	-	2810	2.9	75.6	0.84		4.7				
		100	5.8	4.7	-	2845	2.4	75.8	0.80		5.4				
		140	4.1	3.3	-	2930	1.1	68.2	0.58		7.6				
42	112.2-4	40	12.3	9.8	7.1	2840	5.5	79.3	0.82	18.5	4.3	1.7	2)	0.006	57
		70	10.8	8.6	6.3	2860	4.8	79.6	0.81		4.8				
		100	9.5	7.6	5.5	2885	4.1	79.5	0.79		5.5				
		140	6.6	5.3	3.8	2940	2.3	75.1	0.68		7.9				
52	112.2-5.5	40	17.1	13.7	9.9	2860	8.1	81.6	0.84	27.1	5.0	2.0	2)	0.008	62
		70	15.6	12.5	9.1	2880	7.3	81.7	0.83		5.5				
		100	13.3	10.7	7.7	2900	6.0	81.2	0.81		6.4				
		140	9.1	7.3	5.3	2945	3.3	76.2	0.69		9.5				
72	132.2-7.5	40	22.9	18.3	13.3	2865	11.4	82.4	0.87	38.1	4.4	1.7	2)	0.021	72
		70	20.4	16.3	11.8	2880	10.2	82.9	0.87		4.9				
		100	17.7	14.2	10.3	2900	8.8	83.0	0.87		5.6				
		140	12.5	10.0	7.2	2940	5.9	81.3	0.84		8.0				
112	132.2-11	40	30.3	24.2	17.6	2905	15.0	83.1	0.86	49.4	5.6	2.4	2)	0.026	72
		70	27.4	21.9	15.9	2915	13.4	82.9	0.85		6.2				
		100	23.4	18.7	13.6	2930	11.1	82.1	0.83		7.3				
		140	15.7	12.6	9.1	2960	6.0	76.1	0.73		10.9				
152	132.2-15	40	35.9	28.7	20.8	2900	18.5	83.7	0.89	60.9	5.6	2.2	2)	0.030	85
		70	32.1	25.7	18.6	2910	16.4	83.6	0.88		6.2				
		100	28.0	22.4	16.3	2920	14.0	83.1	0.87		7.1				
		140	18.9	15.1	11.0	2950	8.3	78.9	0.81		10.6				

1) without liquid fill

2) Contact KSB.

Documentation

Printed documentation in compliance with CE requirements

- Product introduction
- Sectional drawing with list of components
- Dimensions table
- Installation plan
- Performance curves 50 Hz / 60 Hz
- Operating instructions
- Certificate of conformity

Noise Characteristics

Motor code	Motor size DS	Surface sound pressure level L pA (dB) ¹⁾
12	90.2-1.1	48.5
22	90.2-2.2	48.5
42	112.2-4	52
52	112.2-5.5	53
72	132.2-7.5	55
112	132.2-11	58
152	132.2-15	60

1) Measured at a distance of 1 m from the pump outline (to DIN 45635, Parts 1 and 24)

Accessories available

- **PTC tripping unit** (connection see fig. 1)
The PTC tripping unit (0A1) protects and monitors motors equipped with thermistors (PTCs). The standard Etaseco pump is equipped with thermistors. The temperature sensors are fitted into the stator windings of the motor where they directly measure the temperature rise in the motor. The following operating conditions can be monitored directly:
 - sluggish starting
 - high switching frequency
 - single-phase operation
 - high ambient temperature
 - insufficient cooling
 The tripping unit works independently of the rated motor current, insulation class and starting method.
- **Pump performance control unit (motor load control unit)** monitors the effective power consumption of the motor. Two potentiometers can be set to the maximum and/or minimum power consumption. If the motor power consumption falls short of, or exceeds, the set limit values, 2 LEDs will signal underload, or overload, respectively. Following an adjustable trip delay of 1 ... 10 s, the corresponding output relay is activated. The control unit also features an adjustable start-up delay of 1 ... 30 s, as well as an LED for signaling that the unit is operational.
 - monitoring maximum power limits the max. flow rate with a view to cavitation-free pump operation and motor overloading.
 - monitoring minimum power protects the pump from dry-running if medium is not available (no-load power)

N.B.: For rated motor currents above 5 A, a current transformer is required for the motor load control unit.

- **Motor standstill heater**
By the motor standstill heater a lowered heating voltage is applied to the motor as compared to the mains voltage. The current flowing at this voltage heats up the motor winding, thus also heating up the liquid in the rotor chamber. The liquid temperature in the rotor chamber can be set to a limit value via a temperature sensor (PT 100) mounted at the rotor chamber. Due to the functioning of the standstill heater a rotation of the motor shaft is not possible.
- **Main flow filter** (see fig. 2)
A main flow filter can be installed between the pump discharge nozzle and the plant pipeline. While the pumped product flows in axial direction, a partial flow is tapped in radial direction and used for motor cooling and bearing lubrication. After the partial flow has been routed through a strainer (0.08 x 2 mm longitudinal slots), hardly any solids can enter the rotor chamber. The main flow filter is selfcleaning, as the main flow passes parallel to the strainer surface and carries away the solids.

Sealing liquid connection 10 E

For solids-laden products, connection 10 E can be fed with pumped product passed through a self-cleaning main flow filter (fig. 2) or with an external sealing liquid (fig. 3), thus preventing contaminations from entering the rotor chamber. If a KSB filter is used, pump dimension h2 will increase by 60 mm. Any external sealing liquid used must be compatible with the pumped product. **It is advisable to use PTC thermistors i.e. monitoring the temperature in the stator windings, in both cases, in order to prevent motor failures caused by insufficient cooling flow.**

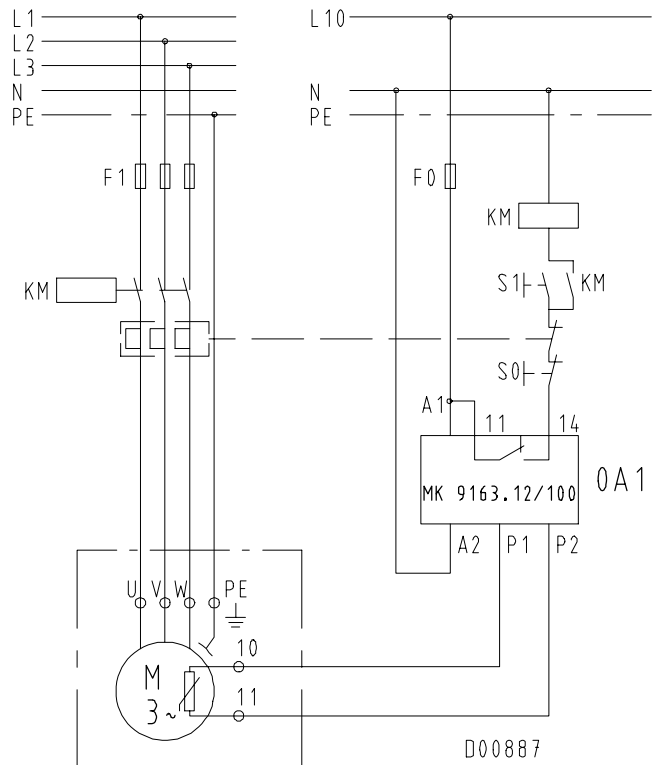

Fig. 1 Standard wiring diagram

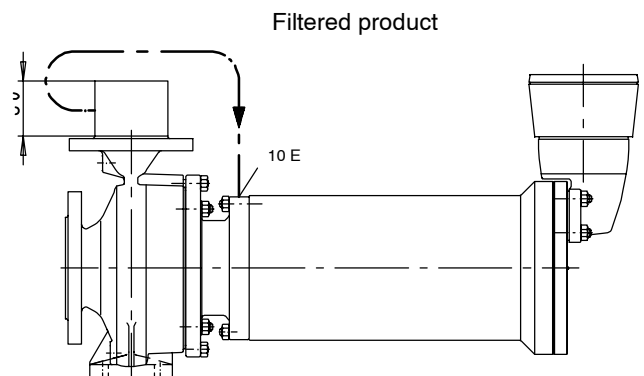

Fig. 2 Sealing with filtered product

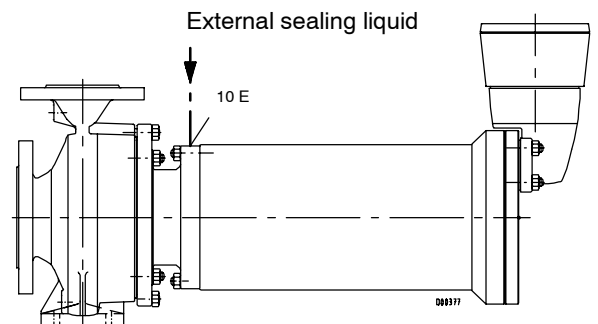
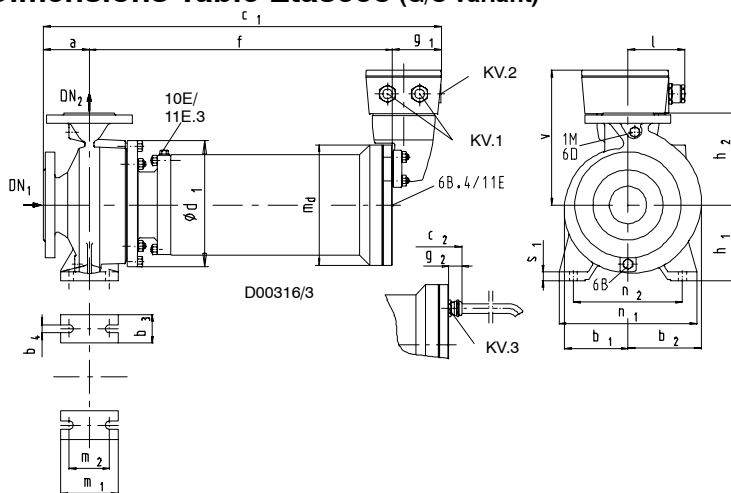

Fig. 3 Sealing with external liquid

Pumped product ^{4) 5)}	Application limits	
	Content max. %	Temp. max. °C
Alkaline cleaning agents		30
Ammonia water	25	30
Bottle rinsing lyes		50
Castor oil ¹⁾		
Caustic soda ⇒ Sodium hydroxide	29	30
Cider		
Corn oil ¹⁾		
Cutting oil		
Edible oil ¹⁾		
Glycol-water mixture		
Hydraulic oil		
Linseed oil		
Lubricating oil		
Metal cleaning lyes, pH ≤ 12		50
Mineral oil		
Oil-water emulsion		
Peanut oil ¹⁾		
Potassium bicarbonate	10	20
Potassium carbonate	50	30
Potassium hydroxide	29	30
Rape oil ¹⁾		
Safety refrigerants, water-free (e.g. Frigen, Freons)		
Silicone oil		
Sodium bicarbonate	10	20
Sodium carbonate	10	30
Sodium hydroxide ⇒ caustic soda	29	30
Sodium nitrate	40	30
Soybean oil ¹⁾		
Turbine oil (not SFD oils, not combustible)		
Vaseline		
Vegetable oils, pure ¹⁾		
Water ²⁾		
Bath water		40
Boiler water		
Cooling water		40
Dam water		25
Drinking water		40
Fire-fighting water		25
Heating water ³⁾		
Partly desalinated water		40
Pure water		40
Pure water with 10 % soda		30
Raw water		40
Rinsing water		40
Slightly contaminated water		25

- 1) not food-approved
- 2) General criteria for results of water analysis: pH value ≥ 6.5; chloride (Cl) content ≤ 150 mg/kg. Chlorine (Cl₂) ≤ 0.6 mg/kg. Please contact KSB if limits are exceeded.
- 3) conductivity at 25 °C: < 250 μS/cm. SiO₂ (silicate) content ≤ 10 mg/l.
- 4) O-ring material FPM: admissible upto -30 °C only
EPDM: admissible upto -40 °C
- 5) Carbon bearings can only be used for products with a low solids content (< 20 ppm) and low particle hardness (Mohs' hardness ≤ |4|)

Dimensions Table Etaseco (G/S variant)



Pump dimensions

Dimensions in mm

Pump size	Pump dimensions														Total weight (approx., kg)					
	DN ₁	DN ₂	a	b ₁	b ₂	b ₃	b ₄	h ₁	h ₂	m ₁	m ₂	n ₁	n ₂	s ₁	12/22	42	52	72/112	152	Ød ₁ + ³
32-125.1/...	50	32	80	113	113	50	14	112	140	100	70	190	140	15	52	74	81	-	-	225
32-160.1/...	50	32	80	116	125	50	14	132	160	100	70	240	190	15	53	76	83	107	119	225
32-200.1/...	50	32	80	128 ²⁾	137 ²⁾	50	14	160	180	100	70	240	190	18	-	82	89	113	125	275
32-250.1/...	50	32	100	164	171	65	14	180	225	125	95	320	250	18	-	89	96	120	132	320
32-125/...	50	32	80	113	113	50	14	112	140	100	70	190	140	15	53	75	82	-	-	225
32-160/...	50	32	80	113	125	50	14	132	160	100	70	240	190	15	54	76	83	107	119	225
32-200/...	50	32	80	132 ²⁾	141	50	14	160	180	100	70	240	190	18	-	82	89	113	125	275
32-250/...	50	32	100	170	176	65	14	180	225	125	95	320	250	18	-	90	97	121	133	320
40-125/...	65	40	80	113	113	50	14	112	140	100	70	210	160	15	54	76	83	-	-	225
40-160/...	65	40	80	115	131	50	14	132	160	100	70	240	190	15	56	78	85	109	121	225
40-200/...	65	40	100	115 ²⁾	131 ²⁾	50	14	160	180	100	70	265	212	18	-	83	90	114	126	275
40-250/...	65	40	100	165	178	65	14	180	225	125	95	320	250	18	-	91	98	122	134	320
50-125/...	65	50	100	113	128	50	14	132	160	100	70	240	190	18	57	79	86	110	122	225
50-160/...	65	50	100	126	147	50	14	160	180	100	70	265	212	18	59	81	88	112	124	225
50-200/...	65	50	100	145	165	50	14	160	200	100	70	265	212	18	-	85	92	116	128	275
65-125/...	80	65	100	120	148	65	14	160	180	125	95	280	212	18	62	84	91	115	127	225
65-160/...	80	65	100	130	158	65	14	160	200	125	95	280	212	18	-	87	94	118	130	225
65-200/...	80	65	100	154	177	65	14	180	225	125	95	320	250	18	-	90	97	121	133	275
80-160/...	100	80	125	153	192	65	14	180	225	125	95	320	250	18	-	96	103	127	139	225

1) DN = EN 1092-2/DN../PN 16/21/B

2) in addition observe Ød₁

Dimensions of pump set

Pump size	Motor size																									
	12/22									42/52						72/112/152										
	Baugröße	c ₁	c ₂	f	g ₁	g ₂	m _d	v	l	c ₁	c ₂	f	g ₁	g ₂	m _d	v	l	c ₁	c ₂	f	g ₁	g ₂	m _d	v	l	
32-125.1/...	561	512	409	72	23	170	187	84	695	634	529	86	25	210	235	112	-	-	-	-	-	-	-	-	-	-
32-160.1/...	561	512	409	72	23	170	187	84	695	634	529	86	25	210	235	112	787	730	621	86	29	240	251	112	112	
32-200.1/...	-	-	-	-	-	-	-	-	695	634	529	86	25	210	235	112	787	730	621	86	29	240	251	112	112	
32-250.1/...	-	-	-	-	-	-	-	-	715	654	529	86	25	210	235	112	807	750	621	86	29	240	251	112	112	
32-125/...	561	512	409	72	23	170	187	84	695	634	529	86	25	210	235	112	-	-	-	-	-	-	-	-	-	
32-160/...	561	512	409	72	23	170	187	84	695	634	529	86	25	210	235	112	787	730	621	86	29	240	251	112	112	
32-200/...	-	-	-	-	-	-	-	-	695	634	529	86	25	210	235	112	787	730	621	86	29	240	251	112	112	
32-250/...	-	-	-	-	-	-	-	-	715	654	529	86	25	210	235	112	807	750	621	86	29	240	251	112	112	
40-125/...	561	512	409	72	23	170	187	84	695	634	529	86	25	210	235	112	-	-	-	-	-	-	-	-	-	
40-160/...	561	512	409	72	23	170	187	84	695	634	529	86	25	210	235	112	787	730	621	86	29	240	251	112	112	
40-200/...	-	-	-	-	-	-	-	-	715	654	529	86	25	210	235	112	807	750	621	86	29	240	251	112	112	
40-250/...	-	-	-	-	-	-	-	-	715	654	529	86	25	210	235	112	807	750	621	86	29	240	251	112	112	
50-125/...	581	532	409	72	23	170	187	84	715	654	529	86	25	210	235	112	807	750	621	86	29	240	251	112	112	
50-160/...	581	532	409	72	23	170	187	84	715	654	529	86	25	210	235	112	807	750	621	86	29	240	251	112	112	
50-200/...	-	-	-	-	-	-	-	-	715	654	529	86	25	210	235	112	807	750	621	86	29	240	251	112	112	
65-125/...	581	532	409	72	23	170	187	84	715	654	529	86	25	210	235	112	807	750	621	86	29	240	251	112	112	
65-160/...	-	-	-	-	-	-	-	-	715	654	529	86	25	210	235	112	807	750	621	86	29	240	251	112	112	
65-200/...	-	-	-	-	-	-	-	-	715	654	529	86	25	210	235	112	807	750	621	86	29	240	251	112	112	
80-160/...	-	-	-	-	-	-	-	-	740	679	529	86	25	210	235	112	832	775	621	86	29	240	251	112	112	

Pump connections

Connections	Pump size	Description
1 M	32-.../...	Pressure gauge connection
	40-.../...	
	50-.../...	
	65-.../...	
6 B	80-.../...	Casing drain
	Material variant	
	G	S
6 D	Rc 3/8	G ^{3/8}
	Rc 3/8	G ^{3/8}
	Rc 3/8	G ^{3/8}

Rc = ISO 7/1 G = ISO 228/1

Motor connections

Connections	Motor sizes		Description
	12/22	42/52/72/112/152	
6 B.4	G 3/8	G 3/8	Motor drain
10 E	G 1/4	G 1/4	Barrier fluid inlet
11 E	G 3/8	G 3/8	Flushing liquid inlet
11 E.3	G 1/4	G 1/4	Flushing liquid inlet or sealing liquid inlet
KV.1	PG 21	PG 29	Terminal box version Electrical connection - power cable
KV.2	PG 11	PG 11	Terminal box version Electrical connection - auxiliary cable
KV.3	PG 16	PG 21 (DS 112)	Variant free cable end

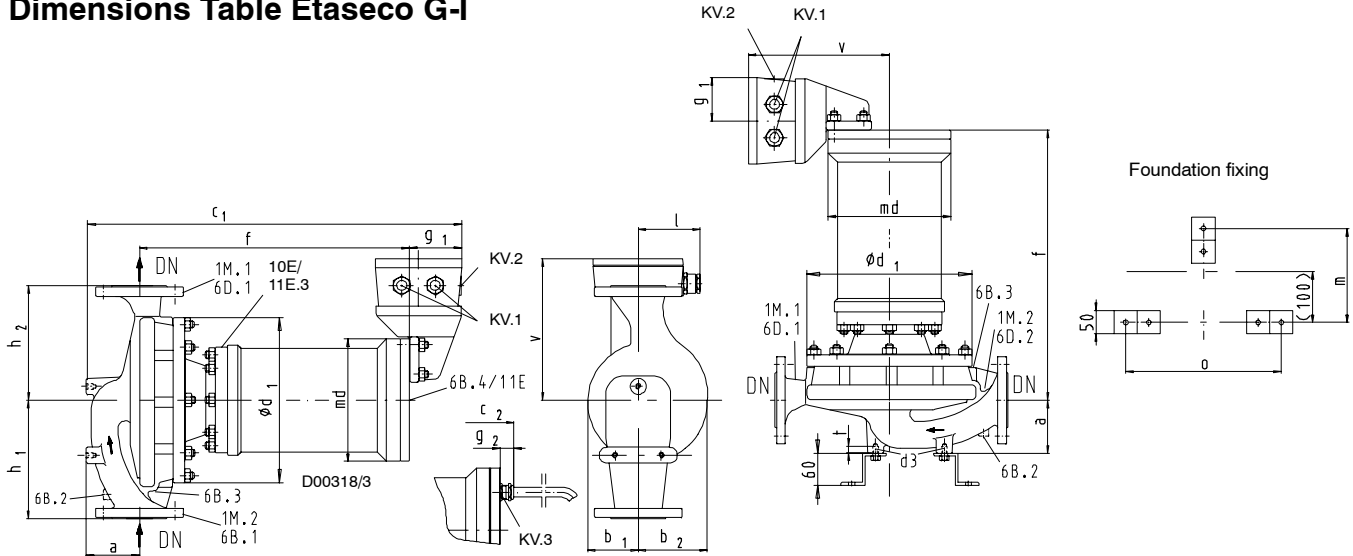
Dimensions Table Etaseco G-I

Pump dimensions

Dimensions in mm

Pump size	Pump dimensions											Total weight (approx., kg)					Motor size	Ød ₁ ⁺³
	DN ¹⁾	a	b ₁	b ₂	d ₃	h ₁	h ₂	t	m	o	12/22	42	52	72/112	152			
32-160/...	32	69	112	120	M10	160	160	12,5	175	190	53	75	82	106	118	225		
32-200/...	32	95	129 ²⁾	135 ²⁾	M10	190	190	12,5	175	190	-	81	88	112	124	275		
40-160/...	40	80	112	119	M10	160	160	12,5	175	190	54	76	83	107	119	225		
40-250/...	40	95	161	168	M10	220	220	12,5	175	190	-	89	96	120	132	320		
50-160/...	50	85	113	125	M10	170	170	12,5	175	190	57	79	86	110	122	225		
50-250/...	50	100	160	175	M10	220	220	12,5	175	210	-	93	100	124	136	320		
65-160/...	65	100	113	125	M10	170	170	12,5	175	210	59	81	88	112	124	225		
65-250/...	65	105	167	190	M10	225	250	12,5	175	230	-	98	105	129	141	320		
80-160/...	80	97	113	135	M10	180	180	12,5	175	230	-	87	94	118	130	225		
80-210/...	80	151	140	160	M10	250	250	12,5	195	230	-	96	103	127	139	275		
100-160/...	100	118	114	144	M10	250	200	12,5	195	230	-	91	98	122	134	225		

1) DN = EN 1092-2/DN.../PN 16/21/B

 2) in addition observe Ød₁

can be mounted with three angle steel feet

Dimensions of pump set

Pump size	Motor size																									
	12/22									42/52									72/112/152							
Baugröße	c ₁	c ₂	f	g ₁	g ₂	m _d	v	l	c ₁	c ₂	f	g ₁	g ₂	m _d	v	l	c ₁	c ₂	f	g ₁	g ₂	m _d	v	l		
32-160/...	568	519	427	72	23	170	187	84	702	641	547	86	25	210	235	112	794	737	639	86	29	240	251	112		
32-200/...	-	-	-	-	-	-	-	-	721	660	540	86	25	210	235	112	814	757	633	86	29	240	251	112		
40-160/...	577	528	425	72	23	170	187	84	711	650	545	86	25	210	235	112	804	747	638	86	29	240	251	112		
40-250/...	-	-	-	-	-	-	-	-	721	660	540	86	25	210	235	112	814	757	633	86	29	240	251	112		
50-160/...	587	538	430	72	23	170	187	84	721	660	550	86	25	210	235	112	813	756	642	86	29	240	251	112		
50-250/...	-	-	-	-	-	-	-	-	730	669	544	86	25	210	235	112	822	765	636	86	29	240	251	112		
65-160/...	606	557	434	72	23	170	187	84	740	679	554	86	25	210	235	112	832	775	646	86	29	240	251	112		
65-250/...	-	-	-	-	-	-	-	-	745	684	554	86	25	210	235	112	837	780	646	86	29	240	251	112		
80-160/...	-	-	-	-	-	-	-	-	746	685	563	86	25	210	235	112	839	782	656	86	29	240	251	112		
80-210/...	-	-	-	-	-	-	-	-	765	704	528	86	25	210	235	112	857	800	620	86	29	240	251	112		
100-160/...	-	-	-	-	-	-	-	-	762	701	558	86	25	210	235	112	854	797	650	86	29	240	251	112		

Pump connections

Connections	Pump sizes		Description
	32-.../...	100-.../...	
1 M.1/2	Rc 3/8	Rc 1/2	Pressure gauge connection
6 B.1/.2 ²⁾ /3	Rc 3/8	Rc 1/2	Casing drain
6 D.1/2	Rc 3/8	Rc 1/2	Casing - priming and venting

Rc = ISO 7/1

2) 6B.2 only on pump sizes 80-120, 100-125 and 100-160

Motor connections

Connections	Motor sizes		Description
	12/22	42/52/72/112/152	
6 B.4	G 3/8	G 3/8	Motor drain
10 E	G 1/4	G 1/4	Barrier fluid inlet
11 E	G 3/8	G 3/8	Flushing liquid inlet
11 E.3	G 1/4	G 1/4	Flushing liquid inlet or sealing liquid inlet
KV.1	PG 21	PG 29	Terminal box version Electrical connection - power cable
KV.2	PG 11	PG 11	Terminal box version Electrical connection - auxiliary cable
KV.3	PG 16	PG 21 (DS 112)	Variant free cable end

G = ISO 228/1

PG = DIN 40430

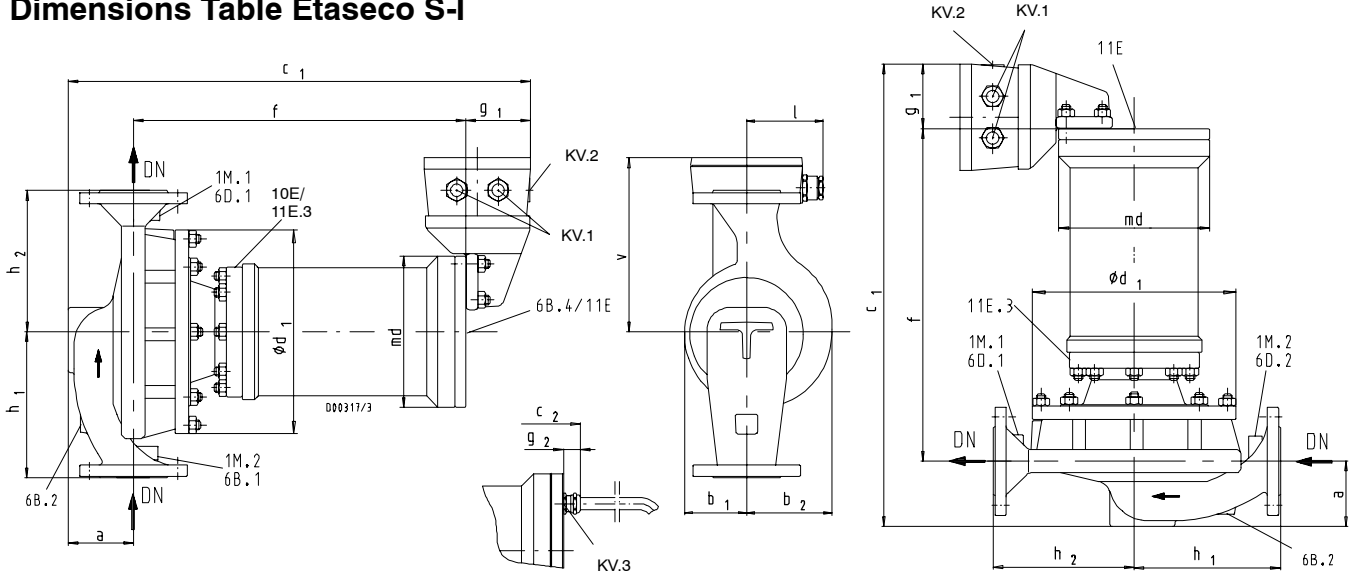
Dimensions Table Etaseco S-I

Pump dimensions

Dimensions in mm

Pump size	Pump dimensions						Total weight (approx.. kg)						Ød ₁ + ³
	DN ¹⁾	a	b ₁	b ₂	h ₁	h ₂	Motor size						
40-160/...	40	75	113	113	155.0	165.0	54	76	83	107	119	225	
40-200/...	40	85	136 ²⁾	136 ²⁾	180.0	210.0	-	82	89	113	125	275	
50-160/...	50	78	113	120	160.0	180.0	56	78	85	109	121	225	
50-200/...	50	91	138	138	205.0	220.0	-	85	92	116	128	275	
65-160/...	65	100	113	118	160.0	180.0	59	81	88	112	124	225	
65-200/...	65	102	136 ²⁾	138	240.0	235.0	-	90	97	121	133	275	
80-160/...	80	108	113	128	180.0	180.0	64	87	94	118	130	225	
80-200/...	80	136	138	154	262.5	237.5	-	91	98	122	134	275	
100-160/...	100	114	114	144	250.0	200.0	-	92	99	123	135	225	

1) DN = EN 1092-2/DN../PN 16/21/B

 2) in addition observe Ø d₁
Dimensions of pump set

Pump size	Motor size																							
	12/22								42/52								72/112/152							
	c ₁	c ₂	f	g ₁	g ₂	m _D	v	l	c ₁	c ₂	f	g ₁	g ₂	m _D	v	l	c ₁	c ₂	f	g ₁	g ₂	m _D	v	l
Baugröße																								
40-160/...	567	590	420	72	23	170	187	84	702	641	541	86	25	210	235	112	794	737	633	86	29	240	251	112
40-200/...	-	-	-	-	-	-	-	-	719	658	548	86	25	210	235	112	811	754	640	86	29	240	251	112
50-160/...	575	598	425	72	23	170	187	84	710	649	546	86	25	210	235	112	802	745	638	86	29	240	251	112
50-200/...	-	-	-	-	-	-	-	-	723	662	546	86	25	210	235	112	816	759	639	86	29	240	251	112
65-160/...	606	629	434	72	23	170	187	84	740	679	554	86	25	210	235	112	833	776	647	86	29	240	251	112
65-200/...	-	-	-	-	-	-	-	-	730	669	542	86	25	210	235	112	822	765	634	86	29	240	251	112
80-160/...	616	639	436	72	23	170	187	84	750	689	556	86	25	210	235	112	843	786	649	86	29	240	251	112
80-200/...	-	-	-	-	-	-	-	-	751	690	529	86	25	210	235	112	843	786	621	86	29	240	251	112
100-160/...	-	-	-	-	-	-	-	-	758	697	558	86	25	210	235	112	736	679	650	86	29	240	251	112

Pump connections

Connections	Pump sizes		Description
	40-.../...	100-.../...	
	50-.../...		
	65-.../...		
	80-.../...		
1 M.1/2	G 3/8	G 1/2	Pressure gauge connection
6 B.1/2 ²⁾	G 3/8	G 1/2	Casing drain
6 D.1/2	G 3/8	G 1/2	Casing - priming and venting

2) 6B.2 only on pump sizes 80-200 and 100-160

Motor connections

Connections	Motor sizes		Description
	12/22	42/52/72/112/152	
6 B.4	G 3/8	G 3/8	Motor drain
10 E	G 1/4	G 1/4	Barrier fluid inlet
11 E	G 3/8	G 3/8	Flushing liquid inlet
11 E.3	G 1/4	G 1/4	Flushing liquid inlet or sealing liquid inlet
KV.1	PG 21	PG 29	Terminal box version Electrical connection - power cable
KV.2	PG 11	PG 11	Terminal box version Electrical connection - auxiliary cable
KV.3	PG 16	PG 21 (DS 112)	Variant free cable end

 G = ISO 228/1
 PG = DIN 40430

Motors DS 90 (motor sizes 12 and 22) with SSiC bearings

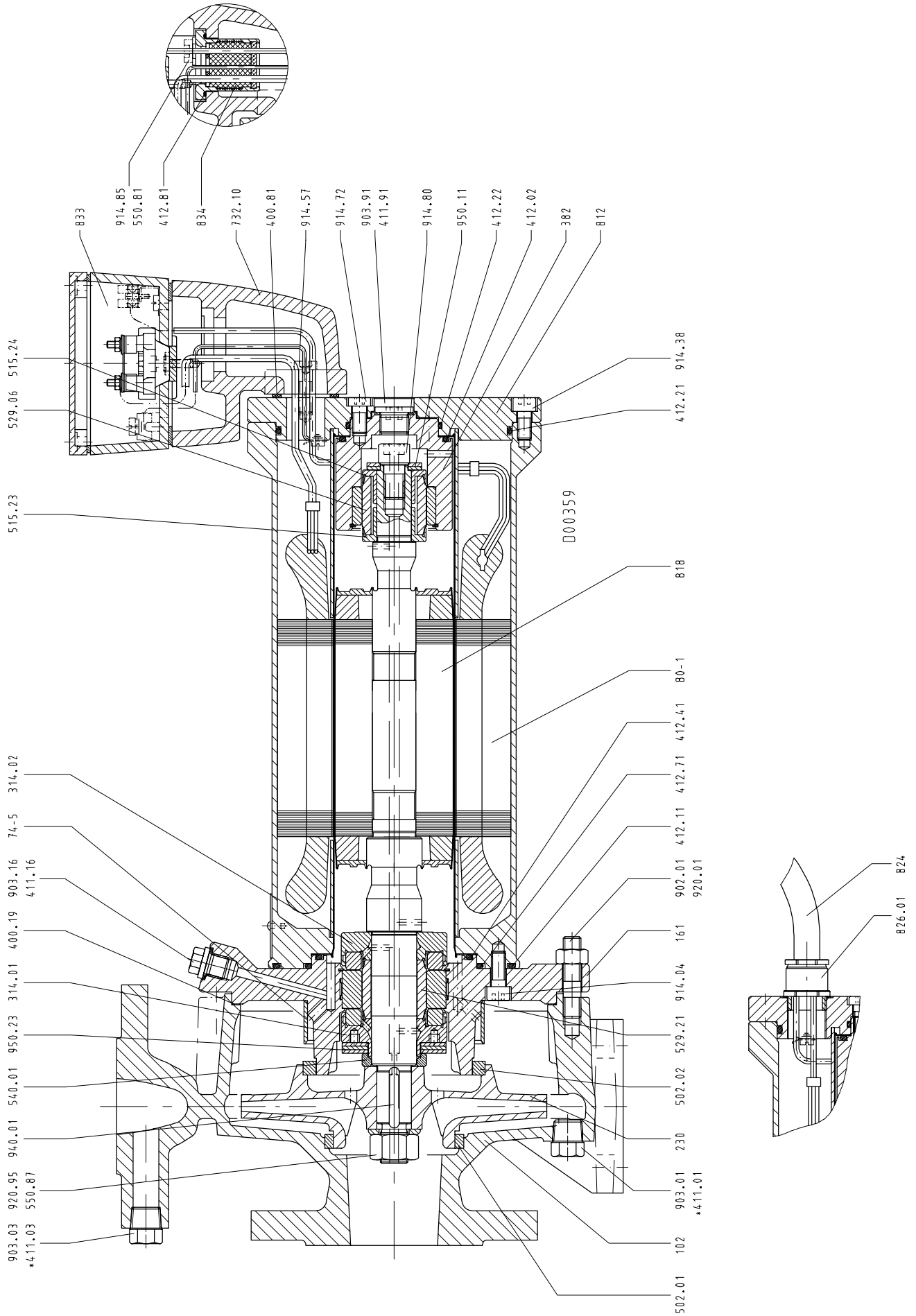

When ordering spare parts please always specify the type series/pump size, works No. (stamped on the name plate and on the suction nozzle flange), motor No. (serial No.), year of construction, quantity required, part No., part description, material, medium handled, sectional drawing No. and mode of dispatch.

Part No.	Part description	Scope of supply
102	Volute casing	with joint ring 411.01/03, casing wear ring 502.01, stud 902.01, screwed plug 903.01/03, hex. nut 920.01
161	Casing cover	with bearing bush, gasket 400.19, joint ring 411.16, separator 74-5, screwed plug 903.16
230	Impeller	with casing wear ring 502.02
310.10	Plain bearing, pump end	consisting of thrust bearing 314.01/02, bearing sleeve 529.21, cup spring 950.23
310.11	Plain bearing, motor end	consisting of taper lock ring 515.23/24, bearing sleeve 529.06, socket head cap screw 914.80, cup spring 950.11
382	Bearing carrier	with bearing bush, joint ring 411.91, screwed plug 903.91, socket head cap screw 914.72
80-1	Motor unit	with O-ring 412.21/22, cover 812, support, stator, motor housing, can, socket head cap screw 914.04/38
818	Rotor	with bush 540.01, key 940.01
834	Sealed terminal gland ¹⁾	with disc 550.81, socket head cap screw 914.85
920.95	Hex. nut	with disc 550.87
99-9	Set of sealing elements	consisting of 400.19/81, 411.01/03/16/91, 412.02/11/21/22/41/71/81
	Terminal box ¹⁾	consisting of gasket 400.81, O-ring 412.81, holder 732.10, terminal box 833, socket head cap screw 914.57
	Cable gland ¹⁾	consisting of cable 824, cable gland 826.01

1) if fitted

Motors DS 112 (motor sizes 42 and 52) and DS 132 (motor sizes 72, 112 and 152) with SSiC bearings

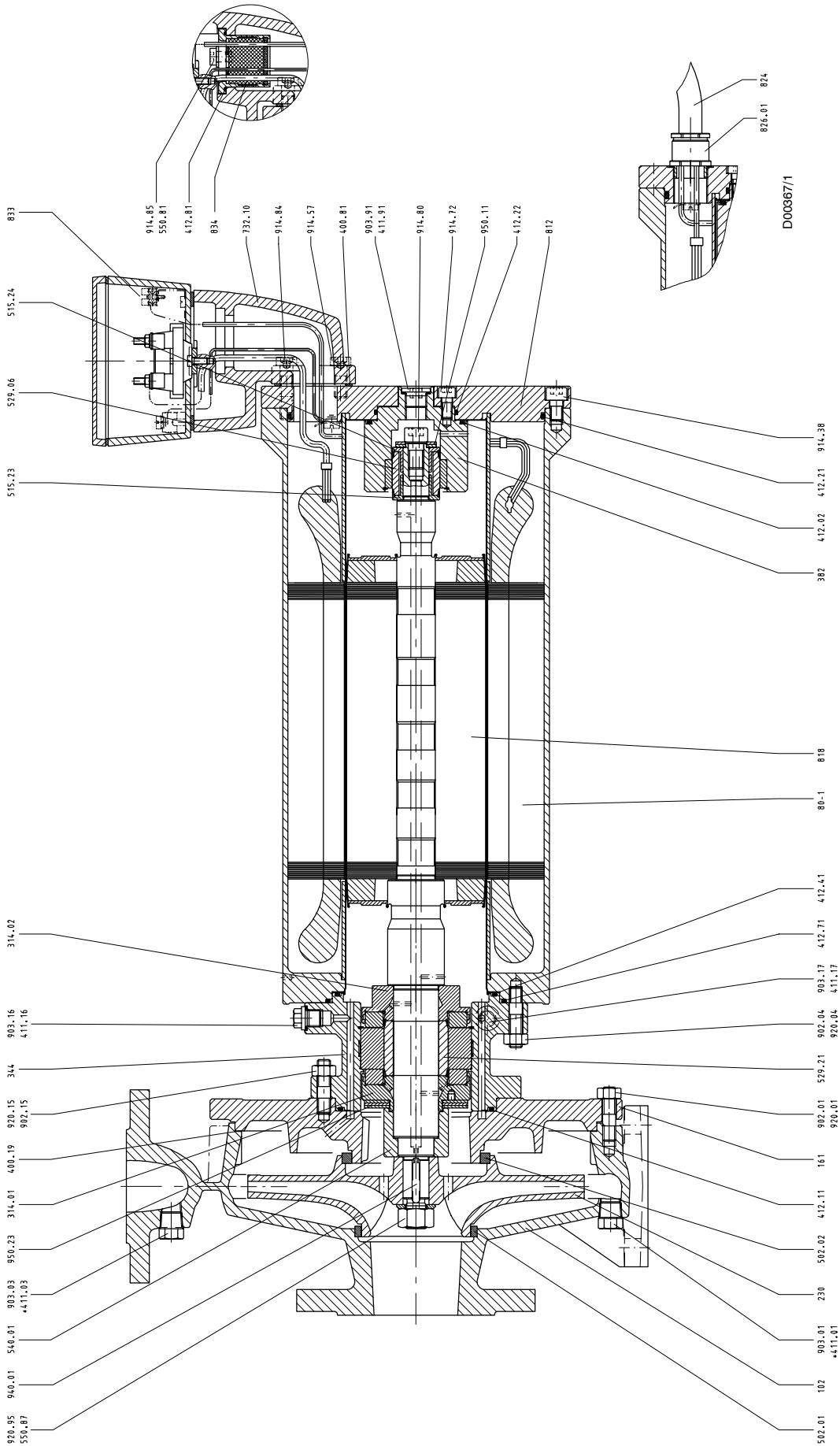

When ordering spare parts please always specify the type series/pump size, works No. (stamped on the name plate and on the suction nozzle flange), motor No. (serial No.), year of construction, quantity required, part No., part description, material, medium handled, sectional drawing No. and mode of dispatch.

Part No.	Part description	Scope of supply
102	Volute casing	with joint ring 411.01/.03, casing wear ring 502.01, stud 902.01, screwed plug 903.01/.03, hex. nut 920.01
161	Casing cover	with gasket 400.19, stud 902.15, nut 920.15
230	Impeller	with casing wear ring 502.02
310.10	Plain bearing, pump end	consisting of thrust bearing 314.01/.02, bearing sleeve 529.21, cup spring 950.23
310.11	Plain bearing, motor end	consisting of taper lock ring 515.23/.24, bearing sleeve 529.06, socket head cap screw 914.80, cup spring 950.11
344	Bearing bracket lantern	with bearing bush, joint ring 411.16, screwed plug 903.16
382	Bearing carrier	with bearing bush, joint ring 411.91, screwed plug 903.91, socket head cap screw 914.72
80-1	Motor unit	with support, stator, motor housing, can, O-ring 412.21/.22/.41/.71, cover 812, stud 902.04, socket head cap screw 914.38, nut 920.04
818	Rotor	with bush 540.01, key 940.01
834	Sealed terminal gland ¹⁾	with disc 550.81, socket head cap screw 914.85
920.95	Hex. nut	with disc 550.87
99-9	Set of sealing elements	consisting of 400.19/.81, 411.01/.03/.16/.17/.91, 412.02/.11/.21/.22/.41/.71/.81
	Terminal box ¹⁾	consisting of gasket 400.81, O-ring 412.81, holder 732.10, terminal box 833, socket head cap screw 914.57/.84
	Cable gland ¹⁾	consisting of cable 824, cable gland 826.01

1) if fitted

