

**CAST IRON PN16 FLANGES STRAINER FOR HIGH TEMPERATURE**



ISO 9001  
BUREAU VERITAS  
Certification



CE

PGT

**Size :** DN 15 to DN 200  
**Ends :** Flanges R.F. GN10/16  
**Min Temperature :** - 10°C  
**Max Temperature :** + 300°C  
**Max Pressure :** 16 Bars  
**Specifications :** Stainless steel removable filter  
Bolted bonnet with draining cap

**Materials :** Cast iron EN GJL-250

**CAST IRON PN16 FLANGES STRAINER FOR HIGH TEMPERATURE**
**SPECIFICATIONS :**

- Stainless steel removable filter
- Flanges R.F. GN10/16 up to DN150 , GN16 for DN200
- Horizontal or vertical position with descendant fluid (respect the flow direction indicated by the arrow)
- Mesh 1mm up to DN 50 , 1.25 mm from DN 65 to 80 and 1.6 mm over
- Bolted bonnet with draining cap threaded BSP

**USE :**

- For all common fluids
- Min Temperature Ts : - 10°C
- Max Temperature Ts :+ 300°C
- Max Pressure PN : 16 bars ( see graph )
- **Steam : 10 bars max.**

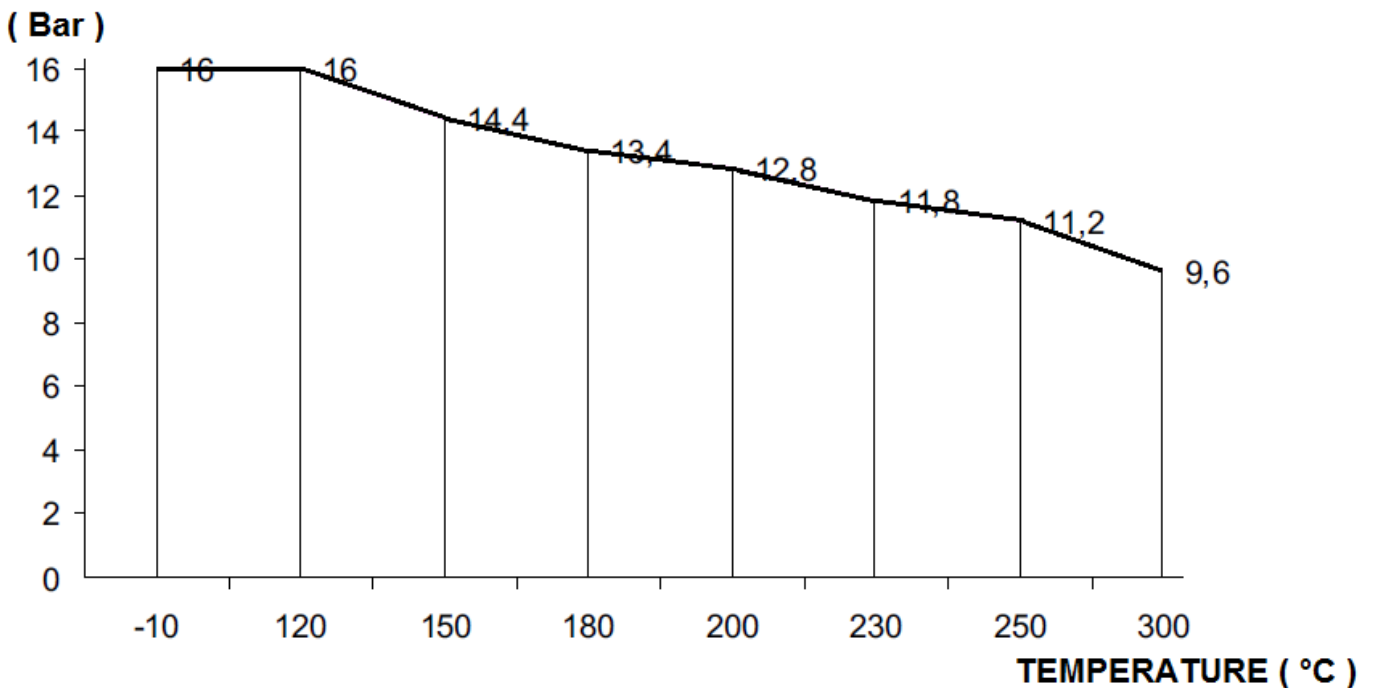
**PRESSURE / TEMPERATURE GRAPH ( STEAM EXCLUDED ) :**

**FLOW COEFFICIENT Kv ( M3 / h ) :**

DN	15	20	25	32	40	50	65	80	100	125	150	200
Kv ( m3/h )	5.7	10.4	16.4	27.3	42	64.7	98	149	234	376	454	853

**CAST IRON PN16 FLANGES STRAINER FOR HIGH TEMPERATURE**

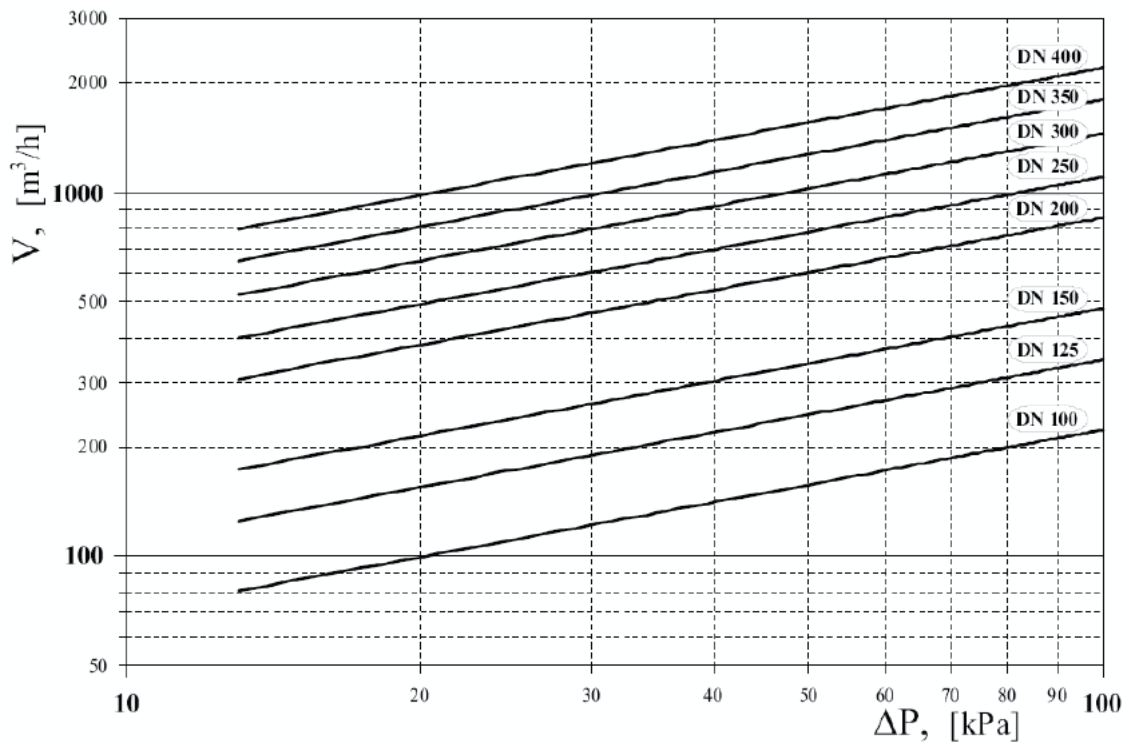
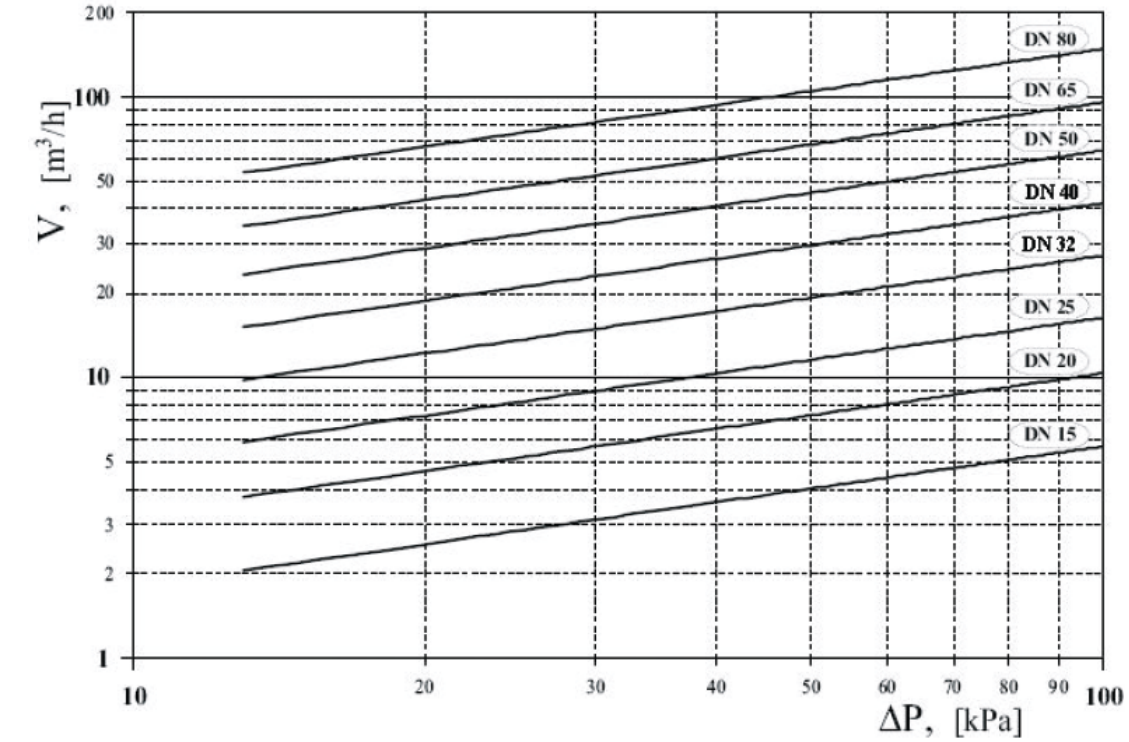
HEAD LOSS GRAPH :



**CAST IRON PN16 FLANGES STRAINER FOR HIGH TEMPERATURE**

**RANGE :**

- Cast iron strainer flanged R. F. GN10/16 from DN 15 to DN 150 and GN16 for DN200 **Ref.236**

**MATERIALS :**

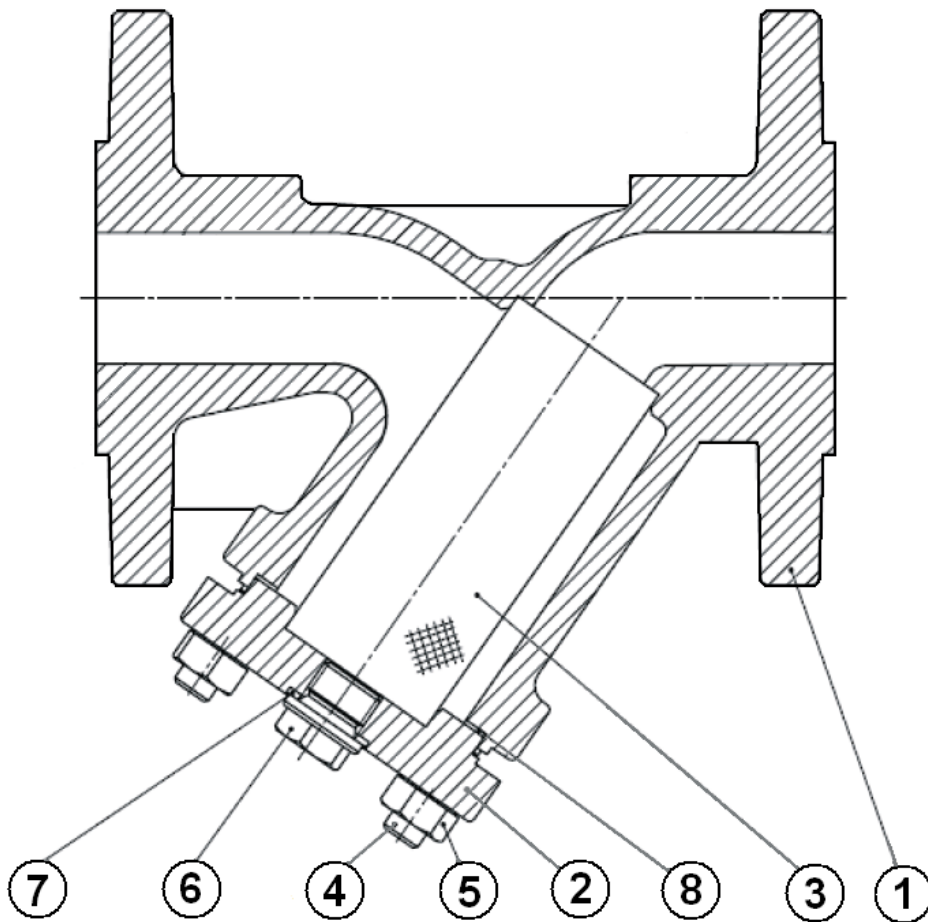

Item	Designation	Materials
1	Body	Cast iron EN GJL-250
2	Bonnet	Cast iron EN GJL-250
3	Filter	ASTM A182 F 304
4	Studs	8.8-A2A
5	Nut	8-A2A
6	Draining cap	C35E
7	Draining gasket	A4 1.4571
8	Bonnet gasket	Graphite

**CAST IRON PN16 FLANGES STRAINER FOR HIGH TEMPERATURE**

SIZE ( in mm ) :

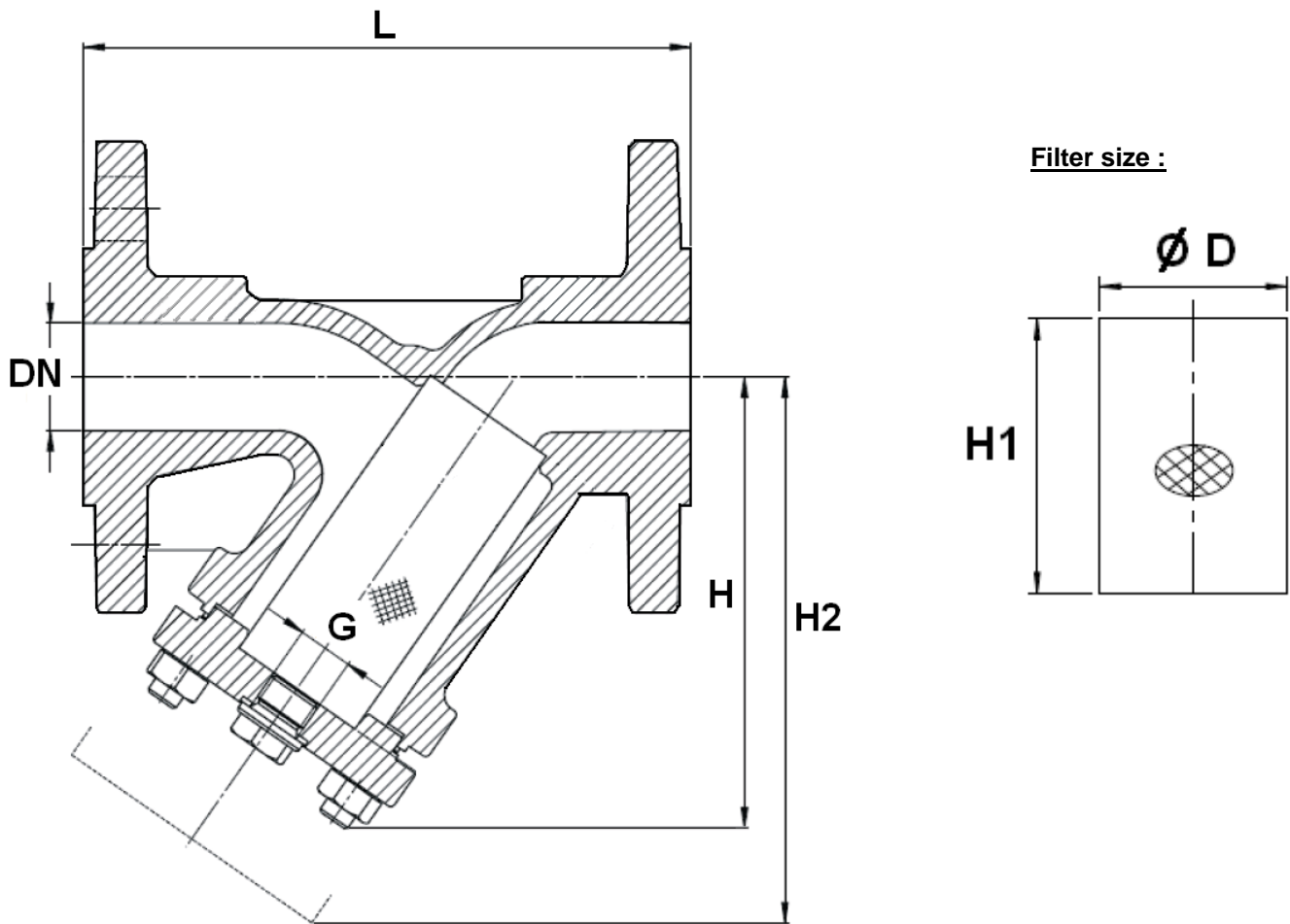

Ref.	DN	15	20	25	32	40	50	65	80	100	125	150	200
236	L	130	150	160	180	200	230	290	310	350	400	480	600
	H	90	100	115	135	150	155	175	205	275	325	397	535
	H2	135	150	180	215	240	250	285	330	365	425	480	610
	G ( Drain.cap )	3/8"	3/8"	3/4"	3/4"	1"	1"	1"	1"	1"1/2	1"1/2	1"1/2	1"1/2
	Ø D	23	28	36	42	50	61.5	78.5	89.5	109.5	137.5	160	210
	H1	56	68	82	98	114	119	134	149	169	199	224	284
	Mesh	1	1	1	1	1	1	1.25	1.25	1.6	1.6	1.6	1.6
	Weight ( Kg )	2.6	3	4.3	6.8	8.8	11	14.6	18.6	27	38.5	54.5	110

**CAST IRON PN16 FLANGES STRAINER FOR HIGH TEMPERATURE**

FLANGES SIZE ( in mm ) :

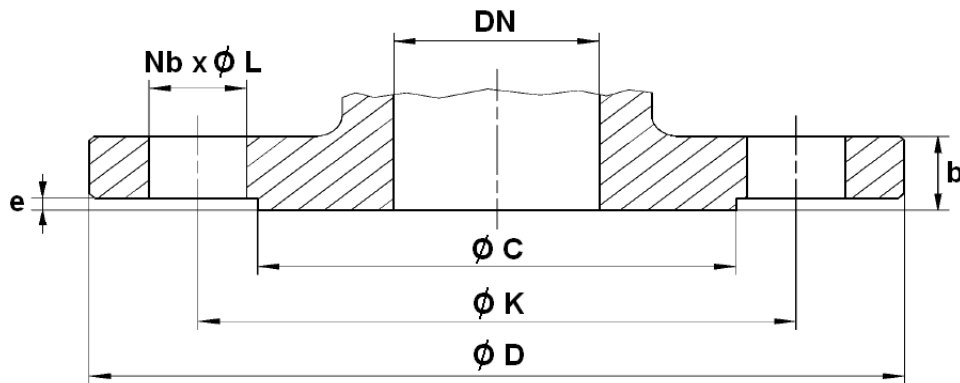

DN	15	20	25	32	40	50	65	80	100	125	150	200
Ø C	46	56	65	76	84	99	118	132	156	184	211	266
Ø D	95	105	115	140	150	165	185	200	220	250	285	340
Ø K	65	75	85	100	110	125	145	160	180	210	240	295
Nb x Ø L	4 x 14	4 x 14	4 x 14	4 x 19	4 x 19	4 x 19	4 x 19	8 x 19	8 x 19	8 x 19	8 x 23	12 x 23
b	16	18	18	18	18	20	18	20	20	22	22	24
e	2	2	2	2	2	2	2	2	2	2	2	2

## **CAST IRON PN16 FLANGES STRAINER FOR HIGH TEMPERATURE**

### STANDARDS :

- Fabrication according to ISO 9001 : 2008
- DIRECTIVE 97/23/CE : CE N° 0062  
Risk category I from DN32 to DN80  
Risk category II from DN100 to DN200
- Test according to EN 12266-1
- Length according to EN 558-1 Series 1 ( DIN 3202 F1 – NF 29354 )
- Approval certificate Russian Federation **GOST-R**
- Flanges R.F. according to EN 1092-2 PN16

### INSTALLATION POSITIONS :

Vertical position ( descendand fluid )

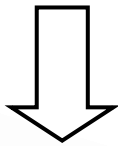

Horizontal position

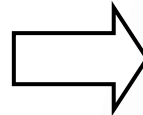

**ADVICE :** Our opinion and our advice are not guaranteed and SFERACO shall not be liable for the consequences of damages.  
The customer must check the right choice of the products with the real service conditions.

**CAST IRON PN16 FLANGES STRAINER FOR HIGH TEMPERATURE****INSTALLATION INSTRUCTIONS****GENERAL GUIDELINES :**

- Ensure that the strainers to be used are appropriate for the conditions of the installation (type of fluid, pressure and temperature).
- Be sure to have enough valves to be able to isolate the sections of piping as well as the appropriate equipment for maintenance and repair.
- Ensure that the strainers to be installed are of correct strength to be able to support the capacity of their usage.
- **Installation of all circuits should ensure that their function can be automatically tested on a regular basis (at least two times a year).**

**INSTALLATION INSTRUCTIONS :**

- **Before installing the strainers, clean and remove any objects from the pipes** (in particular bits of sealing and metal) which could obstruct and block the strainers.
- **Ensure that both connecting pipes either side of the strainer (upstream and downstream) are aligned (if they're not, the strainer may not work correctly).**
- **Make sure that the two sections of the pipe (upstream and downstream) match, the strainer unit will not absorb any gaps. Any distortions in the pipes may affect the tightness of the connection, the working of the strainer and can even cause a rupture.** To be sure, place the kit in position to ensure the assembling will work.
- Make sure flanges are cleaned.
- **If sections of piping do not have their final support in place, they should be temporarily fixed. This is to avoid unnecessary strain on the strainer.**
- Tighten the bolts in cross.
- The pressurisation must be increased gradually.
- So that the maintenance operations could be easily done, place a stop valve before and after the strainer. Thereby, the strainer could be isolated. During this operation, ensure to have a new bonnet gasket to avoid a leakage during the restarting.
- **Fluids in the strainer must not contain solid objects ( it could damaged the seat ).**