

CAST IRON FLANGED Y STRAINER PN16 TYPE 225

MAIN FEATURES

The cast iron Y strainer type 225 is dedicated to the protection of the all kinds sensible valves like automatic valves, pressure reducing valve, steam traps, The plug allows the connection of a drain valve. This strainer can be used on all usual industrial fluids like water, oil and steam. The face to face dimension of the 225 strainer is standardized according to EN 558.

AVAILABLE MODELS

Sizes DN15 to DN200, flanged connection according to PN16



LIMITS OF USE

Fluid pressure : PS	16 bar
Fluid temperature : TS	-10°C / +300°C

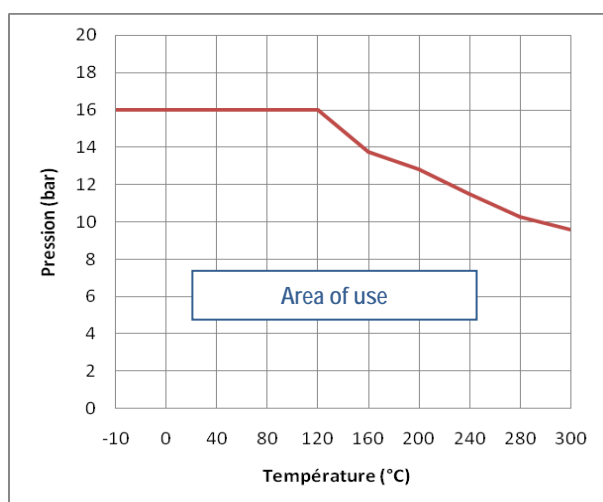

REGULATION AND STANDARDS OF CONSTRUCTION

	Standard	NB		Standard
P.E.D. 97/23	DN15 to DN25 : excluded		Final test	EN 12266-1
	DN32 to DN200 : category III	BV 0062	Material certificate	EN 10204
Flanges dimensions	EN 1092-2		Face to face dimension	EN 558-1 range 1

SCREENING RANGES

Size	Standard	Option
DN15 to DN50	F45 / mesh 1,00 mm / 45 mesh/cm ²	mesh 0,63 mm / 100 mesh/cm ² mesh 0,50 mm / 200 mesh/cm ² mesh 0,40 mm / 300 mesh/cm ² mesh 0,32 mm / 400 mesh/cm ² mesh 0,20 mm / 600 mesh/cm ²
DN65 to DN80	F28 / mesh 1,25 mm / 28 mesh/cm ²	
DN100 to DN200	F15 / mesh 1,60 mm / 15 mesh/cm ²	

Informations données à titre indicatif et sous réserve de modifications éventuelles

	SECTORIEL S.A. 45 rue du Ruisseau 38290 SAINT QUENTIN-FALLAVIER – FRANCE Tél : +33 4 74 94 90 70 – Fax : +33 4 74 94 13 95 www.sectoriel.fr / courrier : sectoriel@sectoriel.fr	Nbr. pages	2
		Ref.	FT1650ENG
		Rev.	0
		Date	08/2012

CAST IRON FLANGED Y STRAINER PN16 TYPE 225

CONSTRUCTION

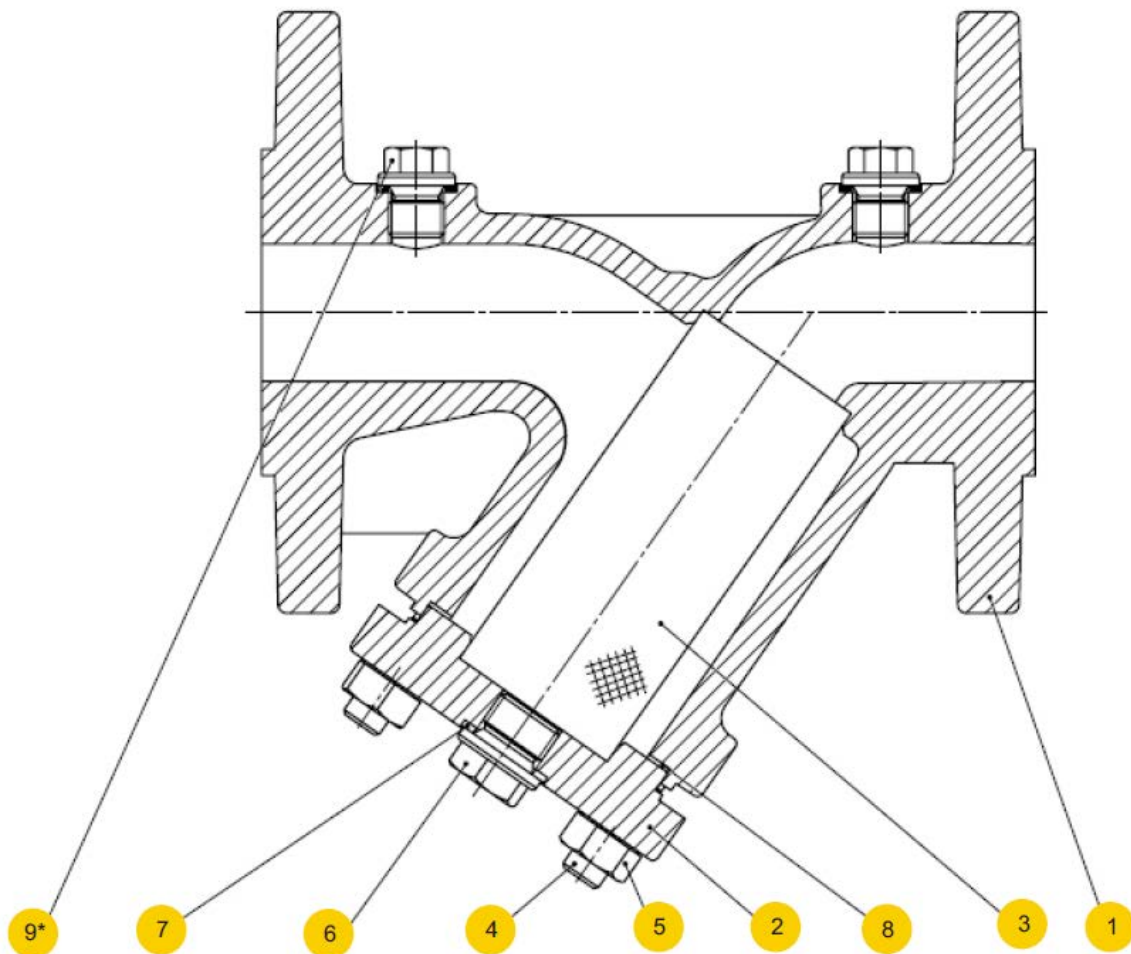

n°	Item	Material
1	Body	Cast iron EN GJL-250 JL 1040
2	Cover	Cast iron EN GJL-250 JL 1040
3	Screen	Stainless steel 1.4301
4	Screw	Carbon steel 8.8-A2A
5	Nut	Carbon steel 8-A2A
6	Drain plug	Carbon steel C35E
7	Drain gasket	Carbon steel 1.4571
8	Cover gasket	Graphite-SS
9	Pressure measuring plug (option)	Carbon steel C35E

Informations données à titre indicatif et sous réserve de modifications éventuelles

	SECTORIEL S.A. 45 rue du Ruisseau 38290 SAINT QUENTIN-FALLAVIER – FRANCE Tél : +33 4 74 94 90 70 – Fax : +33 4 74 94 13 95 www.sectoriel.fr / courrier : sectoriel@sectoriel.fr	Nbr. pages	2
		Ref.	FT1650ENG
		Rev.	0
		Date	08/2012

CAST IRON FLANGED Y STRAINER PN16 TYPE 225

DIMENSIONS (mm)

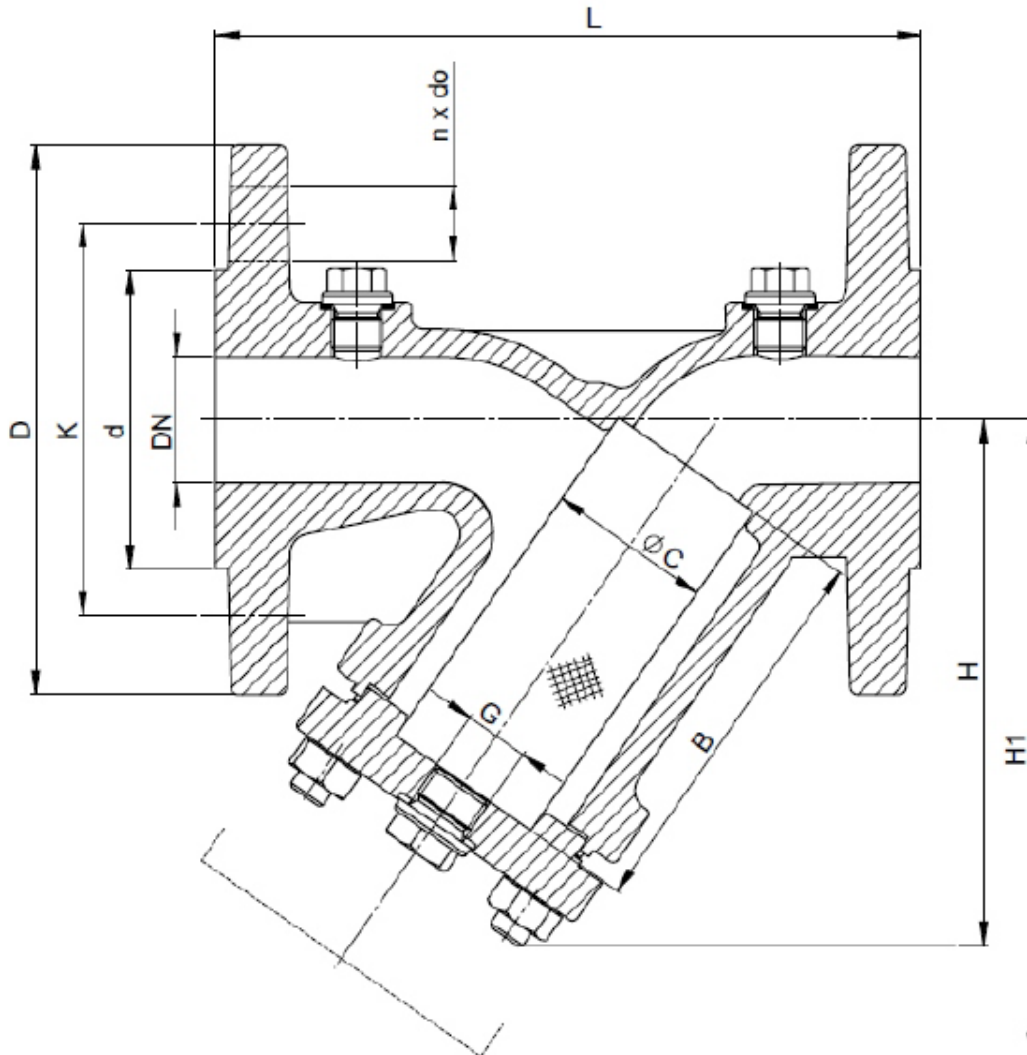

Size	15	20	25	32	40	50	65	80	100	125	150	200
L	130	150	160	180	200	230	290	310	350	400	480	600
D	95	105	115	140	150	165	185	200	220	250	285	340
d	46	56	65	76	84	99	118	132	156	184	211	266
K	65	75	85	100	110	125	145	160	180	210	240	295
N x do	4x14	4x14	4x14	4x19	4x19	4x19	4x19	8x19	8x19	8x19	8x23	12x23
Kv	5.7	10.4	16.4	27.3	42.0	64.7	98.0	149	234	376	454	853
H	90	100	115	135	150	175	175	205	275	325	397	535
H1	135	150	180	215	240	250	285	330	365	425	480	610
G	3/8"	3/8"	3/4"	3/4"	1"	1"	1"	1"	1" 1/2	1" 1/2	1" 1/2	1" 1/2
C	23	28	36	42	50	61.5	78.5	89.5	109.5	137.5	160	210
B	56	68	82	98	114	119	134	149	169	199	224	284
W (kg)	2.6	3.0	4.3	6.8	8.8	11.0	14.6	18.6	27.0	38.5	54.5	110.0

Informations données à titre indicatif et sous réserve de modifications éventuelles

	SECTORIEL S.A. 45 rue du Ruisseau 38290 SAINT QUENTIN-FALLAVIER – FRANCE Tél : +33 4 74 94 90 70 – Fax : +33 4 74 94 13 95 www.sectoriel.fr / courrier : sectoriel@sectoriel.fr	Nbr. pages	2
		Ref.	FT1650ENG
		Rev.	0
		Date	08/2012

CAST IRON FLANGED Y STRAINER PN16 TYPE 225

PRESSURE LOSS FOR WATER

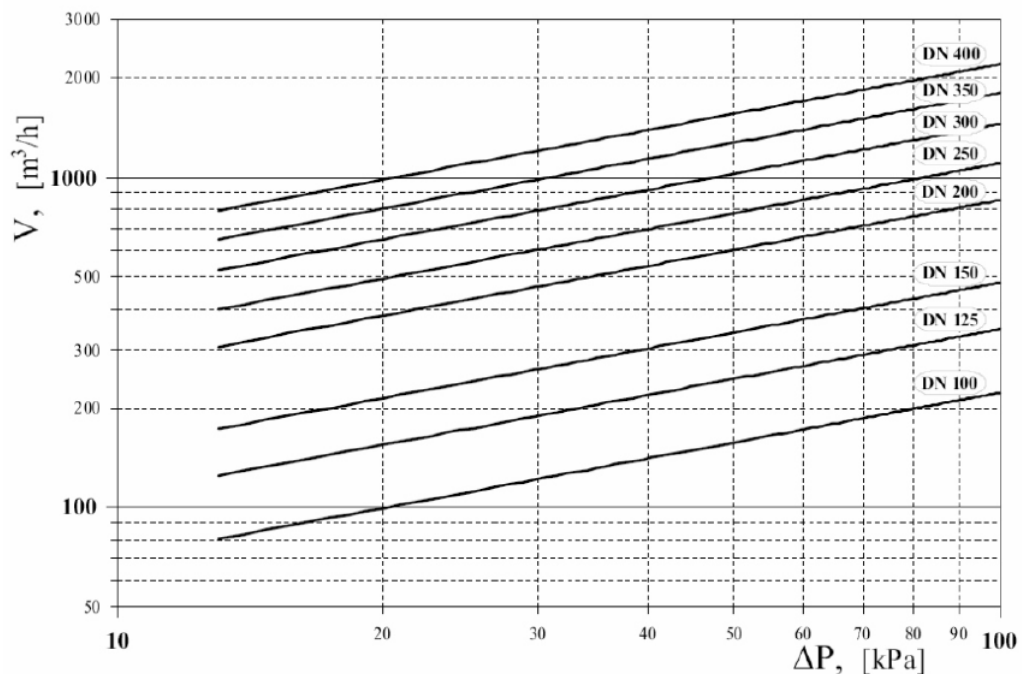
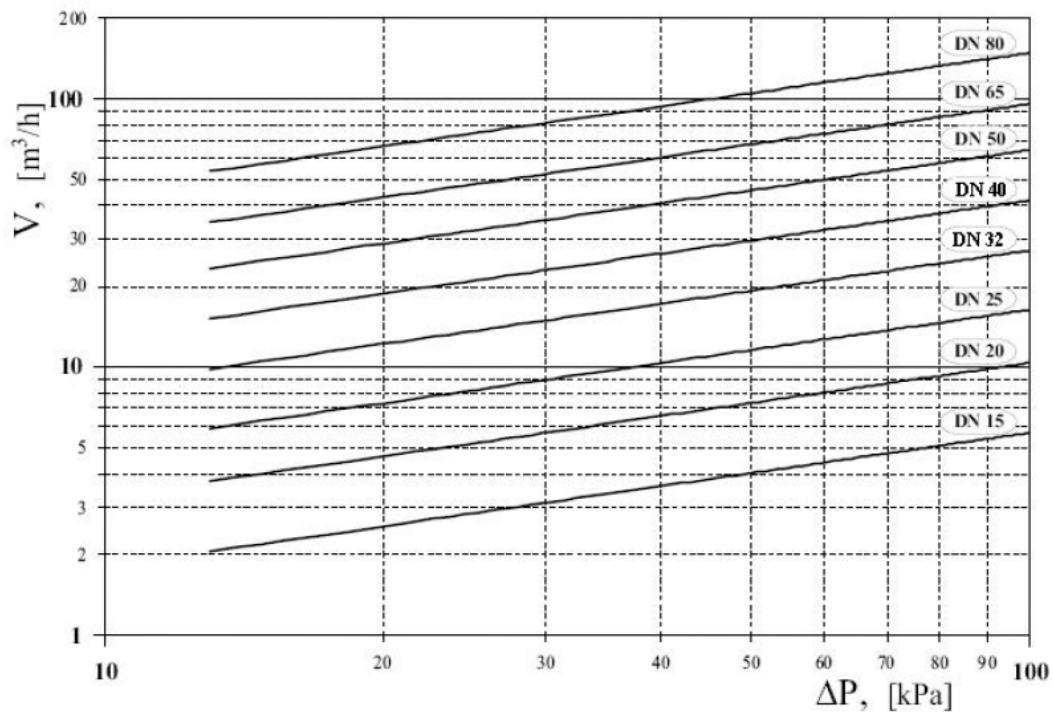

Informations données à titre indicatif et sous réserve de modifications éventuelles

	SECTORIEL S.A. 45 rue du Ruisseau 38290 SAINT QUENTIN-FALLAVIER – FRANCE Tél : +33 4 74 94 90 70 – Fax : +33 4 74 94 13 95 www.sectoriel.fr / courrier : sectoriel@sectoriel.fr	Nbr. pages	2
		Ref.	FT1650ENG
		Rev.	0
		Date	08/2012