

2/2 PILOTED SOLENOID VALVE TYPE ESM86

MAIN CHARACTERISTICS

The ESM 86 solenoid valve is a 2/2 piloted valve dedicated to the shut off of clean and non-aggressive fluids. The operation way is normally closed. The standard construction includes quality brass body and cover, internal parts in stainless steel and diaphragm is NBR. This solenoid valve is also available with several diaphragm materials and various coil voltages. Manufacturing quality is following ISO 9001. Connection is G threaded according to ISO 228/1.



DIFFERENTIAL PRESSURE

Size	Port (mm)	Kv (m3/h)	P max (bar) AC	P max (bar) DC	Operating time
3/8"	10	1,86	10	10	20-60 ms
1/2"	12	2,10	10	10	20-60 ms
3/4"	20	5,70	10	10	20-60 ms
1"	25	9,60	10	10	20-60 ms
1 1/4"	32	22,0	10	10	50 à 80 ms
1 1/2"	39	27,0	10	10	50 à 80 ms
2"	51	35,0	10	10	50 à 80 ms
2 1/2"	65	63,0	10	10	50 à 80 ms
3"	75	83,0	10	10	50 à 80 ms

ELECTRICAL CHARACTERISTICS

Voltage	Frequency	Power consumption	
		Holding	Rush
12V AC	50Hz . 60Hz	11 VA	24 VA
24V AC	50Hz . 60Hz	11 VA	24 VA
48V AC	50Hz . 60Hz	11 VA	24 VA
110V AC	50Hz . 60Hz	11 VA	24 VA
230V AC	50Hz . 60Hz	11 VA	24 VA
400V AC	50Hz . 60Hz	11 VA	24 VA
12V DC		16W	
24V DC		16W	
48V DC		16W	
110V DC		16W	

CLASSIFICATION ACC. TO PED 97/23

A3§3. Use allowed for all standard fluids up to 1" For 1+1/4 and larger sizes, use forbidden on dangerous gas.

LIMITS OF USE

PS : max. working pressure	10 bar
P : min. differential pressure	0,3 bar
TS : max. working temperature (NBR)	90°C
TE : max. ambient temperature	80°C

With DC current and temperature above 40°C, the max. P could be decreased.

PRESSURE LOSS DIAGRAM (BAR)

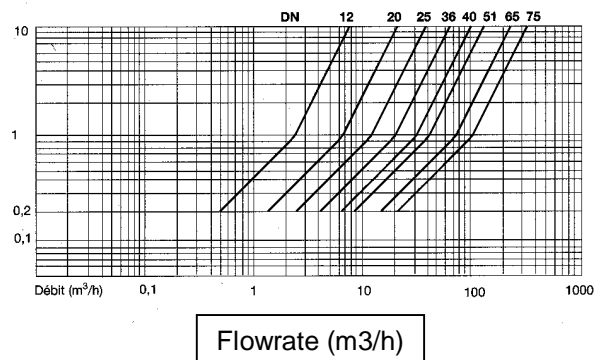

Modifications reserved

2/2 PILOTED SOLENOID VALVE TYPE ESM86

CONSTRUCTION

N°	Item	Material
1	Nut	Zincated carbon steel
2	Washer	Zincated carbon steel
3	Coil	PBT+30% G.F.
4	Tube	Stainless steel AISI 430
5	Plunger	Stainless steel AISI 430
6	Spring	Stainless steel AISI 430
7	Support	Stainless steel AISI 303
8	Gasket	NBR
9	Spring	Carbon steel
10	Screw	Stainless steel
11	Cover	Brass EN CW 617 N
12	Spring	Carbon steel
13	Diaphragm	NBR
14	Guide	Brass
15	Body	Brass EN CW 617 N

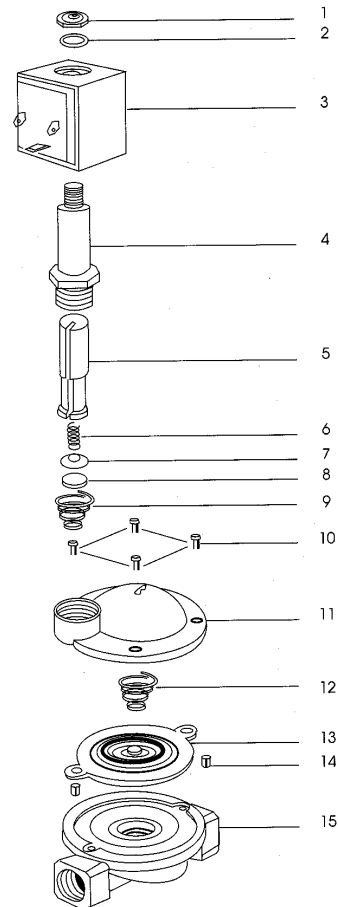

OPTIONS

EPDM diaphragm : 130°C
 EPDM-KTW diaphragm for drinkable water : 130°C
 FPM diaphragm : 150°C
 Coil with IP67 moulded cable
 Timer
 Nut with reinforced gasket for wet areas
 NPT connections

DIMENSIONS

Size	A	B	C	D	W (kg)
3/8"	61	89	48	77	0,54
1/2"	61	89	48	77	0,50
3/4"	87	101	69	84	0,8
1"	100	106	80	86	1,10
1" 1/4	131	122	112	95	2,50
1" 1/2	146	128	128	98	3,00
2"	174	145	146	108	4,60
2" 1/2	245	180	184	134	9,40
3"	250	190	184	139	11,23

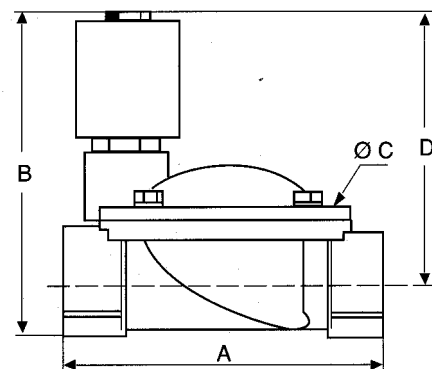

MOUNTING INSTRUCTIONS

ESM86 can be installed in any positions but the vertical position with coil under is not recommended. The solenoid valve has to be protected with a Y strainer. The arrow on the body has to follow the direction of the flow.

Modifications reserved