

C 906

Control valves

Over speed protection

Technical Data Sheet



Description

The control valves C 906 is a safety valve which closes when the flow speed exceeds a preset value. Protects against downstream pipe breakage. Re-set manually. Over speed protection : it closes and keeps closed in case of defect in the pipe work (breakage downstream). It will be re-set manually after repairing or cancellation of the defect on the main pipe work.



C 906

Over speed protection

DN mm	PN	PFA in bar	PS				Cat	Ref.	Weight* Kg
			L1	L2	G1	G2			
40	10/16/25	25	25	25	x	x	4.3	149B022653	15
50	10/16/25	25	25	25	x	x	4.3	149B015519	16
65	10/16/25	25	25	25	x	x	4.3	149B90606N	24
80	10/16/25	25	25	25	x	x	4.3	149B90608N	29
100	10/16	16	16	16	x	x	4.3	149B90610N	42
125	10/16	16	16	16	x	x	4.3	149B90611N	63
150	10/16	16	16	16	x	x	4.3	149B90612N	77
200	10	10	10	10	x	x	4.3	149B90614N	127
250	10	10	10	10	x	x	I	-	218
300	10	10	10	10	x	x	I	149B90616N	348

* Weight of valve alone

Important notice :

The indicated pressure for the different categories of fluids (L1/L2/G1/G2) is under no condition a guarantee of use. Therefore, it is essential to validate the use of products under given operating conditions.

Technical features	
Operating temperature	-10 °C to 90 °C
Upstream pressure	Mini. : 1,5 bar / Maxi. : 25 bar (see table above)
Connection	With flange PN (see table above)
Mediums	Clear water 2 mm
Viscosity	< to 40 cst
Vertical mounting	See option n°7

Nomenclature and materials

N°	Description	Materials	EURO	ANSI
1	Membrane	EPDM / Polyamide		
2	Position indicator with drain	Brass and stainless steel	EN 12164-CuZn39Pb3-R360min EN 10088-3-X5CrNi18-10 EPDM Cu	ASTM B36 / ASTM B121 AISI 304 / ASTM A240 UNS C10200
3	Valve head high pressure	Cast iron / Epoxy Int/Ext	EN 1563 EN-GJS-400-15 except DN 125 : EN 1561-EN-GJL-300	ASTM A536 60-40-18 ASTM A48 class 45B
4	Nuts and bolts	Stainless steel	EN 10088-3-X5CrNi18-10	AISI 304 / ASTM A240
5	Removable seat	Stainless steel	EN 10213-GX5CrNi19-10+AT	AISI 304 / ASTM A240
6	Body drain plug and valve	Brass	EN 12164-CuZn39Pb3-R360min	ASTM B36 / ASTM B121
7	Reversible seat seal	EPDM		
8	Body high pressure	Cast iron / Epoxy Int/Ext 200µ ± 40µ	EN 1563 EN-GJS-400-15 except DN 125 : EN 1561-EN-GJL-300	ASTM A536 60-40-18 ASTM A48 class 45B
9-10	Pressure connection drilling	Chromed brass		
11	Stem	Stainless steel	EN10213-GX5CrNi19-10-AT	AISI 304 / ASTM A240
12	Flange	Stainless steel	EN10088-3X5CrNi18-10	AISI 304 / ASTM A240
13	Seal carrier	Bronze (DN40-50) Ductile iron / Epoxy	EN1982 CuSn5Zn5Pb2-C GS EN1561-EN-GJL-250	ASTM A 48 35 B
14	Plate	Bronze (DN40-50) Ductile iron / Epoxy	EN1982 CuSn5Zn5Pb2-C GS EN1561-EN-GJL-250	ASTM A 48 35 B
15	Spring	Stainless steel	EN10270-3 X10CrNi18-8	AISI 302

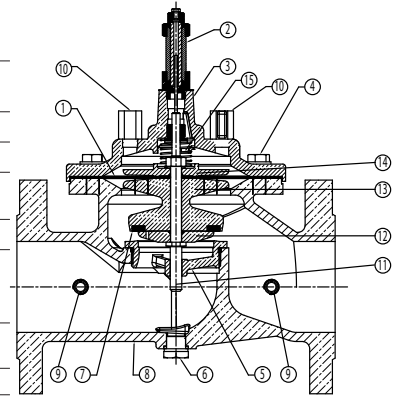

standard flow valve C 900

Approvals

ACS  PED 2014/68/UE **WRAS**

International construction Standards :

Directive 2014/68/UE

Connection with flange PN according to EN 1092-2

Application

The control valves C 906 is used when over flow protection is required (pressure pipeline, outlet of barrage) or to protect against failure in downstream pipe work (irrigation).

Operation

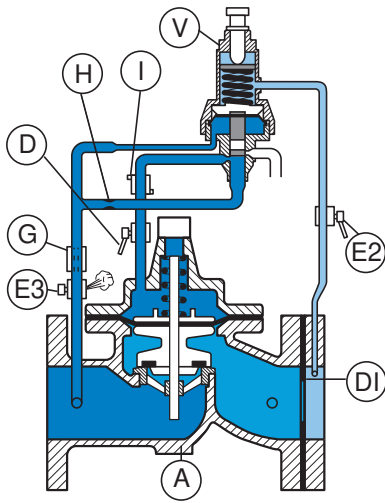

When the flow rate is smaller than the flow rate when cut off, the head loss at the diaphragm (D) + valve (A) is smaller than the pre-set value of the spring.

The drawer of pilot (V) allows the chamber to be put to the atmosphere.

Valve (A) opens.

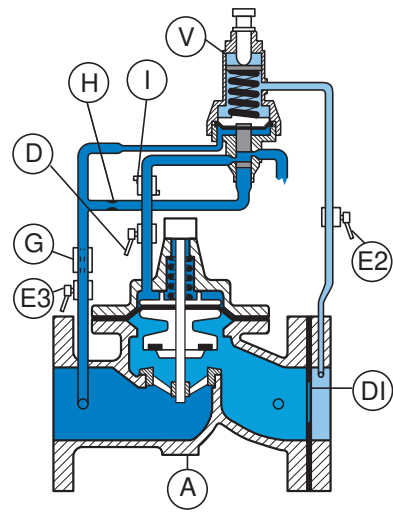

When the safety flow rate is reached, or by down-stream pipe breakage, the head loss at the diaphragm (D) + valve (A) becomes higher than the preset value of pilot (V).

The drawer of pilot allows to put the chamber under pressure.

The valve (A) will be locked. Action on (E3) to unlock.

Installation

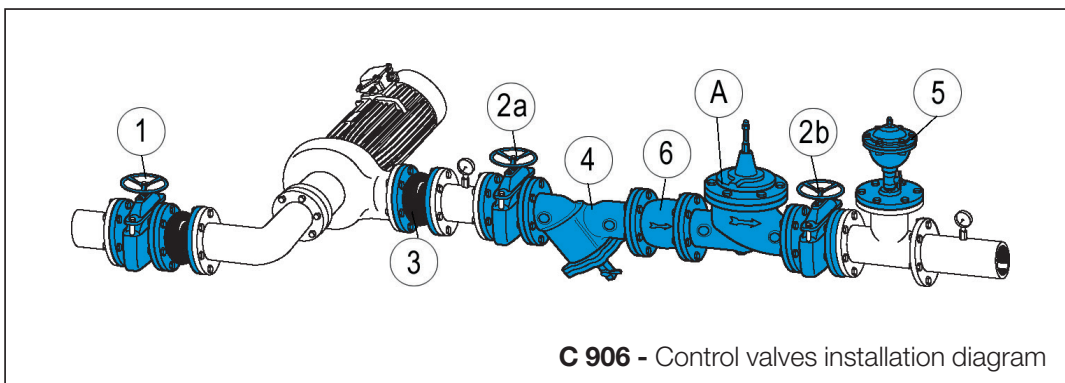

N°	Description
A	Main valve
E3	Unlocking valve
D	Chamber isolation valve
D1	Diaphragm
E2	Diaphragm isolation valve
G	Filter
H	Orifice-needle valve
I	Flow control
V	Pilot C906
1	Isolation valve of the pump
2a	Upstream isolation valve of the main pipe and of the pump
2b	Downstream isolation valve of the main water pipe
3	Rubber expansion joint
4	Filter
5	Single function air valve
6	Non return valve of the pump

Setting range :

- 0,2 to 0,5 bar
- 0,6 to 0,8 bar
- 0,9 to 6 bar

Installation :

- install a strainer upstream
- install an air relief valve downstream or at the high point near the control valve.
- horizontal setting up : the cap of the valve should be oriented to the top and inclined at 45° maximum
- vertical mounting : change the spring of the main valve (option 7)
- keep a downstream pressure

Other types :

- C916

Maintenance

We recommend a maintenance programme of between 6 to 12 months according to the quality of the water and to the pressure :

- Purging the upper chamber
- Flushing the valves not frequently used
- Checking and cleaning filters of the pilot circuit and main piping system.
- Checking the working (pressures)

Every 5 years, general maintenance is advisable :

- Dismantling
- Cleaning of main valve and pilot valve
- Preventive removing of the seals (set available - please consult us)
- Reassembling and tests.

Operating characteristics

Choice of base valve

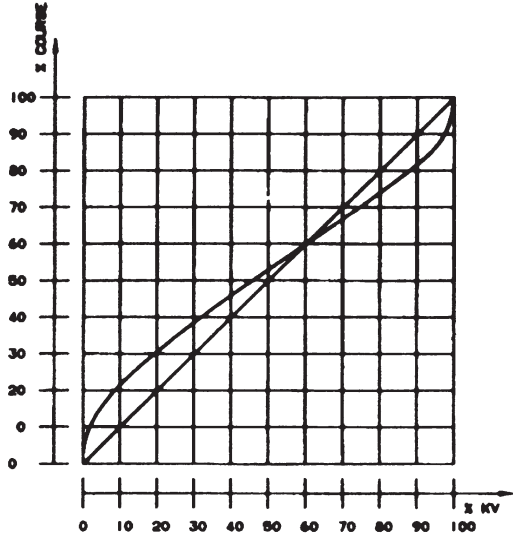

DN	Mini	Maxi	KV		ζ	PN	PFA	PN	PFA	PN	PFA
			m ³ /h	L/s		bar	bar	bar	bar	bar	bar
40	4,5	32,00	45,66	12,68	1,93	10/16	16	25	25	-	-
50	7	32,00	45,66	12,68	4,70	10/16	16	25	25	-	-
65	12	54,00	57,75	16,08	8,39	10/16	16	25	25	-	-
80	18	82,00	80,00	22,22	10,00	10/16	16	25	25	-	-
100	28	127,00	136,00	37,78	8,47	10/16	16	25	25	-	-
125	44	199,00	220,00	61,11	7,90	10/16	16	25	25	-	-
150	64	286,00	264,00	73,33	11,38	10/16	16	25	25	-	-
200	113	509,00	600,00	166,67	6,96	10	10	25	25	16	16
250	177	795,00	900,00	250,00	7,56	10	10	25	25	16	16
300	255	1145,00	1224,00	340,00	8,47	10	10	25	25	16	16

Sizing

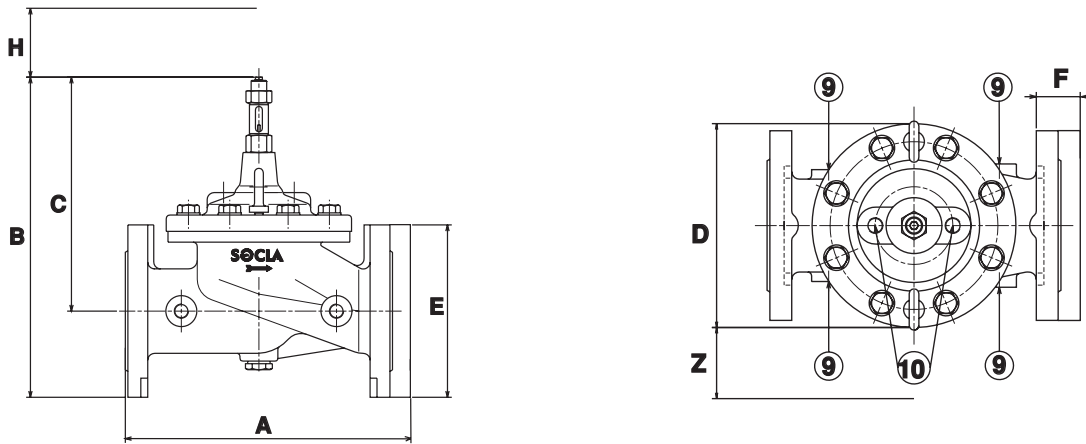

standard flow valve C 900

DN	A	B	C	D	E	F	G	H	Z	9	10
mm	mm	mm	mm	mm	mm	mm	mm	mm	mm	"	"
40	274	285	210	170	152	23	57	55	254	1/4	1/4
50	274	285	210	170	161	23	57	55	254	1/4	1/4
60	314	352	257	200	185	24	48	76	254	3/8	1/4
65	334	372	272	217	200	26	50	90	254	3/8	3/8
100	374	423	302	241	235	28	52	90	254	3/8	3/8
125	430	506	371	296	270	30	60	100	254	3/8	3/8
150	512	551	401	363	300	20	52	100	254	3/8	3/8
200	626	709	529	467	360	22	48	114	254	3/8	3/8
250	760	844	631	587	425	24	54	127	254	1/2	1/2
300	880	975	730	680	486	27	57	140	254	1/2	1/2

Other operating characteristics

Cavitation

A too large differential pressure and a low downstream pressure may result in damage to the valve by cavitation.

To avoid it, refer to the cavitation curve and if needed, reduce the differential pressure by installing and connecting two or more control valves in same line (consult us).

Stainless steel seat and counter seat are standard.

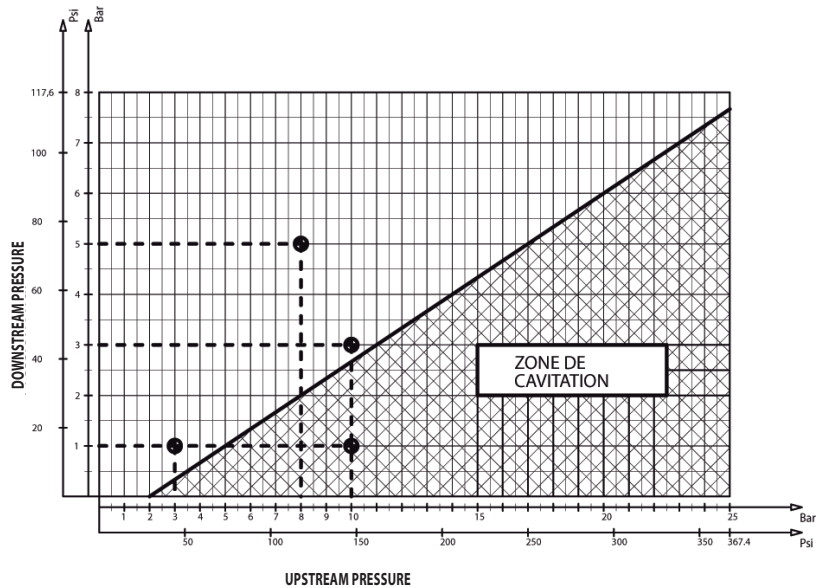

The descriptions and photographs contained in this product specification sheet are supplied by way of information only and are not binding.

Socla reserves the right to carry out any technical and design improvements to its products without prior notice. Warranty : All sales and contracts for sale are expressly conditioned on the buyer's assent to Socla terms and conditions found on its website at www.socla.com. Socla hereby objects to any term, different from or additional to Socla terms, contained in any buyer communication in any form, unless agreed to in a writing signed by an officer of Socla.



A WATTS Brand

Socla sas

365 rue du Lieutenant Putier • 71530 Virey-Le-Grand • France

Tel. +33 03 85 97 42 00 • Fax +33 03 85 97 42 42

contact@wattswater.com • www.socla.com

ISO 9001 version 2015 / ISO 18001