

**2 PIECES CARBON STEEL BALL VALVE FLANGED CLASS 150 PN20 JC RANGE
LONG PATTERN (ASME B16.10 TABLE 1-18) PTFE SEAT**

2 pieces split body ball valve JC with full bore for Chemical industries, petrochemical industries, hydraulic installation, heating, water distribution, compressed air.

Ball valve with firesafe certificate ISO 10497 and API 607 to reduce risks in case of fire.

Fugitive emission according to EN 15848-1 :2006 B Class and TA LUFT for an excellent tightness on the stem and to prevent external leakage.

PTFE seat for a temperature up to +230°C.

Compatible with explosive atmosphere, ATEX Zone 1&21 and Zone 2&22 thanks to the double antistatic device.

Handling possible with locking device, gearbox, oval handwheel or stem extension.

Thanks to the ISO 5211 plate, an actuator can be installed on the valve.



**JC
VALVES**



NACE MR01-75

Size : DN15 to DN300 (NPS 1/2" to 12")
Connection : Flanges Class 150 PN20 RF
Min Temperature : -29°C
Max Temperature : +230°C
Max Pressure : 20 Bars
Specifications : PTFE seat
 ISO 5211 mounting pad
 Anti blow-out stem, full bore
 Fire safe ISO 10497 : 2004, API 607 5th, BS
 6755 Part 2 and API 6FA

Materials : Carbon steel ASTM A216 WCB

*the installation defects and wear defects are not covered by the guarantee

**2 PIECES CARBON STEEL BALL VALVE FLANGED CLASS 150 PN20 JC RANGE
LONG PATTERN (ASME B16.10 TABLE 1-18) PTFE SEAT**

SPECIFICATIONS :

- Full bore
- Anti blow-out stem
- PTFE seat
- Locking device on request
- ISO 5211 mounting pad
- 2 pieces type (Split body)
- Class 150 PN20 Flanges R.F.
- Antistatic device
- Fire safe ISO 10497 : 2004, API 607 5th, BS 6755 Part.2 and API 6FA
- Fugitive emissions EN 15848-1 : 2006 and TA LUFT VDI 2440
- Graphite packing + FKM O ring on stem
- With exhaust hole in the ball (located in the top of the ball to avoid overpressure in it)
- Trunnion mounted hollow ball from DN250 (10") to DN300 (12")
- Painting color RAL 5009, 15-50 μ thickness

USE :

- Chemical industries, petrochemical industries, hydraulic installation, heating, water distribution, compressed air
- Min and max Temperature Ts : -29°C to + 230°C
- Max Pressure Ps : 20 bars (see graph)
- Vacuum 10⁻² torr
- Compressed air (ambient temperature) : 16 bars maximum
- Steam : 12 bars maximum

PRESSURE / TEMPERATURE GRAPH (STEAM EXCLUDED) :

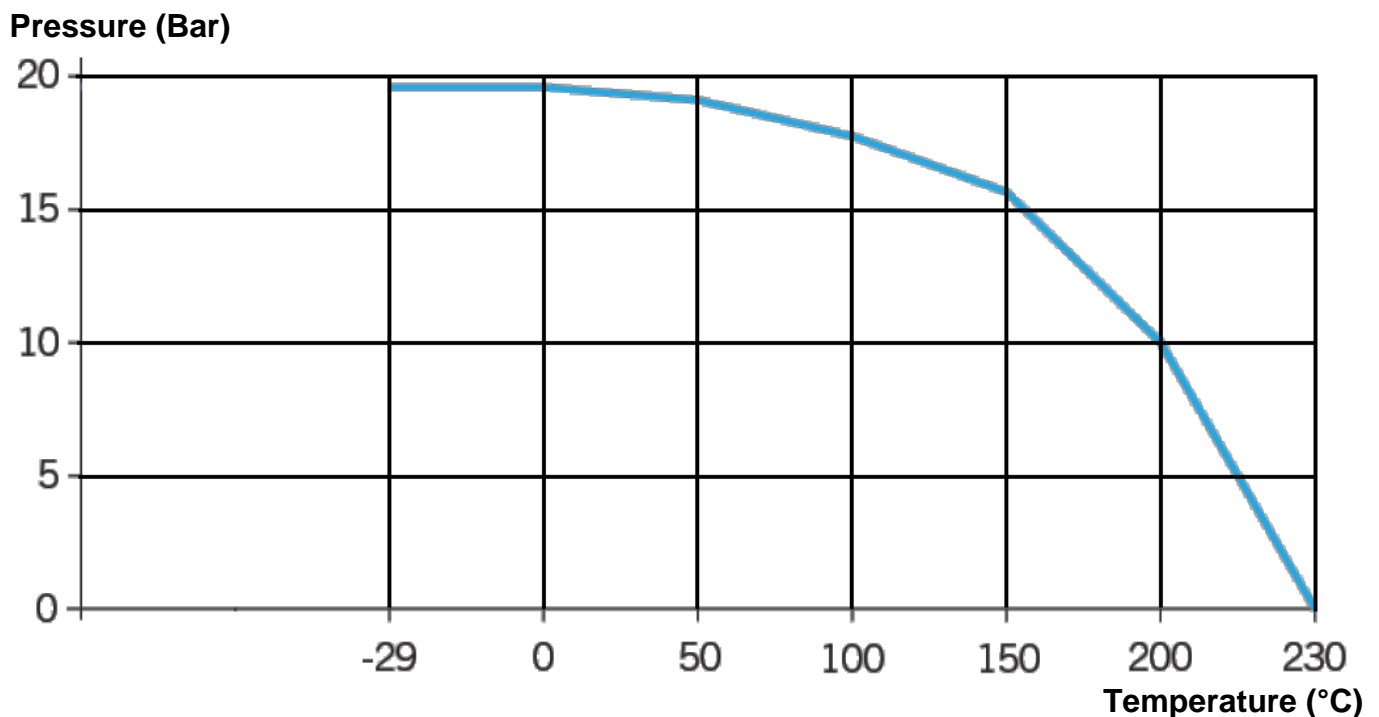

**2 PIECES CARBON STEEL BALL VALVE FLANGED CLASS 150 PN20 JC RANGE
LONG PATTERN (ASME B16.10 TABLE 1-18) PTFE SEAT**

FLOW COEFFICIENT Kvs (in m³ / h) :

NPS (")	1/2"	3/4"	1"	1"1/2"	2"	2"1/2"	3"	4"	6"	8"	10"
DN	15	20	25	40	50	80	100	150	200	250	300
Kvs (m ³ / h)	20	40	75	170	270	1000	1650	4200	9000	15000	20800

TORQUE VALUE (in Nm without safety coefficient) at 20 bars :

NPS (")	DN	BTO	RTO	ETO	BTC	RTC	ETC	MAST
1/2"	15	9	5	5	7	5	7	26
3/4"	20	13	7	8	10	7	10	26
1"	25	17	9	10	13	9	14	26
1"1/2"	40	30	15	18	23	15	24	85
2"	50	43	22	26	32	22	34	85
2"1/2"	65	66	33	40	50	33	53	176
3"	80	95	48	57	71	48	76	246
4"	100	150	75	90	113	75	120	305
6"	150	326	163	196	245	163	261	974
8"	200	729	365	437	547	365	583	1387
10"	250	1280	640	768	960	640	1024	1387
12"	300	1500	750	900	1125	750	1200	2541

RANGE :

- Carbon steel body ball valve with handle flanged Class 150 PN20 **Ref. 515AIT** from DN 15 to DN 150 (NPS 1/2" to 6")
- Carbon steel body ball valve with free stem Class 150 PN20 **Ref. 515AIT** DN200 (NPS 8")
- Carbon steel body ball valve with free stem Class 150 PN20 **Ref. 1515AIT** from DN250 to 300 (NPS 10" to 12")

CONNECTION :

- Class 150 PN20 R.F. Flanges

**2 PIECES CARBON STEEL BALL VALVE FLANGED CLASS 150 PN20 JC RANGE
LONG PATTERN (ASME B16.10 TABLE 1-18) PTFE SEAT**

ACCESSORIES :



- Reinforced locking device

DN (mm)	15	20	25	32	40	50	65	80	100	125	150	200
NPS (")	1/2"	3/4"	1"	1"1/4	1"1/2	2"	2"1/2	3"	4"	5"	6"	8"
Ref.	9830120		9830121	9830122	9830123		9830124	9830125	9830126	9830127	9830128	9830129

- Stainless steel handle



DN (mm)	15	20	25	32	40	50	65	80	100	125	150
NPS (")	1/2"	3/4"	1"	1"1/4	1"1/2	2"	2"1/2	3"	4"	5"	6"
Ref.	9830513			9830514	9830515		9830516	9830517	9830518	9830519	9830520

- Stainless steel oval handwheel



DN (mm)	15	20	25	32	40	50
NPS (")	1/2"	3/4"	1"	1"1/4	1"1/2	2"
Ref.	9830575	9830578		9830576	9830577	

- Gearbox



DN (mm)	125	150	200
NPS (")	5"	6"	8"
Ref.316	9830598	9830592	9830593
Ref.340			983595

- Single Stainless steel stem extension 100 mm



DN (mm)	15	20	25	32	40	50	65	80	100	125	150
NPS (")	1/2"	3/4"	1"	1"1/4	1"1/2	2"	2"1/2	3"	4"	5"	6"
Ref. JC	9810615		9810616	9810617		9810618	9810619	9810620	9810621	9810622	

- Stainless steel stem extension 100 mm with ISO plate



DN (mm)	15	20	25	32	40	50	65	80	100	125	150	200
NPS (")	1/2"	3/4"	1"	1"1/4	1"1/2	2"	2"1/2	3"	4"	5"	6"	8"
Ref. SF	JCRISO015020	JCRISO025	JCRISO032	JCRISO040050		JCRISO065	JCRISO080	JCRISO100	JCVSSBI125	JCVSSBI150	JCVSSBI200	

**2 PIECES CARBON STEEL BALL VALVE FLANGED CLASS 150 PN20 JC RANGE
LONG PATTERN (ASME B16.10 TABLE 1-18) PTFE SEAT**

VALVE MATERIALS DN15-200 (NPS 1/2" to 8") :

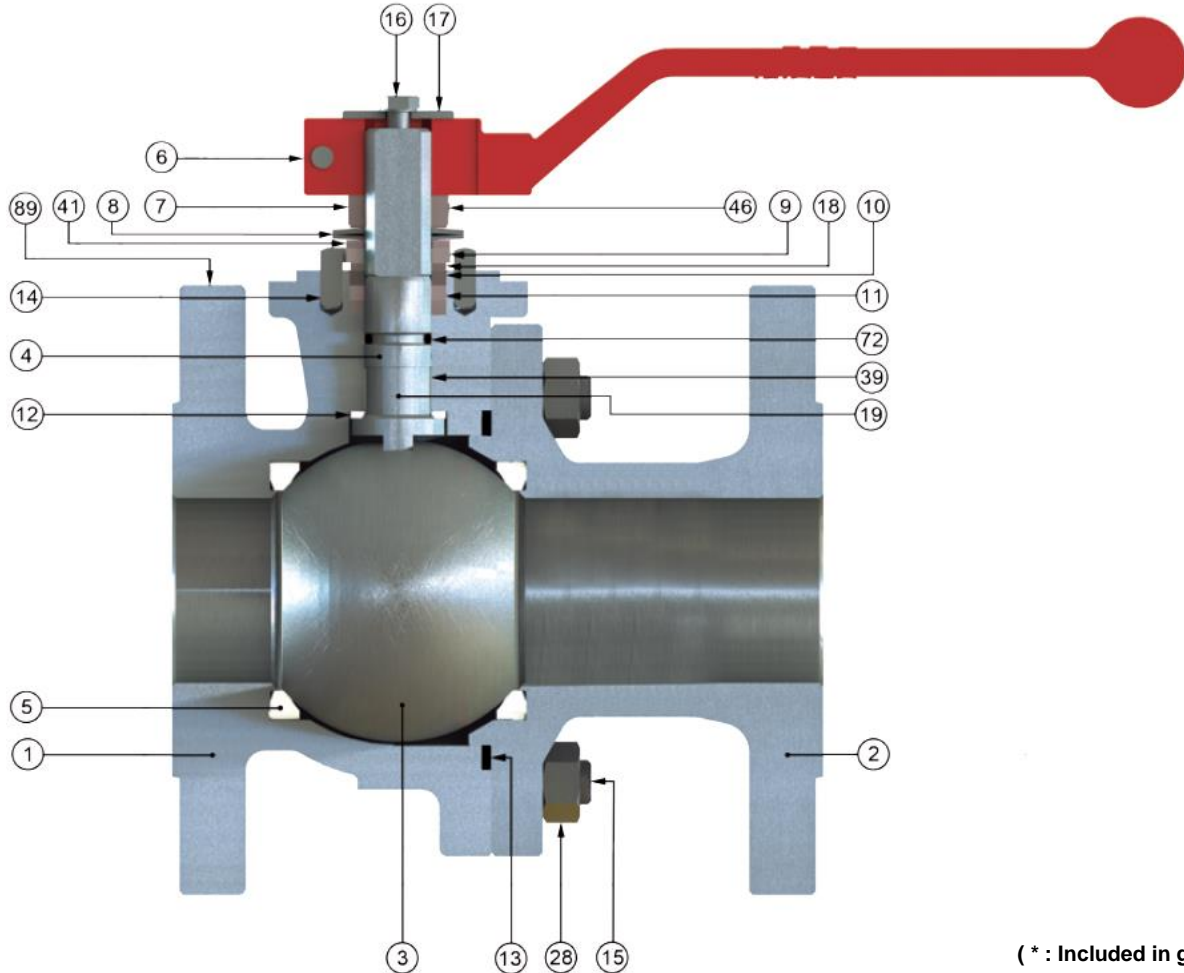

(* : Included in gaskets kit)

Item	Designation	Materials
1	Body	ASTM A216 WCB
2	Ends	
3	Ball DN15-25	ASTM A479 Tp.316
	Ball DN 32-200	Inox ASTM A 351 CF8M
4	Stem	ASTM A479 Tp.316
5*	Seat	PTFE
6	Handle	Ductile iron
7	Packing nut	Carbon Steel
8	Elastic ring	Carbon Steel
9	Stop washer	Carbon Steel
10	Packing gland	AISI 303
11*	Packing	Graphite
12*	Gasket	PTFE filled with 25% glass

Item	Designation	Materials
13*	Body spiral seat	AISI 316L + PTFE + Graphite
14	Pin	Carbon Steel
15	Screw (stud DN32-100)	A193 Gr. B7M zinc dichr .
16	Handle screw	DIN 933 A2-70
17	Washer	Zinc plated carbon steel
18*	Thrust washer	PTFE filled with 25% glass
19	Antistatic device	Stainless steel
28	Nut (DN32-100)	A 194 Gr. 2HM zinc dichr .
39	Stem bushing (DN25-200)	PTFE filled with 25% glass
41	Spacer (DN40-200)	Carbon Steel
46*	Washer	AISI 304
72*	O ring	FKM
89	ID plate	Stainless steel

**2 PIECES CARBON STEEL BALL VALVE FLANGED CLASS 150 PN20 JC RANGE
LONG PATTERN (ASME B16.10 TABLE 1-18) PTFE SEAT**

VALVE MATERIALS DN 250-300 (NPS 10" to 12") :

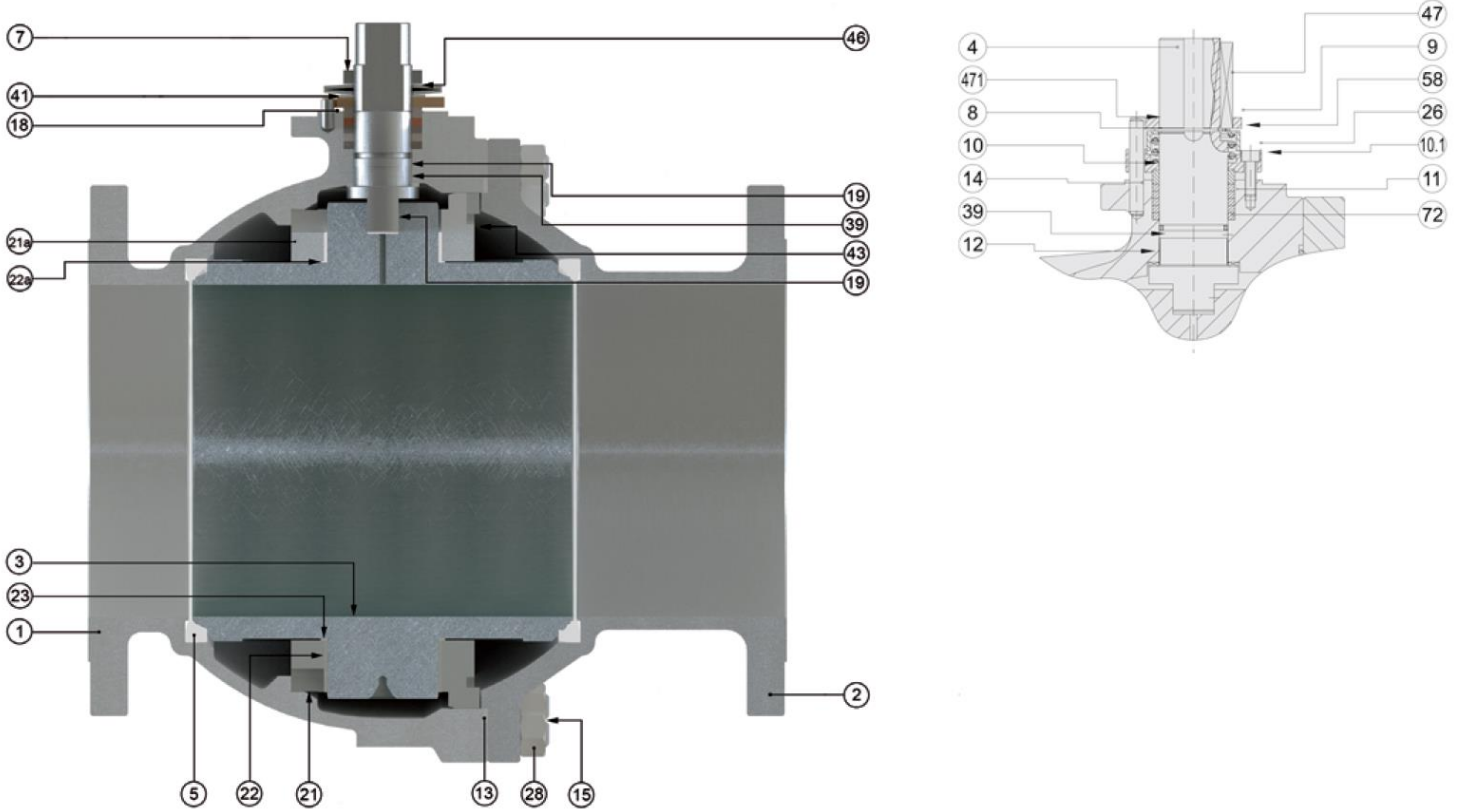

(* : Included in gaskets kit)

Item	Designation	Materials
1	Body	ASTM A216 WCB
2	Ends	
3	Ball	ASTM A 351 CF8M
4	Stem	ASTM A479 Tp.316
5*	Seat	PTFE
7	Packing gland	Ductile iron
8	Elastic washer	Zinc plated carbon steel
9	Pin	Carbon steel
10	Gland	
10.1	Ring	AISI 303
11*	Packing	PTFE
12*	Gasket	PTFE filled with 25% glass
13*	Body seat	AISI 316L + PTFE+ Graphite
14	Stop pin	Carbon steel
15	Stud	A193 Gr. B7M

Item	Designation	Materials
18*	Bushing	PTFE filled with 25% glass
19	Antistatic device	Stainless steel
21/21a	Ball trunnion	AISI 316
22/22a	Trunnion bearing	PTFE + 50% Stainless steel
23	Bearing	PTFE
26	Bolt	DIN 912 8.8 zinc plated
28	Nut (only for DN250)	A 194 Gr. 2HM
39	Stem bushing	PTFE + 50% Stainless steel
41	Spacer	Carbon steel
43-47	Key	AISI 316
46*	Locking washer	AISI 304
58	Spring protection	Carbon steel
72*	O ring	FKM
89	ID plate	Stainless steel
471	Retainer	DIN 933 A2-70

**2 PIECES CARBON STEEL BALL VALVE FLANGED CLASS 150 PN20 JC RANGE
LONG PATTERN (ASME B16.10 TABLE 1-18) PTFE SEAT**

GEARBOX MATERIALS :

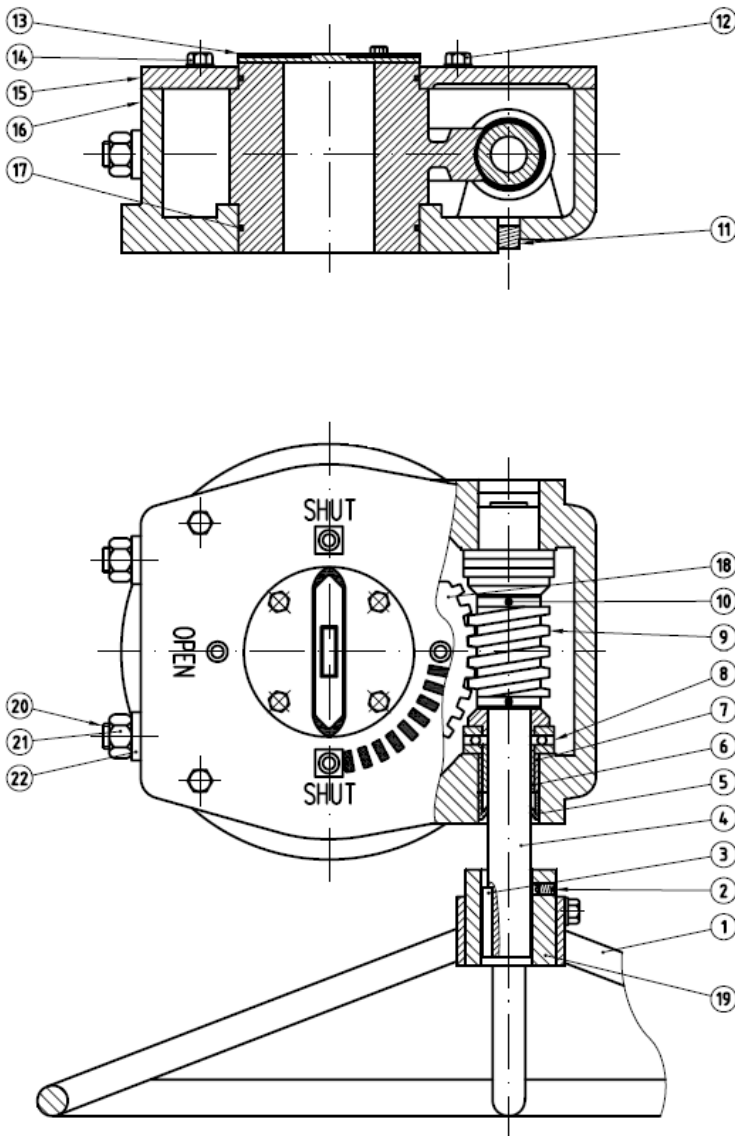

Item	Designation	Materials
1	Handwheel	Carbon steel
2	Screw	
3	Stem key	
4	Input shaft	AISI 1045
5	Oil seal	Rubber
6	Bearing	Cu Base Alloy
7	Oil bearing	
8	Thrust bearing	Carbon steel
9	Worm	AISI 1045
10	Pin	Carbon steel
11	Plug	
12	Screw	
13	Indicator plate	Cast iron
14	Screw	Carbon steel
15	Cover	Cast iron
16	Housing	
17	O ring	Rubber
18	Worm gear	Ductile iron
19	Nut	Carbon steel
20	Stop screw	
21	Nut	
22	Hex nut	
23-24	Spur gear cover+housing	Cast iron
25	Seal cover	Rubber
26-27-28	Screw+washer	Carbon steel
29	Gear	
30	Bearing	Cu Base Alloy
31	Bolt	Carbon steel
32	Slotted spring pin	
33	Spur gear	
34	Locator pins	

**2 PIECES CARBON STEEL BALL VALVE FLANGED CLASS 150 PN20 JC RANGE
LONG PATTERN (ASME B16.10 TABLE 1-18) PTFE SEAT**

VALVE SIZE DN15-200 (NPS 1/2" to 8") (in mm) :

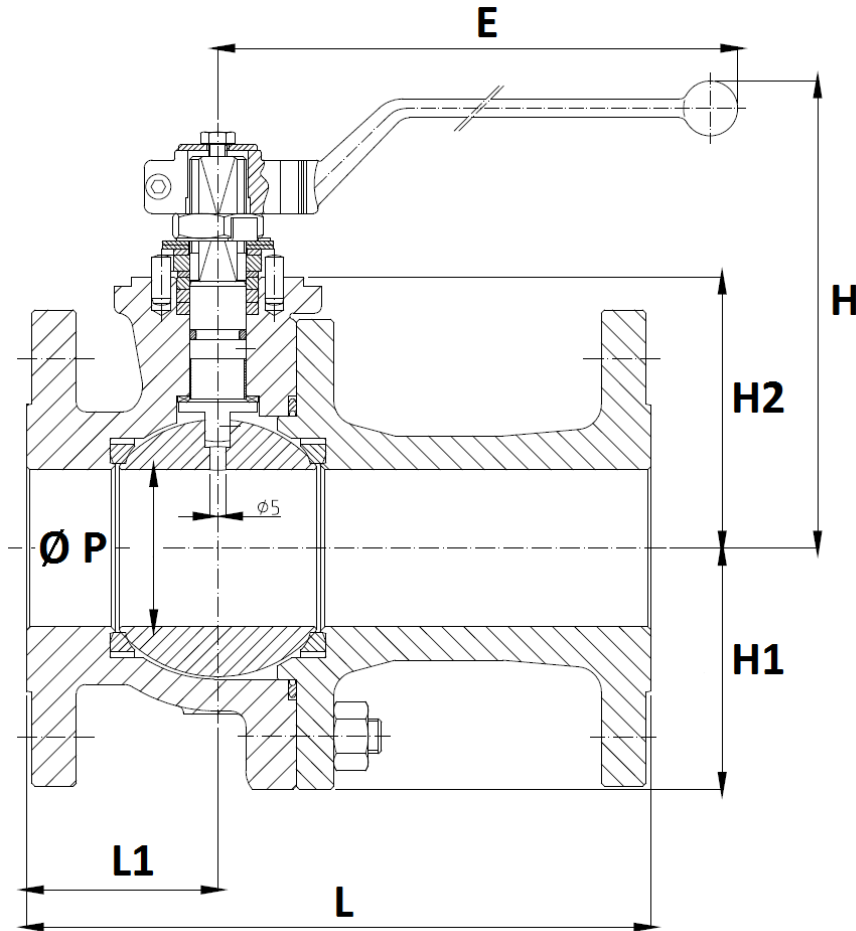

NPS (")	1/2"	3/4"	1"	1"1/2"	2"	2"1/2"	3"	4"	6"	8"*
DN	15	20	25	40	50	65	80	100	150	200*
Ø P	15	20	25	40	50	65	80	100	151	203
L	108	117	127	165	178	190	203	229	394	457
L1	47	50	52	65	61	75	78.5	90	174	200
E	164	164	164	213	213	348	445	495	698	868
H	111	118	130	148	155	169	207	232	299	353
H1	-	-	-	-	-	-	-	120	168	208
H2	46	53	58	76	83.5	97	111	133	183	233
Weig. (Kg)	2	3	3.5	8	11	16	23	38	88	155
Ref.	515AIT015	515AIT020	515AIT025	515AIT040	515AIT050	515AIT065	515AIT080	515AIT100	515AIT150	515AIT200

* Handle on request for DN200 (free stem in standard)

**2 PIECES CARBON STEEL BALL VALVE FLANGED CLASS 150 PN20 JC RANGE
LONG PATTERN (ASME B16.10 TABLE 1-18) PTFE SEAT**

VALVE SIZE DN 250-300 (NPS 10" to 12") (in mm) :

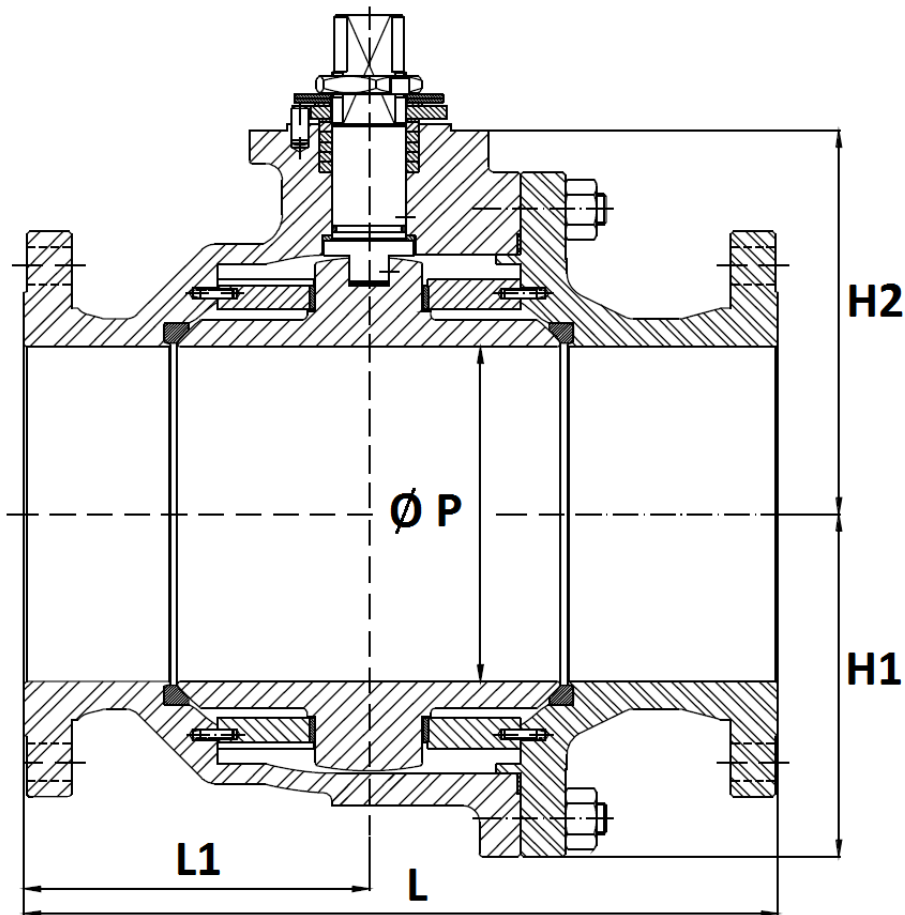

NPS (")	10"	12"
DN	250	300
Ø P	254	305
L	533	610
L1	225	245
H1	239	288
H2	256	297
Weight (in Kg)	237	357
Ref.	515AIT250	515AIT300

**2 PIECES CARBON STEEL BALL VALVE FLANGED CLASS 150 PN20 JC RANGE
LONG PATTERN (ASME B16.10 TABLE 1-18) PTFE SEAT**

ISO MOUNTING PAD AND STEM SIZE DN15-200, (NPS 1/2" to 8") (in mm) :

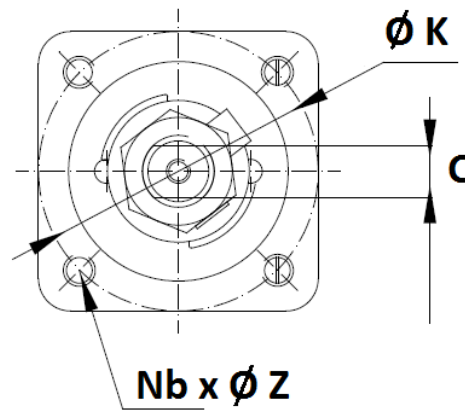
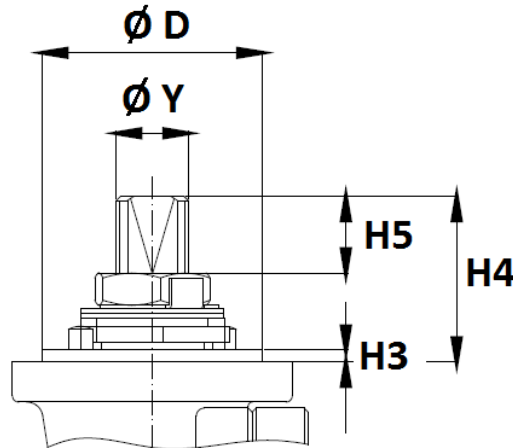

NPS (")	1/2"	3/4"	1"	1 1/2"	2"	2 1/2"	3"	4"	6"	8"
DN	15	20	25	40	50	65	80	100	150	200
H3	1.5			3						4
H4	11.2	14.7	22.7	41.5	41.5	44	44.5	56.5	68	72
H5	5	8.5	9.5	18.3	18.3	18.6	18.6	27.8	37.1	36.5
C	9	9	9	13	13	16	18	20	29	32
Ø Y	M12x1.5			M18x1.5		M22x1.5	M25x1.5	M28x1.5	M40x2	M45x2
Ø D	35			55			70		85	100
Ø K	50			70			102		125	140
ISO	F05			F07			F10		F12	F14
N x Ø Z	4 x M6			4 x M8			4 x M10		4 x M12	4 x M16

**2 PIECES CARBON STEEL BALL VALVE FLANGED CLASS 150 PN20 JC RANGE
LONG PATTERN (ASME B16.10 TABLE 1-18) PTFE SEAT**

ISO MOUNTING PAD AND STEM SIZE DN250-300 (NPS 10" to 12") (in mm) :

DN 250 (10")

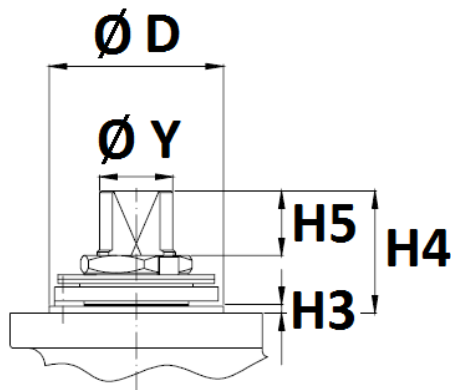

DN300 (12")

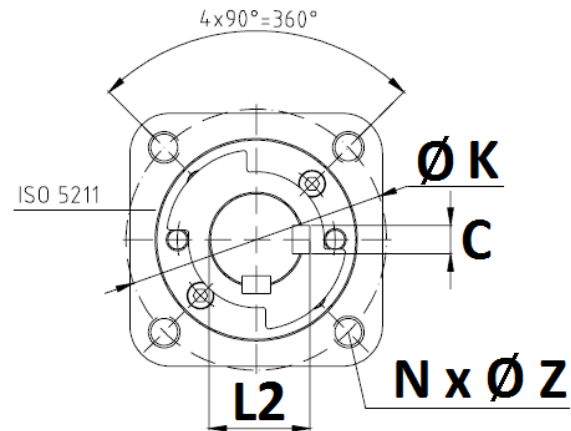
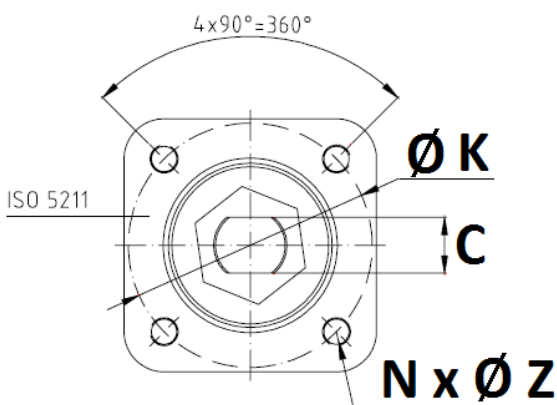
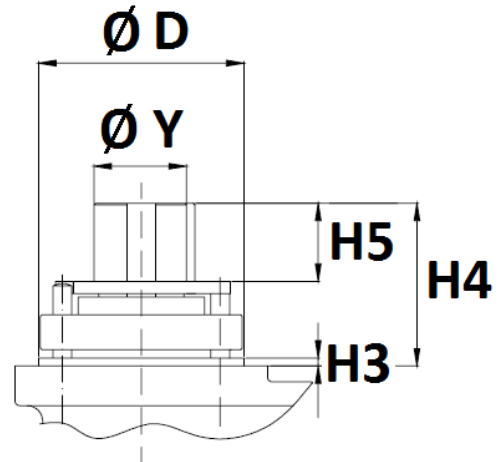

NPS (")	10"	12"
DN	250	300
H3	4	3
H4	72	106
H5	36.5	58
L2	-	53.5
C	32	14
Ø Y	M45x2	Ø50
Ø D	100	100
Ø K	140	140
ISO	F14	F14
N x Ø Z	4 x M16	4 x M16

**2 PIECES CARBON STEEL BALL VALVE FLANGED CLASS 150 PN20 JC RANGE
LONG PATTERN (ASME B16.10 TABLE 1-18) PTFE SEAT**

GEARBOX SIZE DN125-300 NPS 5" to 12" (in mm) :

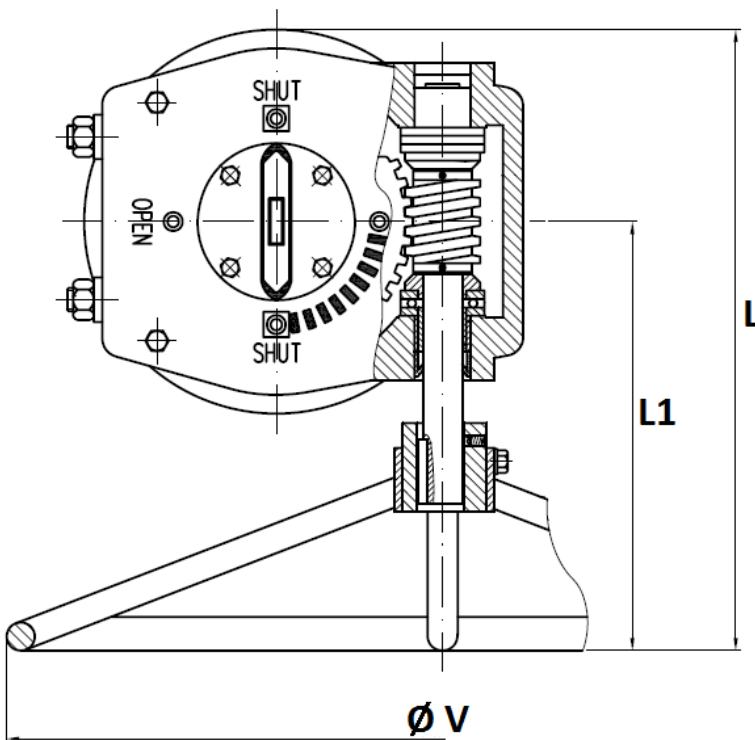
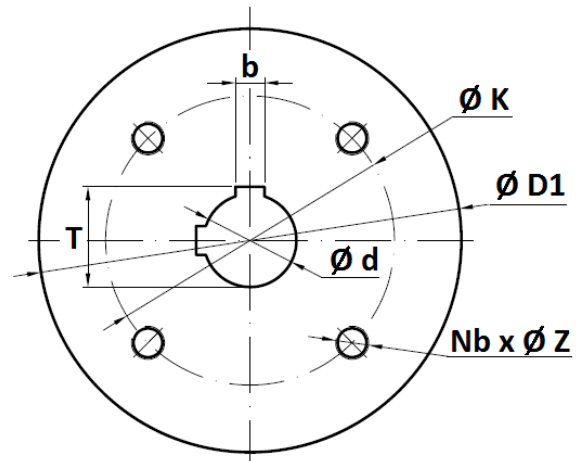
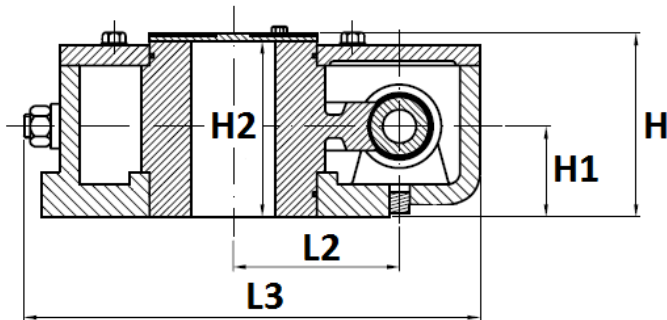

NPS (")	5"-6"-8"	10"	12"
DN	125-150-200	250	300
Ø V	465	600	600
L	331.5	487	544
L1	229	370	402
L2	77.5	90	126
L3	245	282	312
H	107	107	113.5
H1	55	55	65
H2	85	85	90
Ø d	45	65	80
Ø D1	205	254	290
Ø K	140	140	165
ISO	F14	F14	F16
Nb - Ø Z	4-M16x20	4-M16x20	4-M20x25
b	14	18	22
T	48.6	69.3	85.6
Weight (Kg)	17.8	22.5	36
Torque (Nm)	1200	2000	3300

**2 PIECES CARBON STEEL BALL VALVE FLANGED CLASS 150 PN20 JC RANGE
LONG PATTERN (ASME B16.10 TABLE 1-18) PTFE SEAT**

OVAL HANDWHEEL SIZE DN15-50 NPS 1/2" to 2" (in mm) :

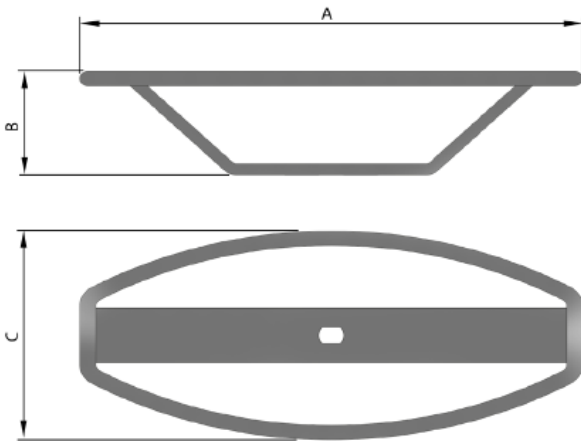

NPS (")	1/2"	3/4"	1"	1"1/2	2"
DN	15	20	25	40	50
A	160	160	160	216	216
B	54	54	54	57	57
C	75	75	75	100	100
Weight (Kg)	0.25	0.25	0.25	0.55	0.55
Ref.	9830575	9830578		9830577	

STAINLESS STEEL HANDLE SIZE DN15-200 NPS 1/2" to 8" (in mm) :

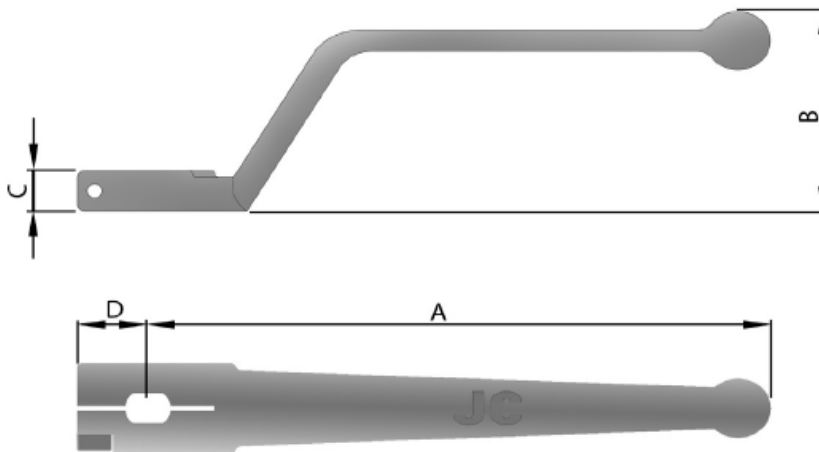

NPS (")	1/2"	3/4"	1"	1"1/2	2"	2"1/2	3"	4"	6"	8"
DN	15	20	25	40	50	65	80	100	150	200
A	163.5		212.5		347.5	445	495	697.5	867.5	
B	58.5		48.5		46.5	70	70	84.5	84.5	
C	12		21		20		29	40		
D	18.5		25.5			33		47	55	
Weight (Kg)	0.2		0.53		0.63	1.52	1.85	3.4	4.6	
Ref.	9830513		9830515		9830516	9830517	9830518	9830520		

**2 PIECES CARBON STEEL BALL VALVE FLANGED CLASS 150 PN20 JC RANGE
LONG PATTERN (ASME B16.10 TABLE 1-18) PTFE SEAT**

FLANGES SIZE (in mm) :

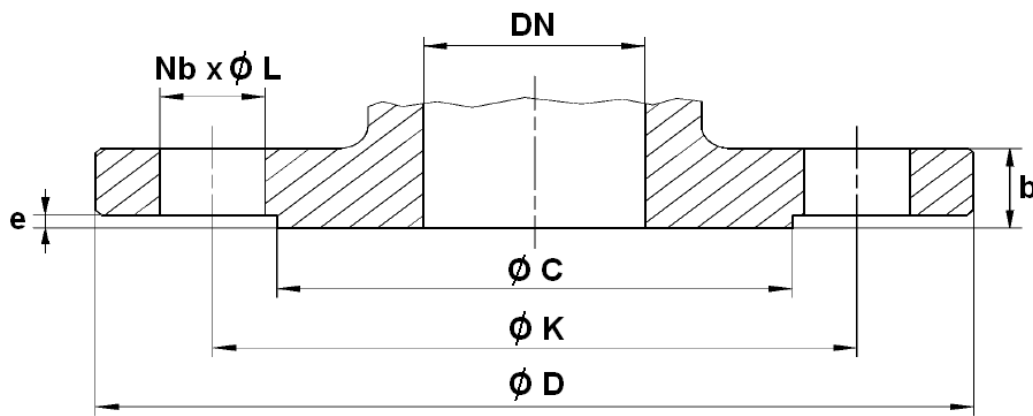

NPS (")	1/2"	3/4"	1"	1 1/2"	2"	2 1/2"	3"	4"	6"	8"	10"	12"
DN	15	20	25	40	50	65	80	100	150	200	250	300
Ø C	34.9	42.9	50.8	73	92.1	104.8	127	157.2	215.9	269.9	323.8	381
Ø D	90	100	110	125	150	180	190	230	280	345	405	485
Ø K	60.3	69.9	79.4	98.4	120.7	139.7	152.4	190.5	241.3	298.5	362	431.8
Nb x Ø L	4 x 15.9				4 x 19.1			8 x 19.1	8 x 22.2		12 x 25.4	
b	11.2	11.2	11.2	14.3	15.8	17.6	19	24.6	25.5	28.5	30.2	31.8
e	1.6											

**2 PIECES CARBON STEEL BALL VALVE FLANGED CLASS 150 PN20 JC RANGE
LONG PATTERN (ASME B16.10 TABLE 1-18) PTFE SEAT****STANDARDS :**

- Manufacturer certified ISO 9001:2015 and ISO 14001 : 2015
- DIRECTIVE 2014/68/EU : CE N° 0056
Risk Category IV module H1
- Certificate 3.1 on request
- Valve designing according to EN 1983 – ISO 17292, API 6D and ASME B16.34
- Body design according to ASME VIII Div.1
- Materials according to NACE MR 01-75
- Pressure Tests according to API 598
- Marking according to EN 19
- Fire safe according to ISO 10497 : 2004, API 607 5th, BS6755 Part 2, and API 6FA 1994
- Fugitive Emissions according to EN 15848-1 : 2006 B Class and TA LUFT VDI 2440
- SIL2 according to IEC/EN 61508, SIL 3 possible according to the type of installation
- Flanges R.F. type B1 Class 150 according to ASME B16.5
- Shell finishing quality MSS SP 55
- ISO 5211 mounting pad
- Length according to ASME B16.10 Table 1 Column 18 (EN 558 series 3 up to DN100, series 12 from DN150 to 300)
- ATEX Group II Category 2 G/2Dc Zone 1 & 21 Zone 2 & 22 (optional marking) according to directive 2014/34/EU
- Russian certificate TRCU 10, TRCU 12 and TRCU 32 (EAC marking and declaration **on request**)

ADVICE : Our opinion and our advice are not guaranteed and SFERACO shall not be liable for the consequences of damages.
The customer must check the right choice of the products with the real service conditions.