

422

Non-return axial guided valve
02 System

Technical Data Sheet



A non-return valve is compatible with many types of fluids and can be adapted to a wide range of installations. However, each of these installations comes with their own particular constraints : mechanical, hydraulic, physical or chemical. The O2 system offers the best compromise between hydraulic performance, ruggedness, sealing-tightness and cost effectiveness with any kind of liquids (subject to a validation of our recommendation service).

Our valves meet the requirements of the Pressure Equipment Directive 2014/68/UE. This range extends from 50 to 400 mm. By its technology, it operates in any position for a lot of applications. It's compact and it doesn't generate hammering.



422

Non-return axial guided valve - O2 System

DN in mm	PN	PFA in bar	PS in bar				Cat.	Ref.	Weight Kg
			L1	L2	G1	G2			
50	10/16	16	16	16	16	16	I	149B2679	5,8
65	10/16	16	16	16	15	16	I	149B2680	8,1
80	10/16	16	16	16	12	16	I	149B2681	10,2
100	10/16	16	16	16	10	16	I	149B2682	14,5
125	10/16	16	16	16	0,5	16	I	149B2683	24
150	10/16	16	13	16	0,5	16	I	149B2684	32
200	10	10	10	10	0,5	10	I	149B2685	53
250	10	10	10	10	0,5	10	I	149B2686	94
300	10	10	10	10	0,5	10	I	149B2687	140
350	10	10	10	10	0,5	10	I	149B2688	225
400	10	10	10	10	0,5	8	I	149B2689	312

Important notice :

The indicated pressure for the different categories of fluids (L1/L2/G1/G2) is under no condition a guarantee of use. Therefore, it is essential to validate the use of products under given operating conditions. The operating instructions are available on our web site www.socla.com or by requesting from our sales department.

Technical features

Operating temperature	-10 °C to 100 °C
Permissible operating pressure (PFA) in water	See table above
Maximum permissible pressure (PS) other mediums	See table above
Connection	Flanges drilled PN (see table)
Mediums	Not loaded liquids, gas

Nomenclature and materials

N°	Description	Materials	EURO	ANSI
1	Body	Cast iron / Epoxy	EN 1561 EN-GJL-250	ASTM A 48 35 B
2	Ring	Bronze	EN 1982 CuSn5Zn5Pb2-C GS	
3	Guide	Cast iron / Epoxy	EN 1561 EN-GJL-250	ASTM A 48 35 B
4	Spring	Stainless steel	EN 10270-3 X10CrNi18-8	AISI 302
5	Seal	EPDM		
6	Plug	Bronze	EN 1982 CuSn5Zn5Pb2-C GS	
7	Seat	Bronze	EN 1982 CuSn5Zn5Pb2-C GS	

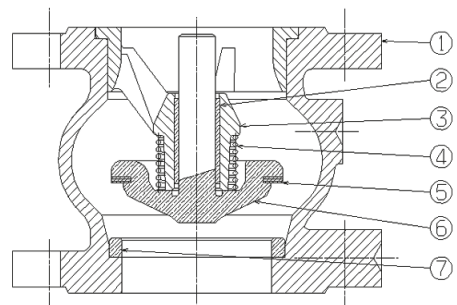

Approvals

ACS CE PED 2014/68/UE



International construction Standards :

Directive 2014/68/UE

Flange drilling according to EN1092-2

Application

Corrosion-resistant, pumping, supply, industry.

Installation

Installation :

Before putting valve into operation, check that :

- the working conditions are compatible with the details given on the identification plate, the instruction notice and the manufacturer's detail,
- the valve works effectively when tried (carry out a few opening and closing operations of the closing system),
- the valve is free-pollution inside.

On a new installation or after maintenance, the circuit must be rinsed with the valve completely open in order to remove solid matter which may damage the internal parts of the valve.

Commissioning :

The installation should be put under pressure progressively to avoid damage which might occur to internal components.

Make sure that when flow stops the valve maintains pressure well and that there is no water-hammer which might damage the valve or installation.

If there is water-hammer, an anti-water hammer system must be added to the installation.

During a prolonged stoppage, a change in the state of the fluid may result in damage when the installation is brought back into service (solidification...).

Establish an adequate procedure program for cleaning the system.

Maintenance

• Removing :

1. Remove the guide assembly (N°2)
2. Remove the o-ring seal (N°5) from its groove
3. Remove the spring (N°4)
4. Remove all the closing system (N°3)

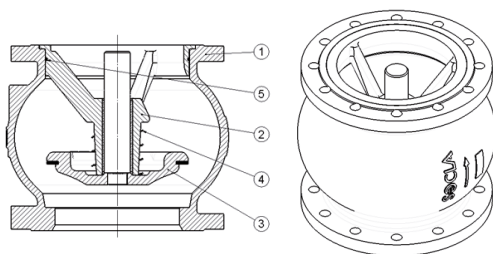

• Reassembly :

Make sure that the seal is in a good condition before reassembly the valve.

Clean and lubricate it if necessary with a suitable product.

1. Put all the closing system (N°3) into the casing (N°1)
2. Insert the spring (N°4)
3. Put the o-ring seal (N°5) in its groove
4. Insert the guide assembly (N°2). This step may require to use a press.

Once the reassembly done, test the device in order to check its sealing.

Operation

Direction for use :

- Solid line : Valve completely open
- Dotted line : opening stage of valve

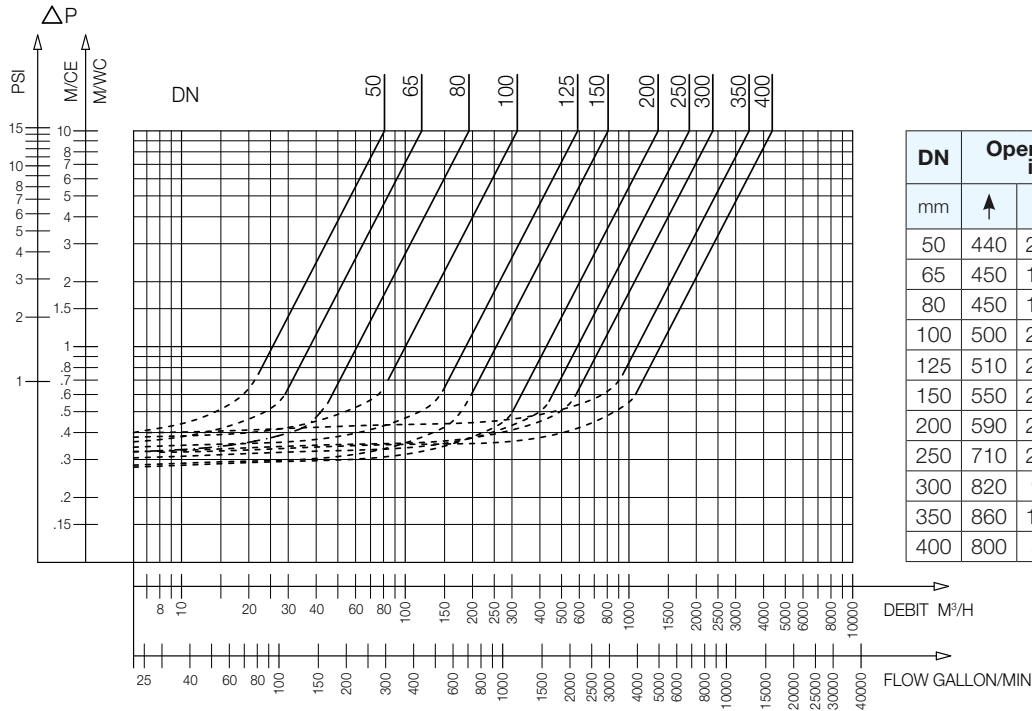

DN	Opening pressure in mm CE				Kv	ζ
	↑	↓	↔	Without spring		
50	440	220	230	110	80,8	1,50
65	450	190	320	130	118,5	2,00
80	450	190	320	130	192,8	1,80
100	500	240	370	130	318,0	1,60
125	510	210	360	150	590,0	1,10
150	550	210	380	170	807,5	1,25
200	590	210	400	190	1351,0	1,40
250	710	210	460	250	1861,8	1,80
300	820	90	460	365	2371,7	2,30
350	860	100	480	380	3444,7	2,00
400	800	50	410	390	4371,2	2,14

422 - Headloss chart

Sizing

A	B	C	D
mm	mm	mm	mm
50	165	97	100
65	185	125	120
80	200	150	140
100	220	187	170
125	250	220	200
150	285	250	230
200	340	340	289
250	405	420	354
300	460	490	395
350	533	586	473
400	597	680	560

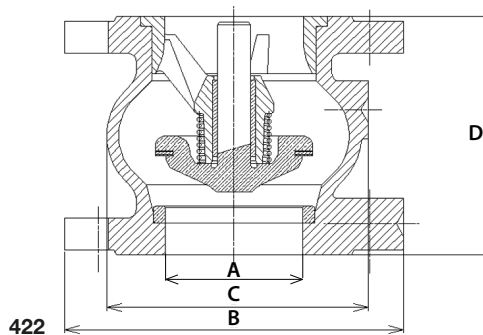

The descriptions and photographs contained in this product specification sheet are supplied by way of information only and are not binding.

Socla reserves the right to carry out any technical and design improvements to its products without prior notice. Warranty : All sales and contracts for sale are expressly conditioned on the buyer's assent to Socla terms and conditions found on its website at www.socla.com. Socla hereby objects to any term, different from or additional to Socla terms, contained in any buyer communication in any form, unless agreed to in a writing signed by an officer of Socla.



A WATTS Brand

Socla sas

365 rue du Lieutenant Putier • 71530 Virey-Le-Grand • France
 Tel. +33 03 85 97 42 00 • Fax +33 03 85 97 42 42
 contact@wattswater.com • www.socla.com
 ISO 9001 version 2015 / ISO 18001