

405

Non-return valve with single plate
05 System

Technical Data Sheet



Description

- The head loss is very low as the plate folds away completely
- The seat is vertical from DN 40 to DN 50 and inclined (relative to the axis of the pipe) from DN 65 to DN 300, making it easier to close.
- All parts in metal are coated, so there is no risk of corrosion.
- Its construction makes it easy to disassembly
- The check valve is designed with a drain plug from DN 65 to 300, plate may be lifted by external screw if required
- The valve can be fitted with a drain plug on demand for DN40 and DN 50
- The boss can also be used to mount a lifting system of the plate for degassing



405

Non-return valves with single plate - 05 System

DN mm	PN	PFA in bar	PS in bar				Cat.	Ref.	Weight Kg
			L1	L2	G1	G2			
40	10/16	16	16	16	0,5	16	4.3	149B3459	6
50	10/16	16	16	16	0,5	16	4.3	149B3460	7,5
65*	10/16	16	16	16	15	16	I	149B3461	13
80	10/16	16	16	16	12	16	I	149B3462	16
100	10/16	16	16	16	10	16	I	149B3463	26
125	10/16	16	16	16	0,5	16	I	149B3464	34
150	10/16	16	13	16	0,5	16	I	149B3465	45
200	10	10	10	10	0,5	10	I	149B3466	57
250	10	10	10	10	0,5	10	I	149B3467	92
300	10	10	10	10	0,5	10	I	149B3468	137

Option :

. Plate lifting from DN 65 to 300

. Drain plug for DN 40 & DN 50

* Flanges drilled 4 and 8 holes

Important notice :

The indicated pressure for the different categories of fluids (L1/L2/G1/G2) is under no condition a guarantee of use.

Therefore, it is essential to validate the use of products under given operating conditions. The operating instructions are available on our website www.socla.com or by requesting from our sales department.

Technical features

Operating temperature	-10 °C to 70 °C
Permissible operating pressure (PFA) in water	See table above
Maximum permissible pressure (PS) other mediums	See table above
Connection	Flanges drilled PN (see table)
Mediums	Waste water, clear water

Nomenclature and materials

N°	Description	Materials	EURO	ANSI
1	Body	Cast iron/Epoxy int/ext	DN 40-50 EN -GJL 250 DN upper EN-GJS-400.15	ASTM A 48 35 B ASTM A 536 65-45-12
2	Plug	Brass	CuZn39Pb3	
3	Cover	Cast iron/Epoxy	DN 40-50 EN -GJL 250 DN upper EN-GJS-400.15	ASTM A 48 35 B ASTM A 536 65-45-12
4	Plate		DN 40-50 : Cast iron NBR overmoulding DN upper : Ductile NBR overmoulding	
5	Stem	Brass	CuZn39Pb3	
6	Seal	NBR		
7-9	Washer	Stainless steel	GX5CrNi19-10	AISI 304
8	Bolts & nuts	Stainless steel	GX5CrNi19-10	AISI 304

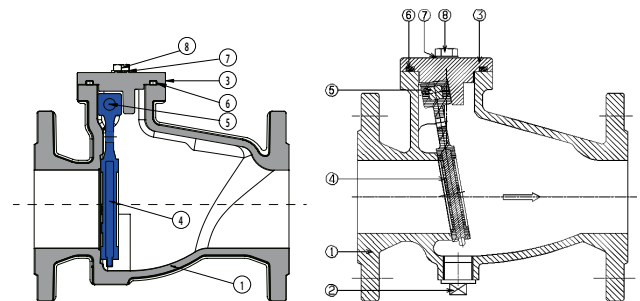

DN 40 and 50

DN 65 to 300

Approvals



International construction Standards :

Directive 2014/68/UE

Flange drilling according to EN 1092-2

Overall dimensions according to EN558-1 series 48

Application

The full flow of the fluid guarantees optimum use in sewage or clear water lifting and treatment plants. The design of its obturator, without blocking, allows its use in technical fire-fighting networks.

For all other applications, please contact us.

Installation

Installation :

Before putting valve into operation, check that:

- the working conditions are compatible with the details given on the identification plate, the instruction notice and the manufacturer's detail,
- the valve works effectively when tried (carry out a few opening and closing operations of the closing system),
- the valve is free-pollution inside.

On a new installation or after maintenance, the circuit must be rinsed with the valve completely open in order to remove solid matter which may damage the internal parts of the valve.

Commissioning :

The installation should be put under pressure progressively to avoid damage which might occur to internal components.

Make sure that when flow stops the valve maintains pressure well and that there is no water-hammer which might damage the valve or installation.

If there is water-hammer, an anti-water hammer system must be added to the installation.

During a prolonged stoppage, a change in the state of the fluid may result in damage when the installation is brought back into service (solidification...).

Establish an adequate procedure program for cleaning the system.

Maintenance

• Dismanteling :

1. Unscrew the cap retaining screw assembly (N°5)
2. Remove the cap (N°2)
3. Remove the plate (N°3)
4. Inspect the surface condition of the plate, clean or replace it if necessary.

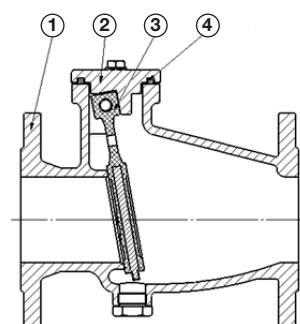

• Reassembly :

1. Insert the plate (N°3) into the body (N°1)
2. Place the O-ring (N°4) on the bonnet (N°2)
3. Position the cap and tighten the screws (N°5) alternately with a suitable tool.
4. Once the operation has been completed, start up the installation and make sure that there are no leaks between the cap and the body.

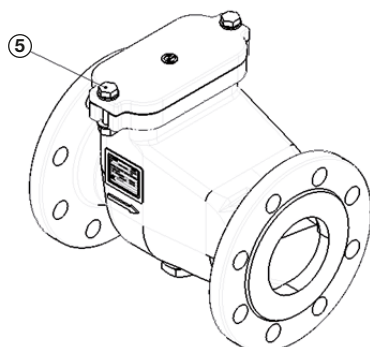

Operation

Direction for use :

- Solid line: Valve completely open

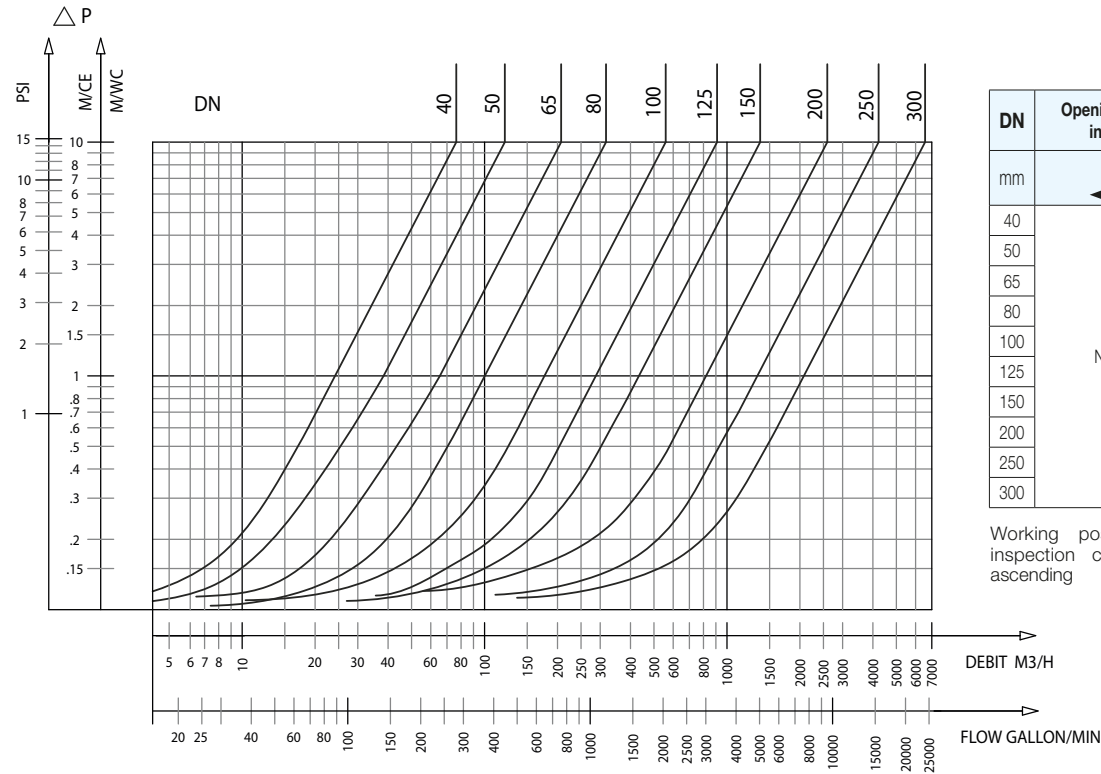

DN	Opening pressure in mm/CE	Kv	ζ
mm		m ³ /H	
40	Near to 0	76,45	0,70
50		121,2	0,68
65		207,85	0,66
80		317,30	0,65
100		559,60	0,51
125		910,90	0,47
150		1371,30	0,43
200		2593,30	0,38
250		4222,20	0,35
300		6567	0,30

Working position : horizontal with inspection cover upside, or vertical ascending

405 - Headloss chart

Sizing

DN	L	H
mm	mm	mm
40	180	89
50	200	95,5
65	240	122
80	260	140
100	300	152
125	350	162
150	400	180
200	500	205
250	600	255
300	700	293

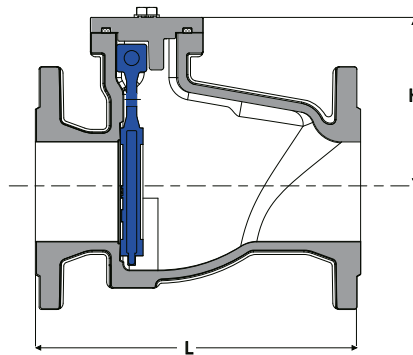

DN40 and 50

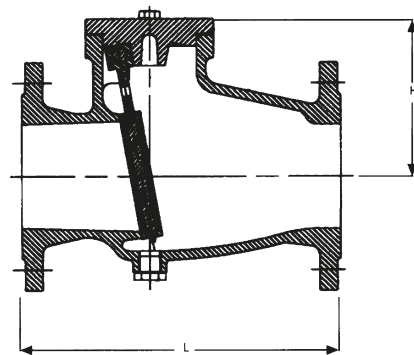

DN65 to 300

The descriptions and photographs contained in this product specification sheet are supplied by way of information only and are not binding.

Socla reserves the right to carry out any technical and design improvements to its products without prior notice. Warranty : All sales and contracts for sale are expressly conditioned on the buyer's assent to Socla terms and conditions found on its website at www.socla.com. Socla hereby objects to any term, different from or additional to Socla terms, contained in any buyer communication in any form, unless agreed to in a writing signed by an officer of Socla.



A WATTS Brand

Socla sas

365 rue du Lieutenant Putier • 71530 Virey-Le-Grand • France
 Tel. +33 03 85 97 42 00 • Fax +33 03 85 97 42 42
contact@wattswater.com • www.socla.com
 ISO 9001 version 2015 / ISO 18001