

30

Non-return foot valve

B System

Technical Data Sheet



Description

The non-return valves 30 consists of a self-cleaning ball lifted by the fluid and guided to a lateral seat, completely out of the way. This system provides a full-flow, even with loaded fluids, without any risk of blockage.

- Vertical position
- Minimum head loss
- Silent, robust
- Non incrustating materials
- Sealing ensured by elastomer seal fixed on the seat



30

Non-return foot valve - B System

DN	PFA in	PS in bar				Cat.	Ref.	Weight Kg
		L1	L2	G1	G2			
1	25	10	10	x	x	4.3	149B2322	1,9
1 1/4	32	10	10	x	x	4.3	149B2323*	2,4
1 1/2	40	10	10	x	x	4.3	149B2324*	3,2
2	50	10	10	x	x	4.3	149B2325	4,1
2 1/2	65	10	10	x	x	4.3	149B2327*	6,5
3	80	10	10	x	x	4.3	149B2368*	12,9

Galvanised steel strainer - Cylindrical perforation

Important notice :

The indicated pressure for the different categories of fluids (L1/L2/G1/G2) is under no condition a guarantee of use. Therefore, it is essential to validate the use of products under given operating conditions. The operating instructions are available on our website www.socla.com or by requesting from our sales department.

Technical features

Operating temperature	-10 °C to 80 °C
Permissible operating pressure (PFA) in water	See table above
Maximum permissible pressure (PS) other mediums	See table above
Connection	Female, BSP
Mediums	Thick liquids, viscous liquids, loaded liquids

Nomenclature and materials

N°	Description	Materials	EURO	ANSI
1	Body	Cast iron / Epoxy	EN-GJL-250	ASTM A 48 35 B
2	Ball	Density 1,30 Resin		
3	Seal	DN 1"1/2 Others DN	NR	NR
4	Screw	Stainless steel A2	X10CrNi18-10	AISI 304
5	Strainer	DN 1" and 2" Others DN	Cast iron / Epoxy Galvanised steel	EN-GJL-250 ASTM A 48 35 B
6	Nut	Stainless steel A2	X10CrNi18-10	AISI 304

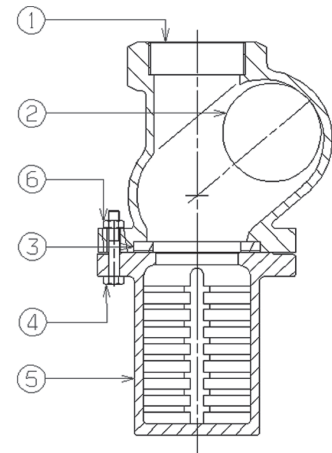

Approvals



International construction Standards :
Directive 2014/68/UE
Thread connection according to ISO 228

Application

Viscous liquids, loaded liquids, wasted water.
This “all-purpose” range is also suitable in lifting of aggressive liquids and construction sites sanitation.

Operation

Direction for use :

- Solid line: Valve completely open

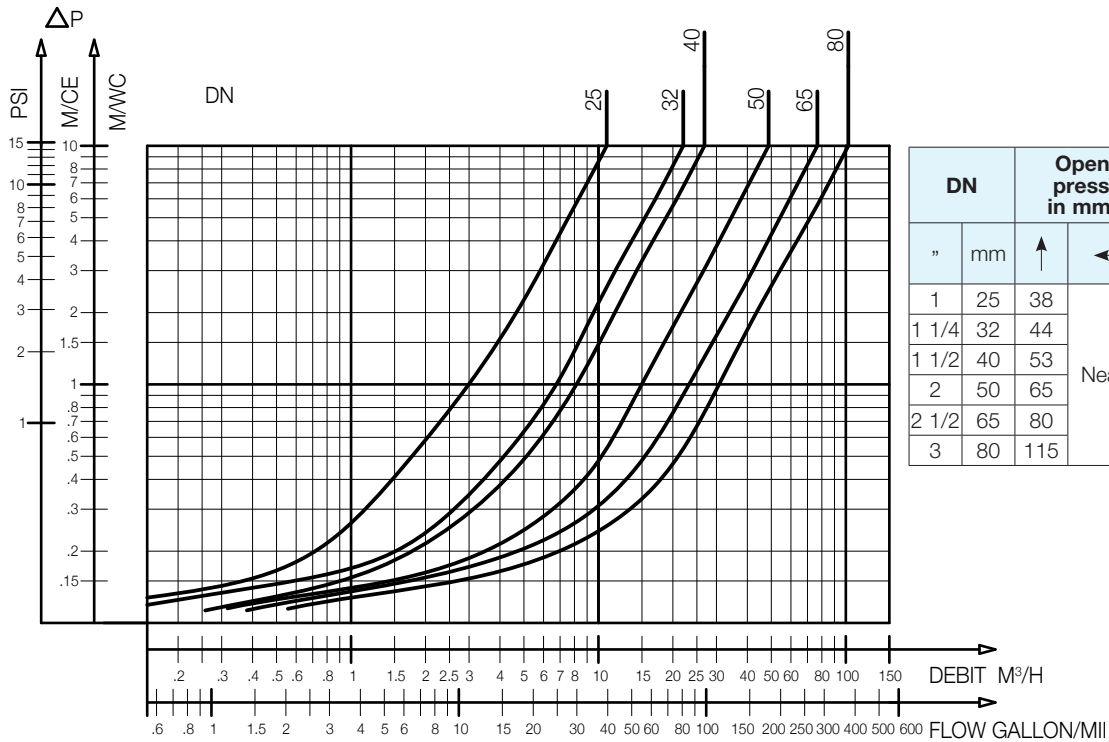

30 - Headloss chart

Sizing

A		B	C
"	mm	mm	mm
1	26/34	104	183
1 1/4	33/42	119	191
1 1/2	40/49	137	204
2	50/60	157	256
2 1/2	66/76	179	240
3	80/90	214	303

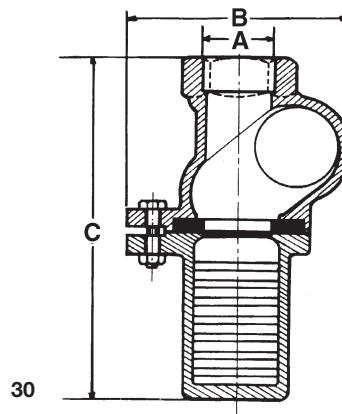

The descriptions and photographs contained in this product specification sheet are supplied by way of information only and are not binding.

Socla reserves the right to carry out any technical and design improvements to its products without prior notice. Warranty : All sales and contracts for sale are expressly conditioned on the buyer's assent to Socla terms and conditions found on its website at www.socla.com. Socla hereby objects to any term, different from or additional to Socla terms, contained in any buyer communication in any form, unless agreed to in a writing signed by an officer of Socla.



A WATTS Brand

Socla sas

365 rue du Lieutenant Putier • 71530 Virey-Le-Grand • France

Tel. +33 03 85 97 42 00 • Fax +33 03 85 97 42 42

contact@wattswater.com • www.socla.com

ISO 9001 version 2015 / ISO 18001