

WAFER BUTTERFLY VALVE



**BUREAU
VERITAS**



DNV



**Lloyd's
Register**

PED 97/23/CE



Size : DN 32 to 1400 mm
Ends : Between flanges PN10/16 and ISO PN20 ANSI150
Min Temperature : - 10°C (with EPDM seat)
Max Temperature : + 110°C (with EPDM seat)
Max Pressure : 16 Bars up to DN300
Specifications : Long neck for isolation
 Wafer type
 Full crossing stem
 ISO 5211 mounting pad

Materials : Ductile iron EN GJS 500-7 body

WAFER BUTTERFLY VALVE

SPECIFICATIONS :

- Long neck for isolation
- ISO 5211 mounting pad
- Wafer type
- Between flanges ISO PN10/16 from DN32/40 to 400 and ISO PN20 ANSI150 from DN40 to 400 (over on request)
- Between flanges ISO PN10 from DN450 to DN 1400
- Full crossing stem
- Removable seat
- Stainless steel disc up to DN100
- Ductile iron epoxy coated disc +/- 40 µ from DN125 to 300, ductile iron rilsan coated disc +/- 300 µ over for 1150 and 1152 types
- 9 positions lever with locking device up to DN200 , stop in all positions but non lockable from DN250 to 300
- Rilsan coated body color RAL 5024 , 250-300 microns thickness
- Stem extension 75 mm length (option)
- Square lever 30x30 mm for special key (option)

USE :

- Fluids : Depending of the seat
- Min and max Temperature Ts : Depending of the seat
- Max Pressure Ps : 16 bars up to DN300 , 10 bars over

RANGE :

- With lever from DN 32 to DN 300
- Naked stem from DN 350 to DN1400
- IP65 gear box possible (**Ref. 1197**) from DN 32 to DN 1400
- IP65 chain gear box (**Ref. 1194**) from DN 32 to DN 500
- On request, stem extension with special length (**Ref. 98665**)
- On request, stainless steel handle and bolting **Ref. 9831250-9831264**

ENDS :

- Between flanges ISO PN10/16 from DN32/40 to 400 and ISO PN20 ANSI150 from DN40 to 400
- Between flanges ISO PN10 from DN450 to DN 1400

TORQUE VALUES (in Nm with safety coefficient of 30 % included) at 10 Bars :

DN	32/40	50	65	80	100	125	150	200	250	300	350	400
Torque (Nm)	9	11	20	29	47	82	130	210	360	475	760	1300

DN	450	500	600	700	750	800	900	1000	1100	1200	1300	1400
Torque (Nm)	1600	2340	3300	4600	5800	7400	11000	13600	14200	16400	17800	19200

FLOW COEFFICIENT Kvs (m³ / h) :

DN	32/40	50	65	80	100	125	150	200	250	300	350	400
Kvs (m ³ /h)	70	109	200	334	551	901	1427	2383	3825	5659	8177	10659

DN	450	500	600	700	800	900	1000	1200	1300	1400
Kvs (m ³ /h)	12562	16021	22737	32443	43263	53873	64407	97341	119770	129808

WAFER BUTTERFLY VALVE

HEAD LOSS GRAPH :

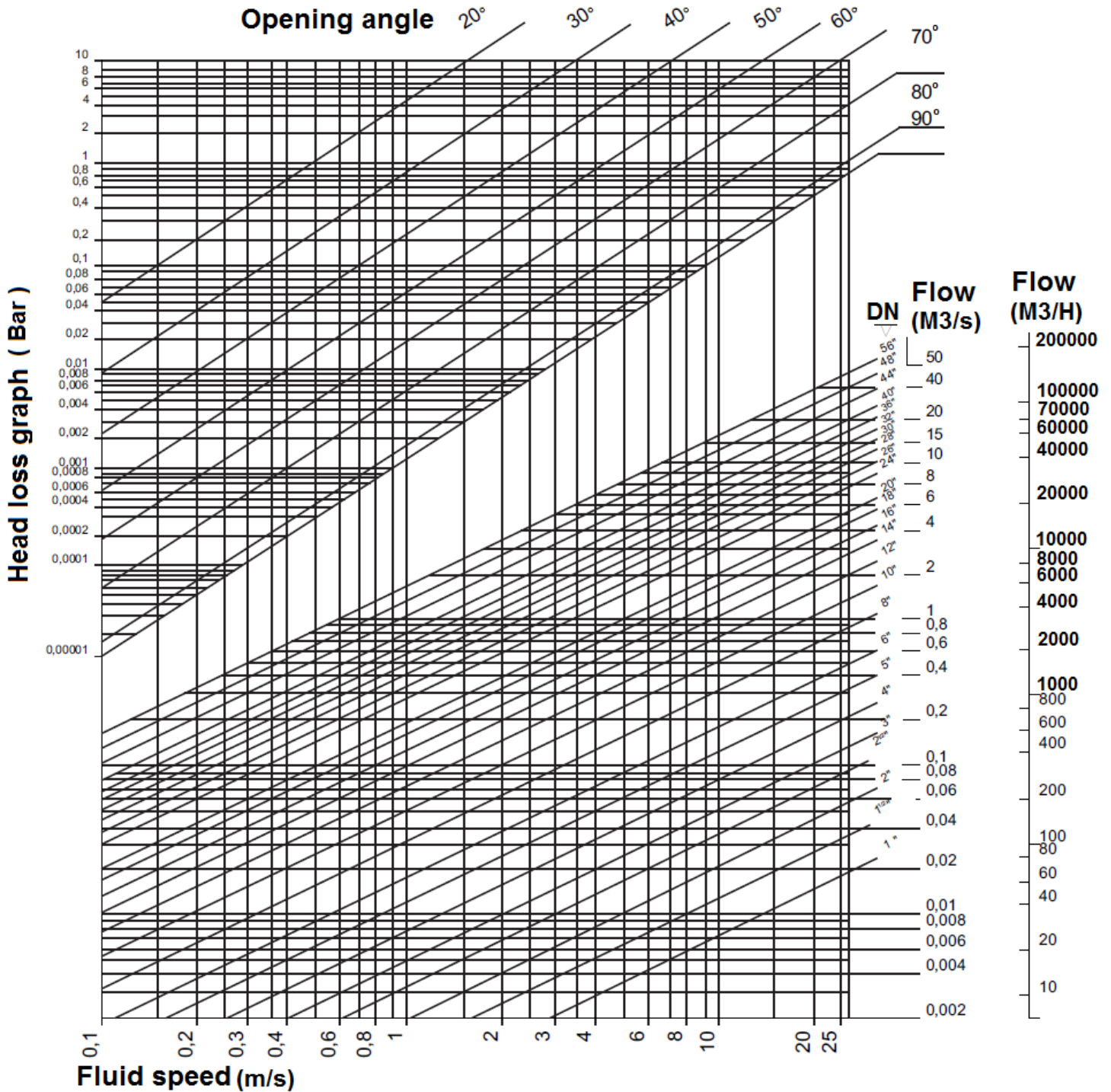

WAFER BUTTERFLY VALVE

COMPATIBILITY :

Types	Elastic ring	Min/Max Temperature	Applications	Not Advisable
1150	EPDM	-10°C + 110°C	Cold and hot water	Hydrocarbon, steam, gas, acids, oil, freon
1151 / 1152	NBR	-10°C + 90°C	Non aromatic hydrocarbon, fuel, water, natural gas, grease, oil, compressed air, glycol	Gas in atmospheric condition, petrol, premium gasoline, acetone, acetic acid and solvent
1153	EPDM	-10°C + 110°C	Cold and hot water, sea water, alcohol, hydroxyd of soda, demineralized water, mercury, alcalins	Hydrocarbon, steam, gas, acids, oil, Freon
1154	FKM	-5°C + 180°C	Acids, grease, hydrocarbon, petrol, premium gasoline, Argon, glycerin, oil, carbon dioxide, biogas	Steam and hot water (130°C max), freon, amoniac, acetylene
1156	White NBR	-10°C + 90°C	Oil, grease	Gas in atmospheric condition, petrol, premium gasoline, acetone, acetic acid and solvent
1157	SILICONE	-30°C + 150°C	High temperature, oil, acids, air or inerted gas	Solvent, steam and hot water(100°C max)
1158	NBR	-10°C + 90°C	Sea water	Gas in atmospheric condition, petrol, premium gasoline, acetone, acetic acid and solvent

The above information are given with sincerity and are result of a long experience.
 Each case is particular and they can not engage our responsibility.
 We advise to proceed with real condition use trials.

OTHER MODELS ON REQUEST :

BODY	STEM	DISC	ELASTIC RING	HANDLING
Cast iron EN GJL-250	SS 420	Cast iron EN GJL-250	EPDM	Aluminium lever
Ductile iron EN GJS-500-7	SS 304	Ductile iron ENGJS-500-7	EPDM HT	S.S. lever
ASTM A216 WCB	SS 316	ASTM A216 WCB	NBR	Square
SS 304	Hastelloy	SS 304	FKM	Gear box
ASTM A351 CF8M	Other alloy	ASTM A351 CF8M	Hypalon®	S.S. gear box
Bronze aluminium		S.S. polish	Silicone	Chain gear box
Aluminium		Aluminium	Silicone food	Electric
Bronze		Cupro aluminium	Silicone steam	Pneumatic
Other alloy		Bronze	White NBR	Stem extension on request
Special		Uranus B6	Carbox. NBR	
Coated		Monel	Natural rubber	
Dry cleaned		Inconel	Neoprene	
Special painting		Hastelloy	Nordel	
		Duplex	Glued seat	
	Halar coated	Vulcanized		

WAFER BUTTERFLY VALVE

PRESSURE / TEMPERATURE GRAPH (STEAM EXCLUDED) :

- EPDM elastic ring for Ps 16 BAR DN40-300 :

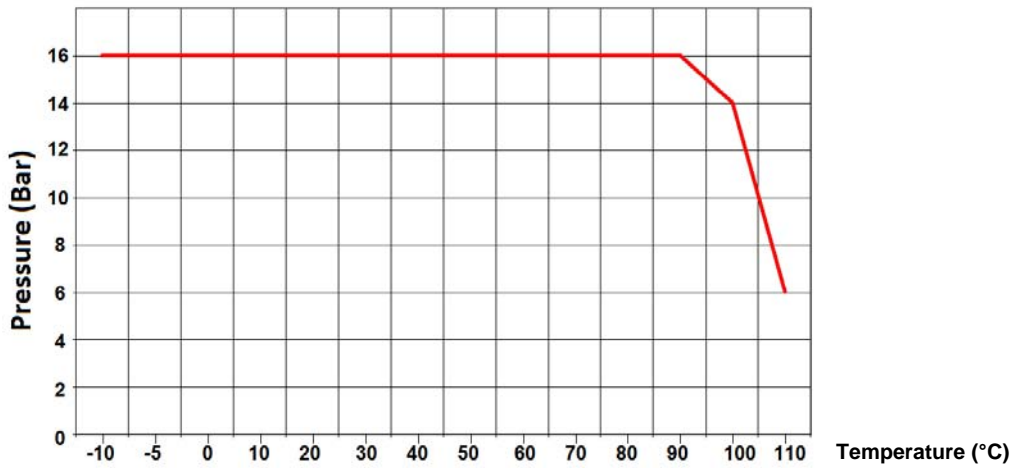

- EPDM elastic ring for Ps 10 BAR DN350-1200 :

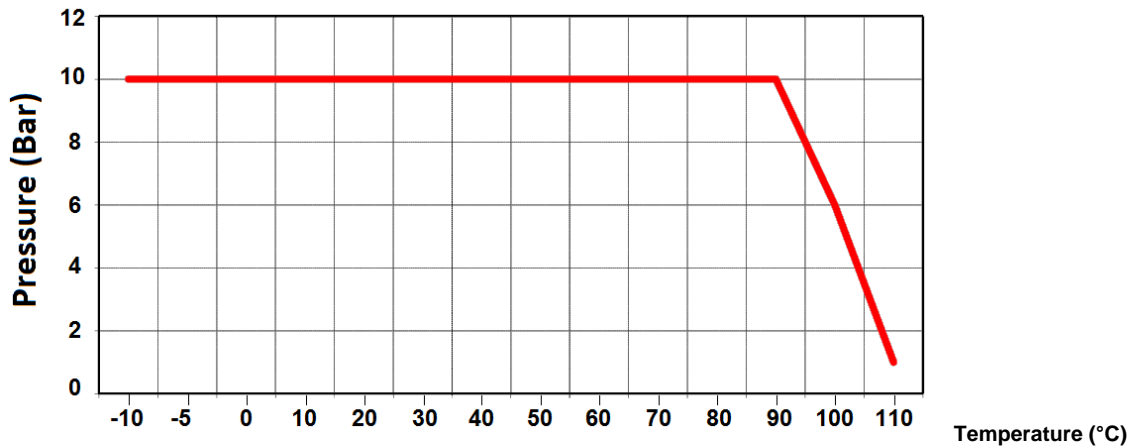

- NBR elastic ring for Ps 16 BAR DN40-300 :

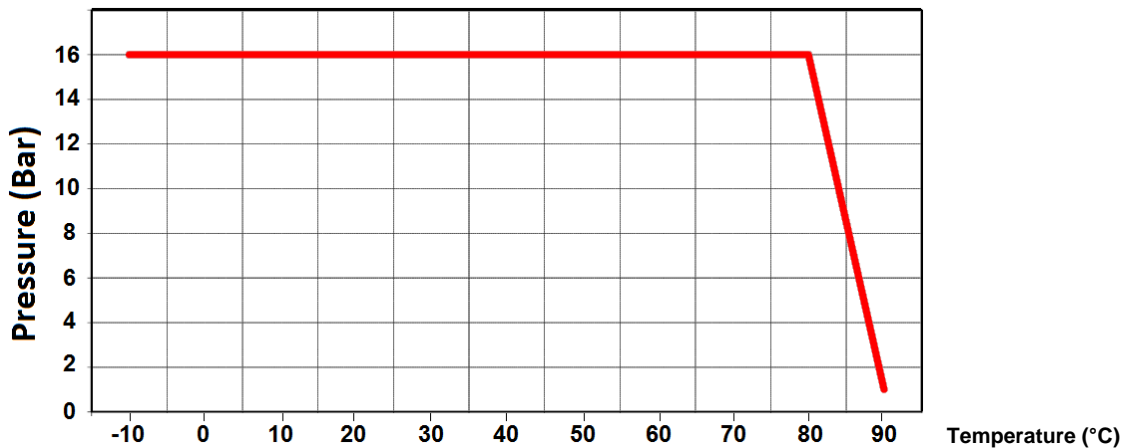

WAFER BUTTERFLY VALVE

PRESSURE / TEMPERATURE GRAPH (STEAM EXCLUDED) :

- *NBR elastic ring for Ps 10 BAR DN350-1200 :*

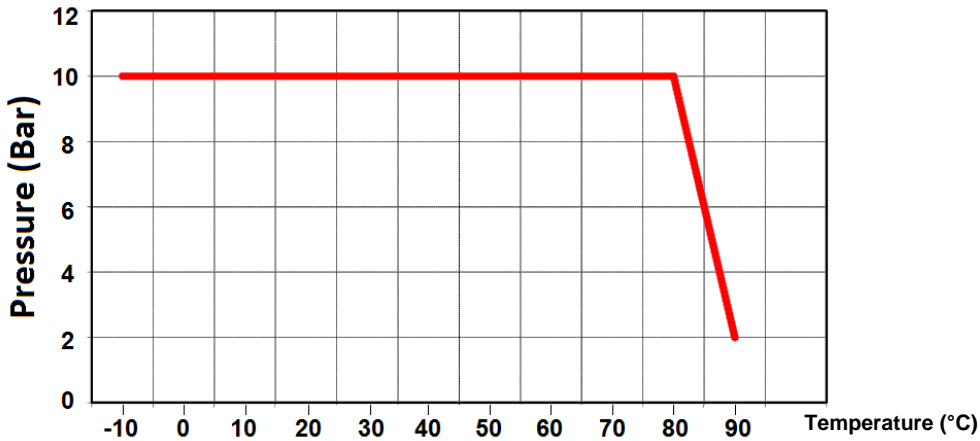

- *FKM elastic ring for Ps 16 BAR DN40-300 :*

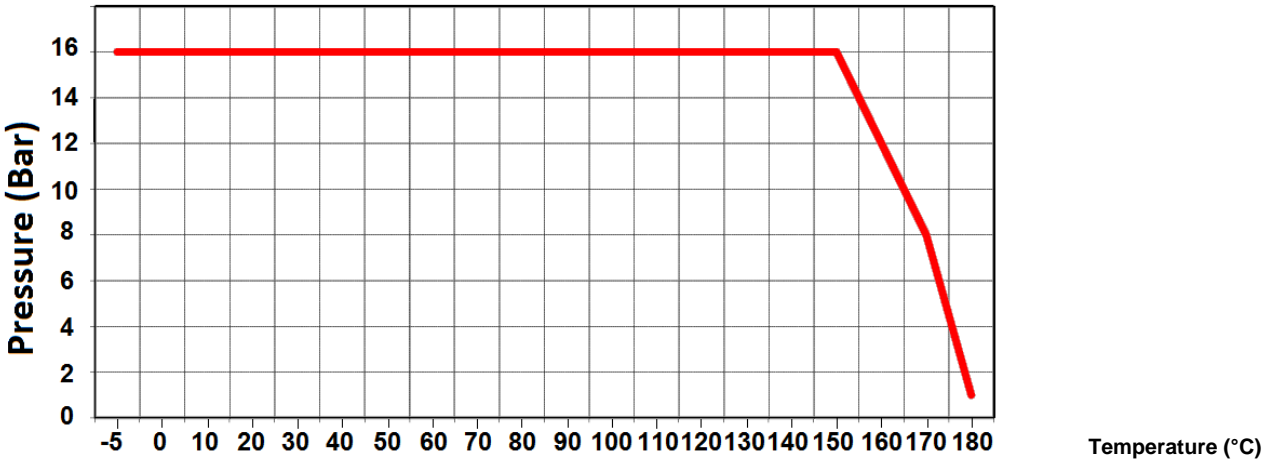

- *FKM elastic ring for Ps 10 BAR DN350-1200 :*

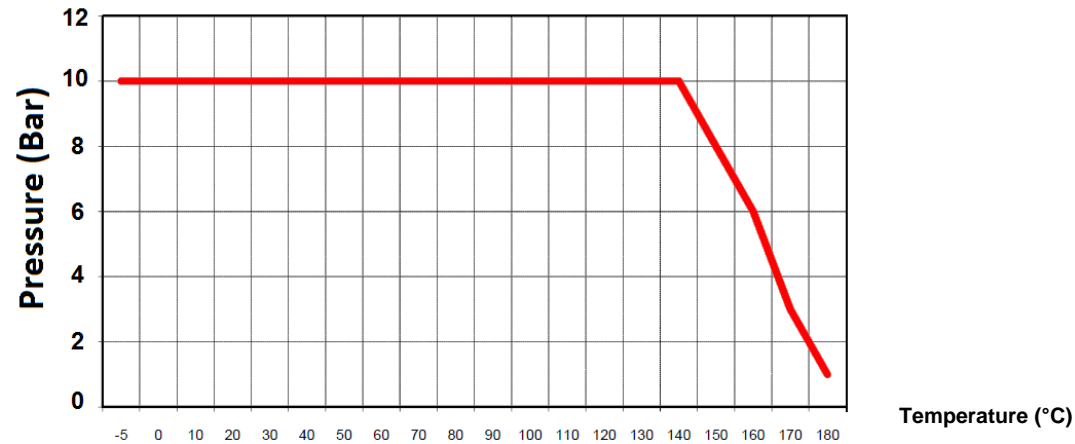

WAFER BUTTERFLY VALVE

PRESSURE / TEMPERATURE GRAPH (STEAM EXCLUDED) :

- *SILICONE elastic ring for Ps 16 BAR DN40-300 :*

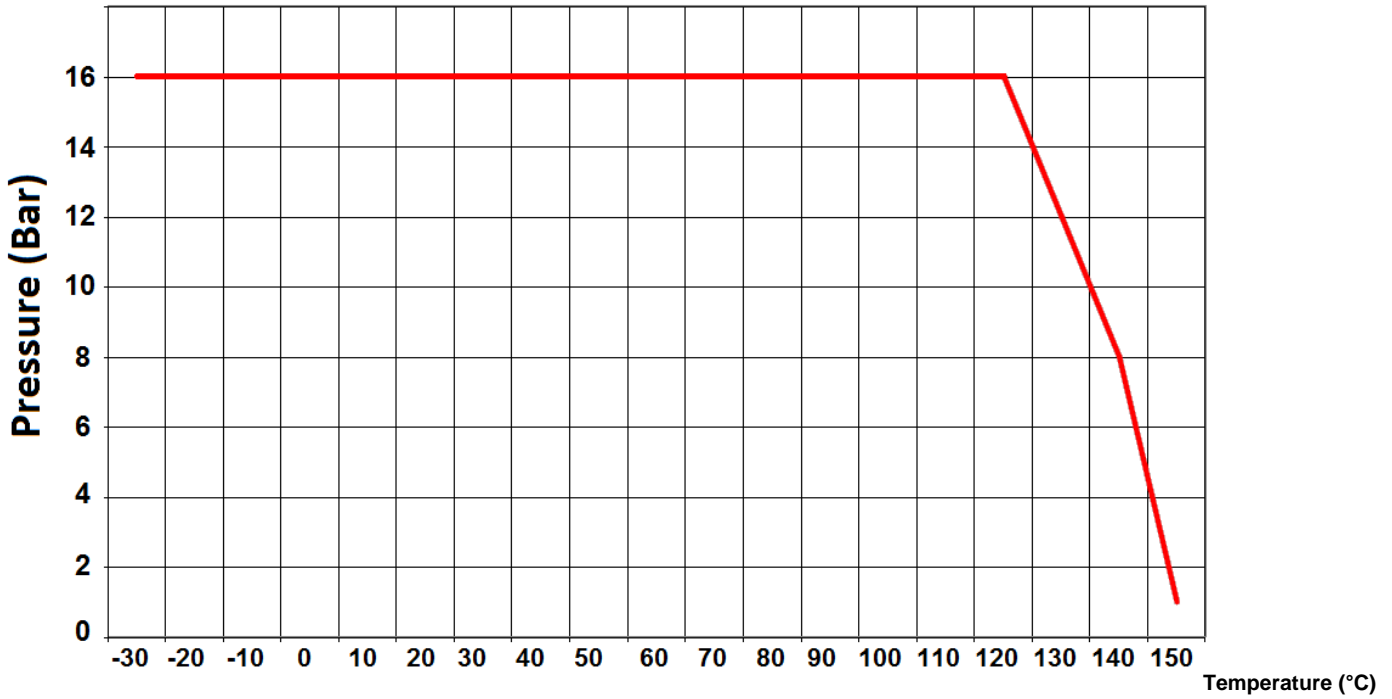

- *SILICONE elastic ring for Ps 10 BAR DN350-1200 :*

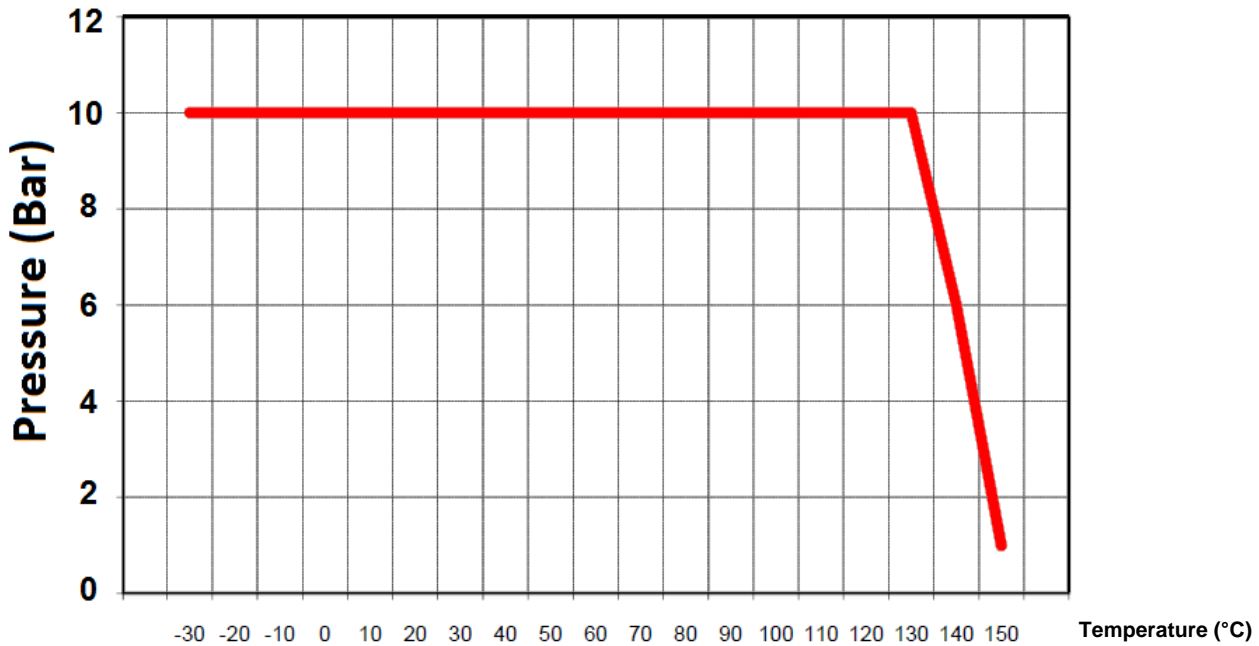

WAFER BUTTERFLY VALVE

MATERIALS DN 32 - 200 :

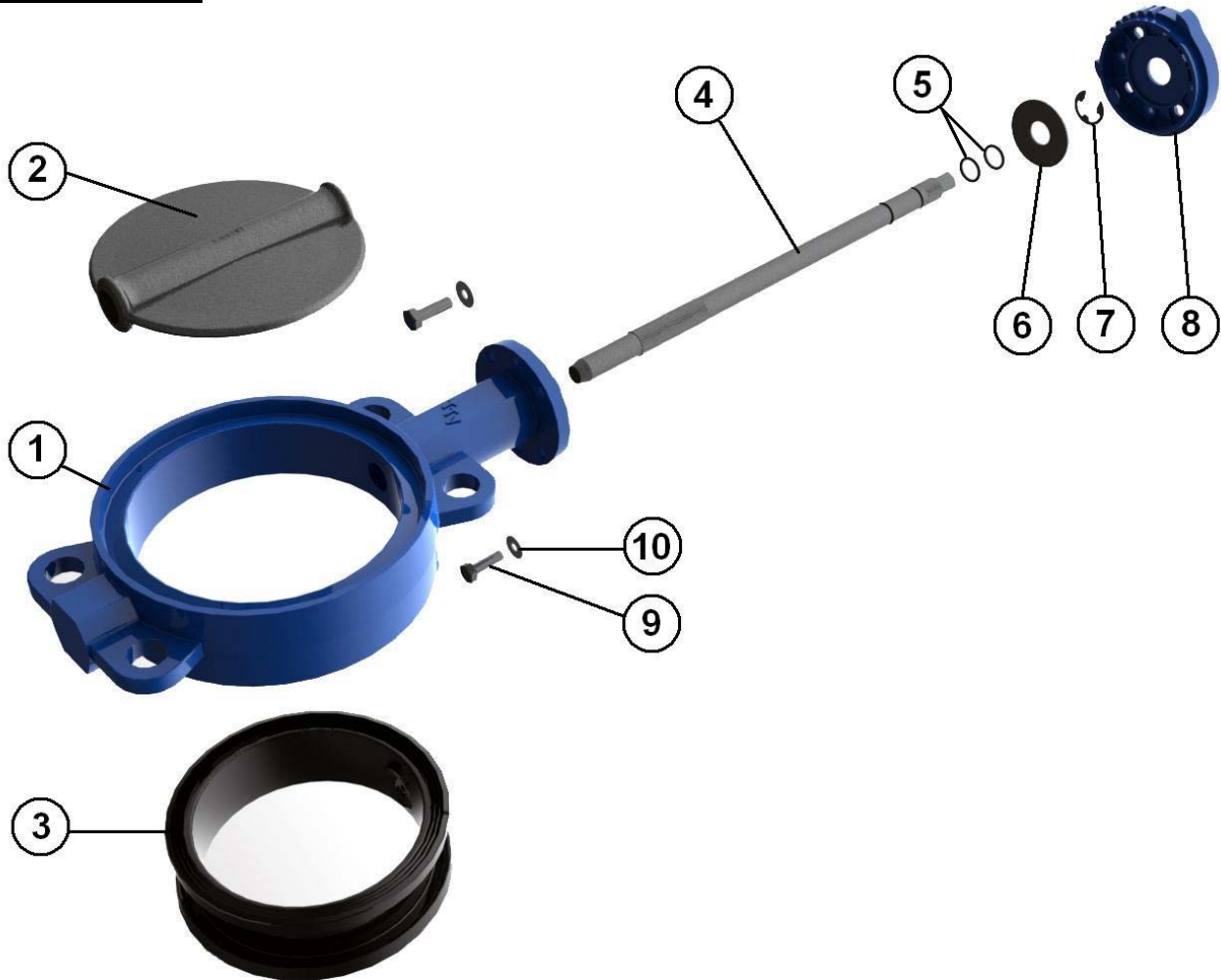

		Materials								
Item	Designation	1150	1151	1152	1153	1154	1156	1157	1158	
1	Body	Ductile iron EN GJS-500-7								
2	Disc DN32-100	ASTM A351 CF8M								Alu bronze
2	Disc DN125-200	ENGJS500-7	A351 CF8M	ENGJS500-7	ASTM A351 CF8M				Alu bronze	
3	Elastic ring	EPDM	NBR	NBR	EPDM	FKM	White NBR	SILICONE	NBR	
4	Stem	SS 420	SS 304	SS 420	SS 304	SS 304	SS 304	SS 304	SS 304	
5	O ring	EPDM	NBR	NBR	EPDM	FKM	NBR	EPDM	NBR	
6	Ring	Steel	Steel	Steel	Steel	Steel	Steel	Steel	Steel	
7	Circlips	Steel	Steel	Steel	Steel	Steel	Steel	Steel	Steel	
8	Plate	Aluminium	Aluminium	Aluminium	Aluminium	Aluminium	Aluminium	Aluminium	Aluminium	
9	Plate screw	5.6	5.6	5.6	5.6	5.6	5.6	5.6	5.6	
10	Washer	Steel	Steel	Steel	Steel	Steel	Steel	Steel	Steel	
	Lever	Aluminium								

WAFER BUTTERFLY VALVE

MATERIALS DN 250 - 400 :

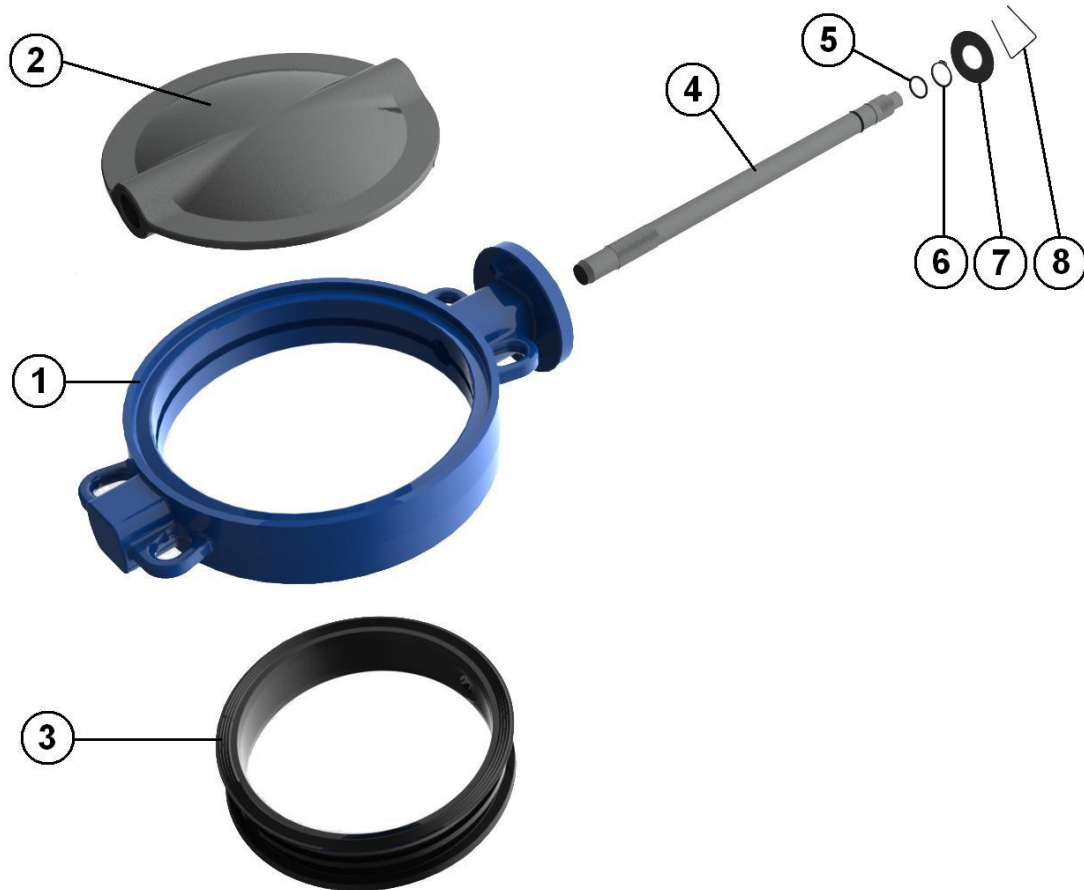

		Materials							
Item	Designation	1150	1151	1152	1153	1154	1156	1157	1158
1	Body	Ductile iron EN GJS-500-7							
2	Disc	ENGJS500-7	A351 CF8M	ENGJS500-7	ASTM A351 CF8M				Alu bronze
3	Elastic ring	EPDM	NBR	NBR	EPDM	FKM	White NBR	SILICONE	NBR
4	Stem	SS 420	SS 304	SS 420	SS 304	SS 304	SS 304	SS 304	SS 304
5	O ring	EPDM	NBR	NBR	EPDM	FKM	NBR	EPDM	NBR
6	Circlips	Steel	Steel	Steel	Steel	Steel	Steel	Steel	Steel
7	Ring	Steel	Steel	Steel	Steel	Steel	Steel	Steel	Steel
8	Spring	Steel	Steel	Steel	Steel	Steel	Steel	Steel	Steel
Lever (up to DN300)		Aluminium							

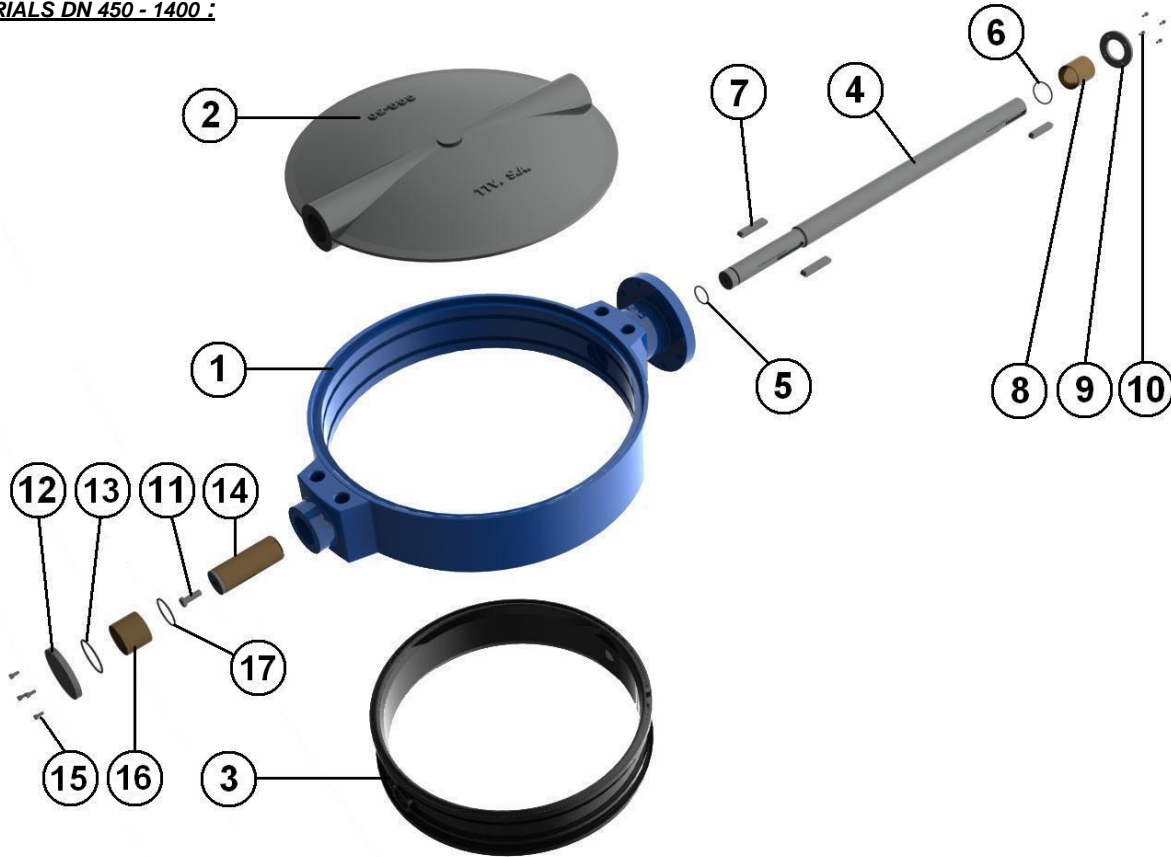
WAFER BUTTERFLY VALVE
MATERIALS DN 450 - 1400 :

		Materials							
Item	Designation	1150	1151	1152	1153	1154	1156	1157	1158
1	Body	Ductile iron EN GJS-500-7							
2	Disc	ENGJS500-7	A351 CF8M	ENGJS500-7	ASTM A351 CF8M				Alu bronze
3	Elastic ring	EPDM	NBR	NBR	EPDM	FKM	White NBR	SILICONE	NBR
4	Stem	SS 420	SS 304	SS 420	SS 304	SS 304	SS 304	SS 304	SS 304
5	O ring	EPDM	NBR	NBR	EPDM	FKM	NBR	EPDM	NBR
6	O ring	EPDM	NBR	NBR	EPDM	FKM	NBR	EPDM	NBR
7	Pin	ST - 60	ST - 60	ST - 60	ST - 60	ST - 60	ST - 60	ST - 60	ST - 60
8	Socket	BRONZE	BRONZE	BRONZE	BRONZE	BRONZE	BRONZE	BRONZE	BRONZE
9	Ring	F1110	F1110	F1110	F1110	F1110	F1110	F1110	F1110
10	Screw	5.6	5.6	5.6	5.6	5.6	5.6	5.6	5.6
11	Screw	5.6	5.6	5.6	5.6	5.6	5.6	5.6	5.6
12	Cap	F1110	F1110	F1110	F1110	F1110	F1110	F1110	F1110
13	O ring	EPDM	NBR	NBR	EPDM	FKM	NBR	EPDM	NBR
14	Socket	F1110	F1110	F1110	F1110	F1110	F1110	F1110	F1110
15	Screw	5.6	5.6	5.6	5.6	5.6	5.6	5.6	5.6
16	Socket	BRONZE	BRONZE	BRONZE	BRONZE	BRONZE	BRONZE	BRONZE	BRONZE
17	O ring	EPDM	NBR	NBR	EPDM	FKM	NBR	EPDM	NBR

WAFER BUTTERFLY VALVE

GEARBOX MATERIALS REF. 1197 :

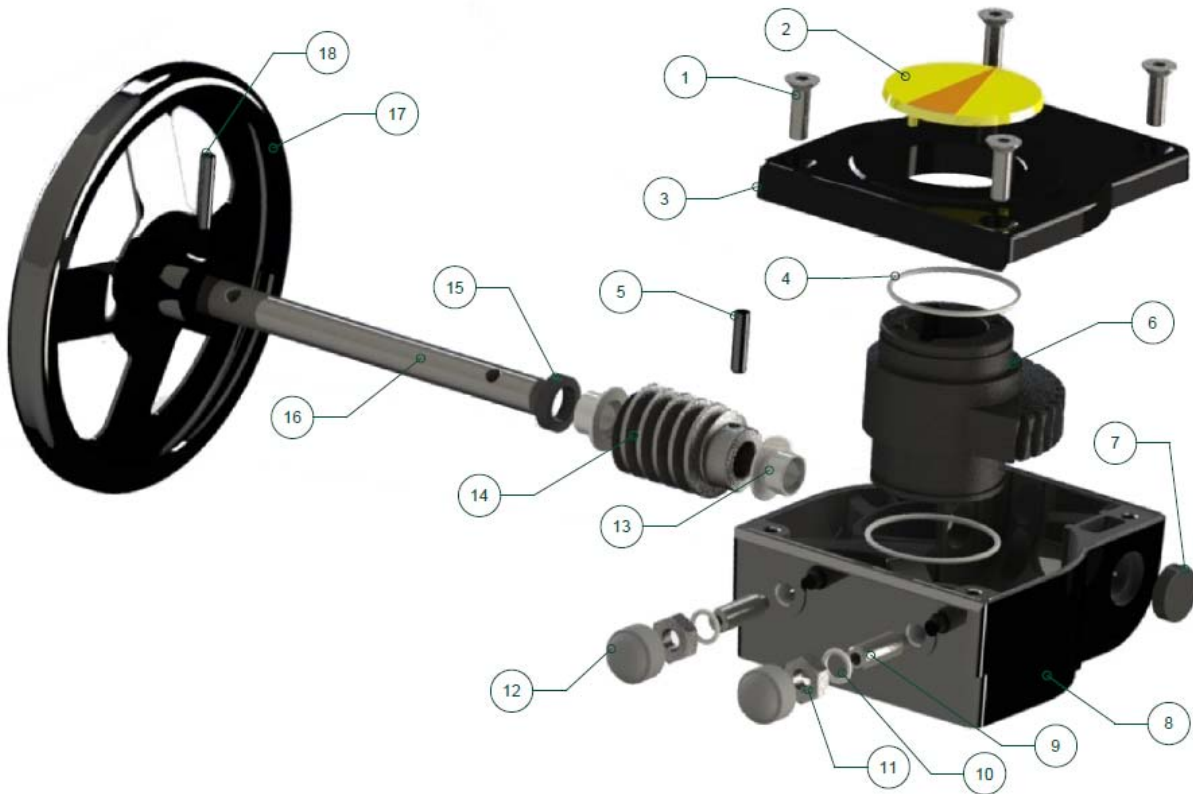

Item	Designation	Materials Ref. 1197
1	Screw	SS 304
2	Pointer	Polypropylene
3	Bonnet	Aluminium
4	O ring	NBR
5	Pin	Carbon steel
6	Quadrant	Ductile iron EN GJS-400-15
7	Gasket	NBR
8	Body	Aluminium
9	Adjusting bolt	Carbon steel
10	Washer	Galvanized steel
11	Nut	Galvanized steel
12	Cap	NBR 70
13	Bushing	Bronze
14	Worm	Carbon steel 45
15	Gasket	NBR
16	Stem	Carbon steel 45
17	Handwheel	Carbon steel
18	Pin	Carbon steel

WAFER BUTTERFLY VALVE

SIZE ISO PN10 (in mm) :

- Valves DN 32 - 400 :

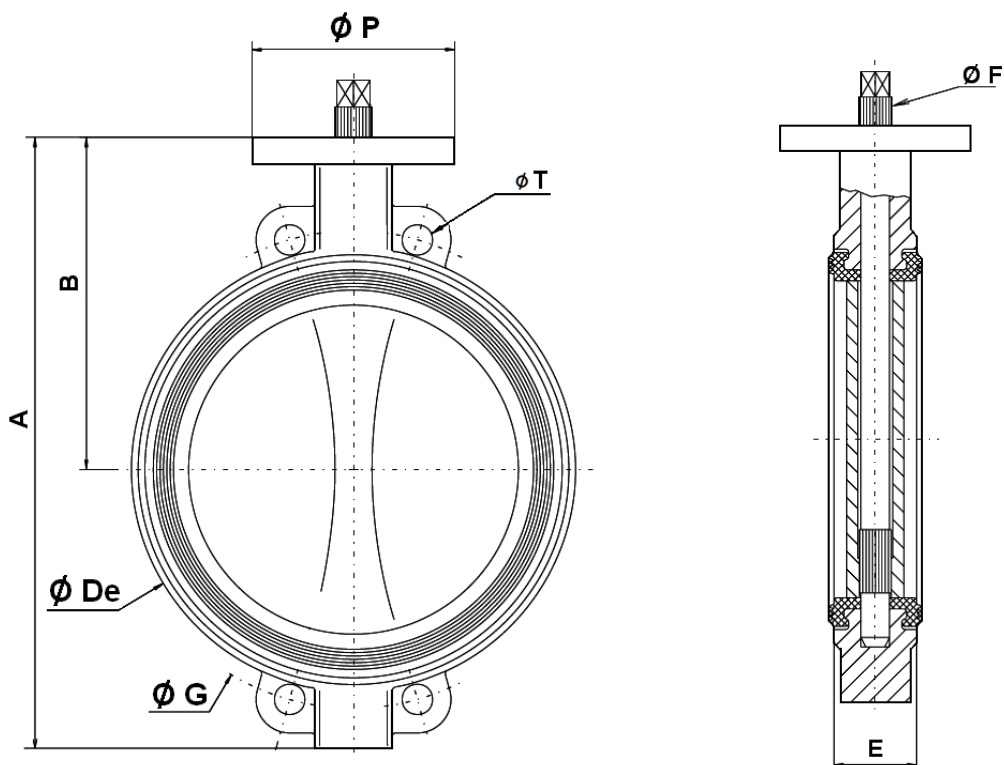

DN	32/40	50	65	80	100	125	150	200	250	300	350	400
A	206	228	243	266	294	324	349	438	461	523	582	645
B	140	156	162	170	185	207	216	256	248	280	300	340
Ø De	82	102	119	135	155	185	208	270	328	381	437	486
E	33	43	46	46	52	56	56	60	68	78	78	102
Ø F	10.5	10.5	14.5	16.5	16.5	18.5	18.5	22.5	25.5	30.5	30.5	35.5
Ø G	110	125	145	160	180	210	240	295	350	400	460	515
Ø P	88	88	88	88	88	105	105	105	150	150	170	170
Ø T	18	18	18	18	18	18	23	23	23	23	23	27
Weight (Kg)	2.46	3.66	4.4	4.6	6	7.6	9.2	14.7	24.7	33	39	52

WAFER BUTTERFLY VALVE

LEVERS SIZE (in mm) :

DN 32 – 200 :

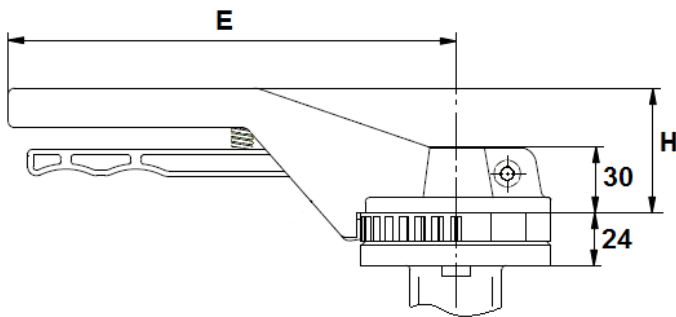

DN	32-100	125-200
E	205	330
H	57	70
Ø P	88	105

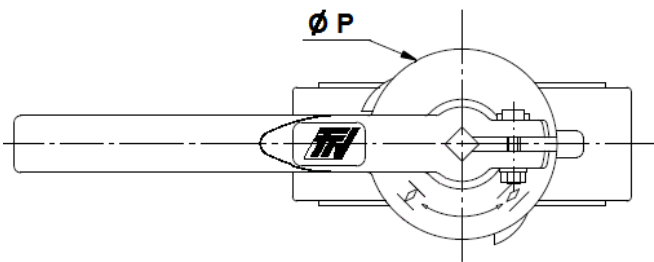

DN 250 – 300 :

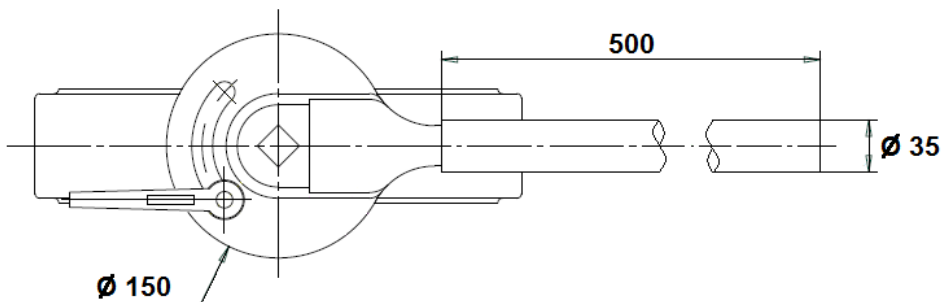
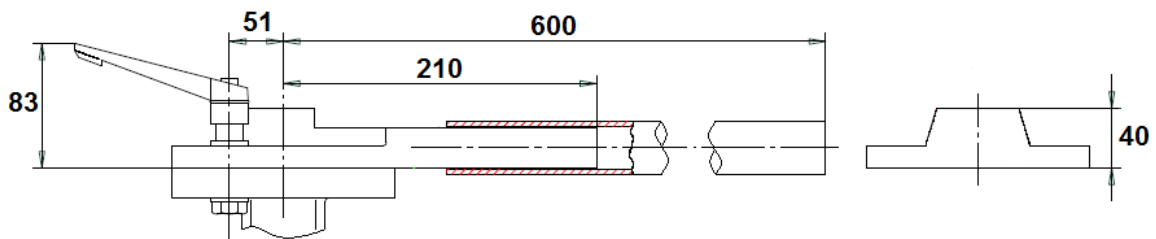

WAFER BUTTERFLY VALVE

SIZE ISO PN10 (in mm) :

- Valves DN 450 - 1400 :

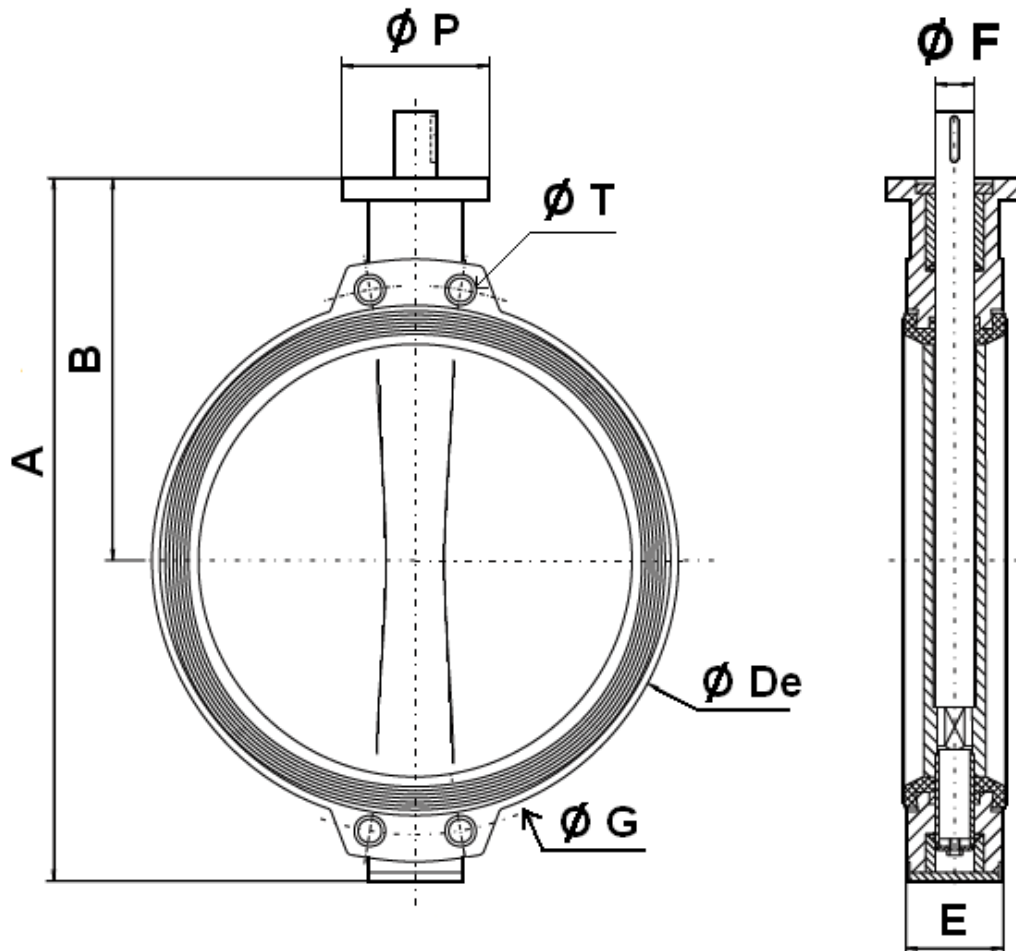

DN	450	500	600	700	750	800	900	1000	1100	1200	1300	1400
A	738	822	965	1100	1150	1248	1325	1457	1580	1720	1910	1990
B	394	440	507	575	600	655	685	754	815	873	1005	1025
Ø De	538	595	695	804	860	911	1010	1124	1225	1330	1460	1530
E	114	127	154	165	190	190	203	216	216	254	360	360
Ø F	50	50	60	60	65	65	80	80	80	100	120	120
Ø G	565	620	725	840	900	950	1050	1160	1270	1380	-	1590
Ø P	175	175	250	300	300	300	300	300	300	300	350	350
Ø T	M24	M24	M27	M27	M30	M30	M30	M33	M33	M36	-	M39
Weight (Kg)	87	117	177	258	296	330	505	661	840	1020	1650	1900

WAFER BUTTERFLY VALVE

SIZE ISO PN10 (in mm) :

- Valves with gear box DN 32 - 400 :

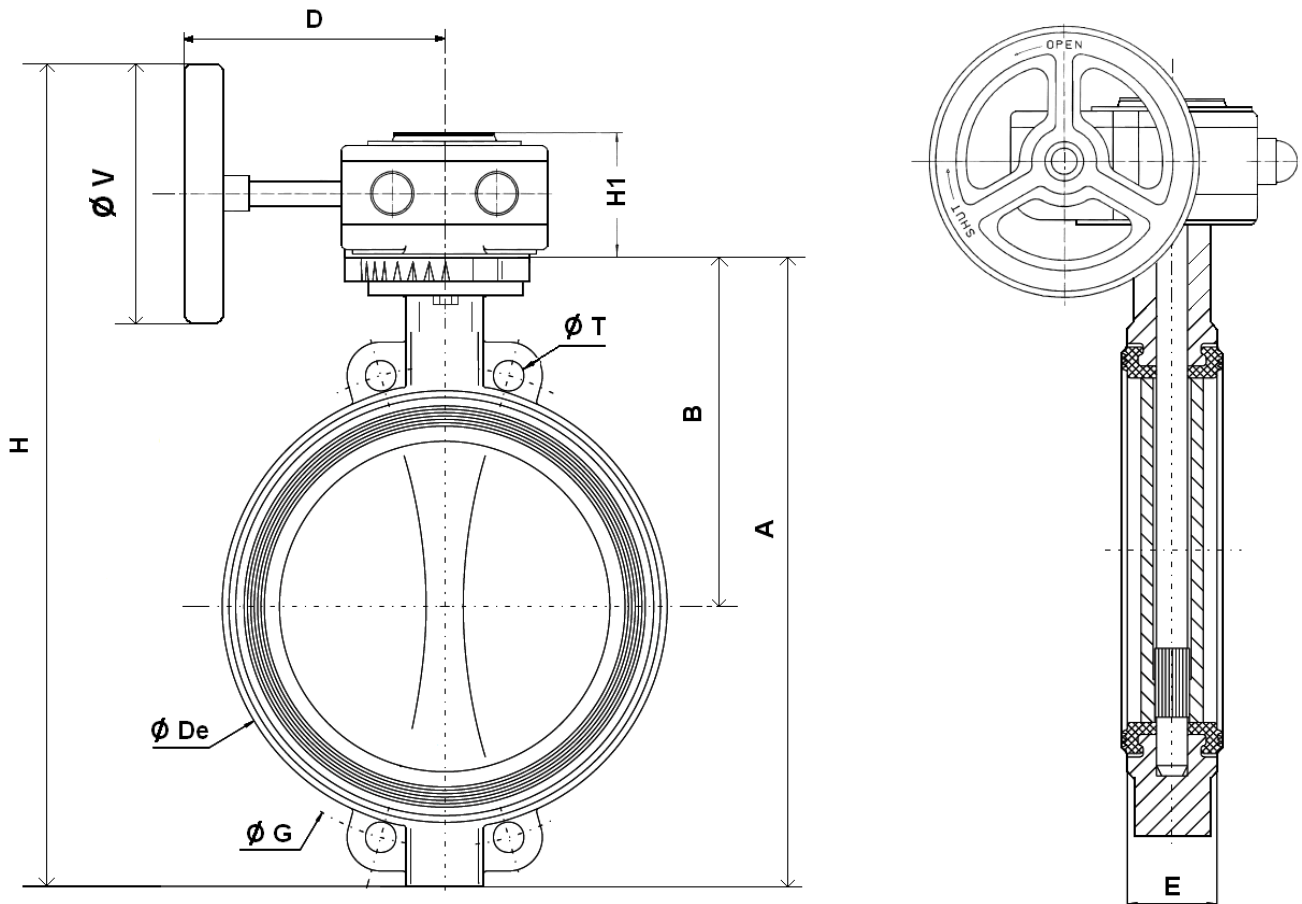

DN	32/40	50	65	80	100	125	150	200	250	300	350	400
A	206	228	243	266	294	324	349	438	461	523	582	645
B	140	156	162	170	185	207	216	256	248	280	300	340
Ø De	82	102	119	135	155	185	208	270	328	381	437	486
D	120	120	120	120	120	136	136	136	223	223	345	345
E	33	43	46	46	52	56	56	60	68	78	78	102
H	304	326	341	364	392	452	477	566	647	709	831	894
H1	58	58	58	58	58	58	58	58	74	74	98	98
Ø G	110	125	145	160	180	210	240	295	350	400	460	515
Ø T	18	18	18	18	18	18	23	23	23	23	23	27
Ø V	140	140	140	140	140	200	200	200	300	300	400	400
Weight (Kg)	3.81	5.01	5.75	5.95	7.35	9.35	10.95	16.45	28.7	37	48.5	61.5

WAFER BUTTERFLY VALVE

SIZE ISO PN10 (in mm) :

- Valves with gear box DN 450 - 1400 :

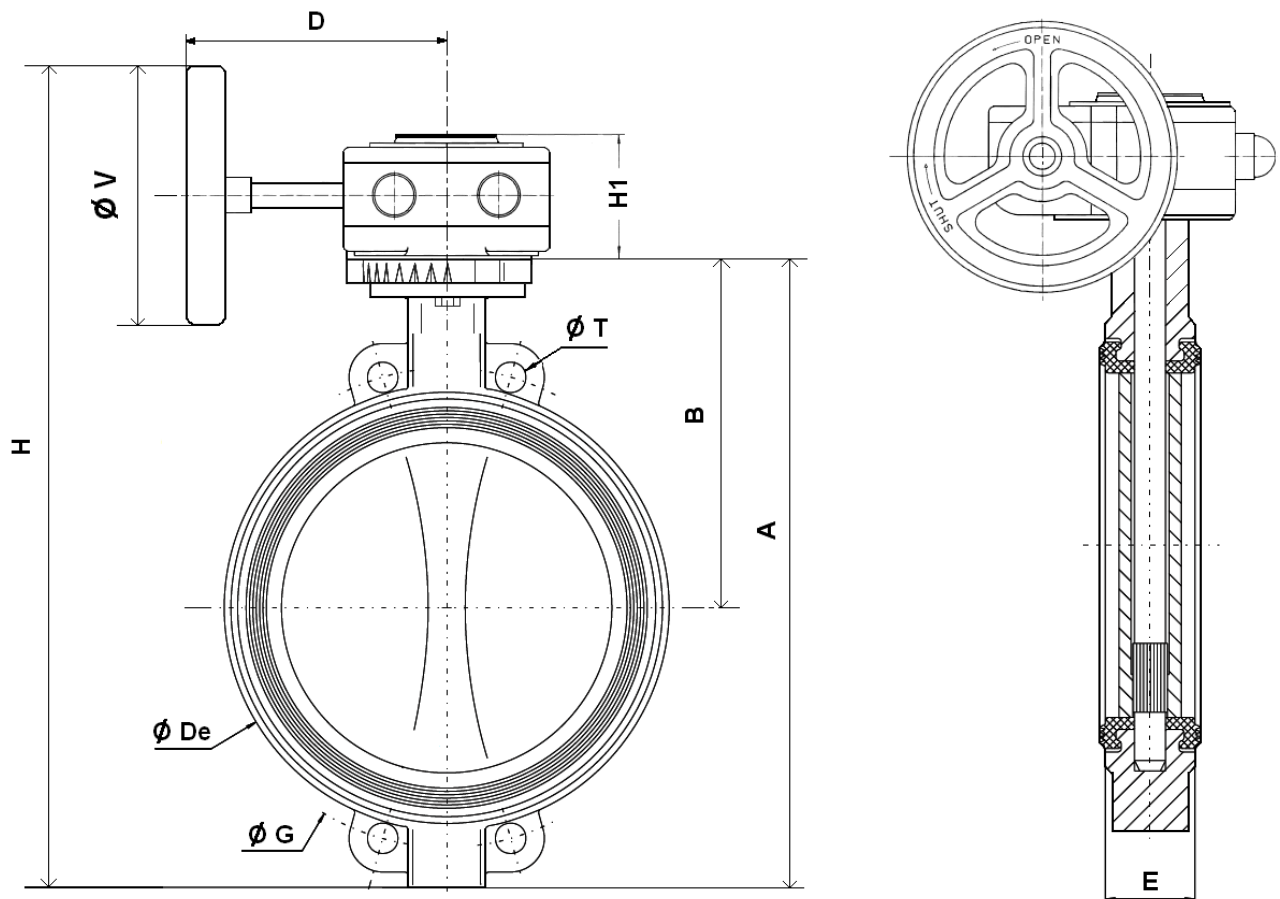

DN	450	500	600	700	750	800	900	1000	1100	1200	1300	1400
A	738	822	965	1100	1150	1248	1325	1457	1580	1720	1910	1990
B	394	440	507	575	600	655	685	754	815	873	1005	1025
Ø De	538	595	695	804	860	911	1010	1124	1225	1330	1460	1530
D	364	386	421	440	440	438	492	492	492	550	605	605
E	114	127	154	165	190	190	203	216	216	254	360	360
H	1083	1171	1376	1409	1459	1657	1688	1820	1943	2178	2260	2429
H1	90	98	122	117	117	117	125	125	125	115	178	178
Ø G	565	620	725	840	900	950	1050	1160	1270	1380	-	1590
Ø T	M24	M24	M27	M27	M30	M30	M30	M33	M33	M36	-	M39
Ø V	600	600	700	500	500	700	600	600	600	800	700	700
Weight (Kg)	105.8	143.8	215.3	307	345	381.3	579.8	735.8	914.8	1106.5	1882	2132

WAFER BUTTERFLY VALVE

SIZE ISO PN10 (in mm) :

- Valves with chain gear box :

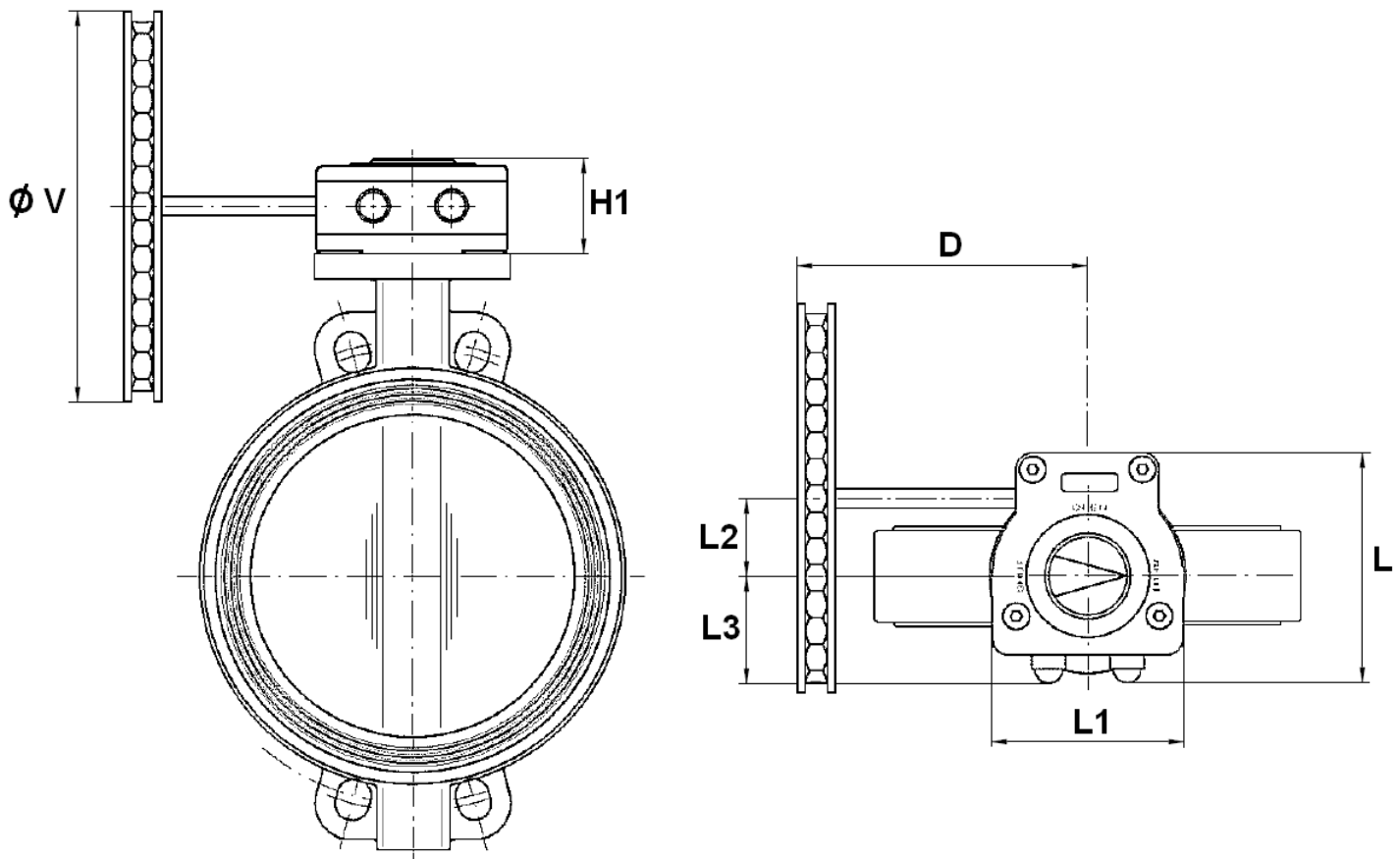

DN	32/40	50	65	80	100	125	150	200	250	300	350	400	450	500
D	120	120	120	120	120	126	126	126	214	214	331	331	350	365
H1	58	58	58	58	58	58	58	58	77	77	88	88	90	98
L	130	130	130	130	130	130	130	130	177.5	177.5	222	222	232	267
L1	100	100	100	100	100	100	100	100	146	146	175	175	204	227
L2	50	50	50	50	50	50	50	50	60	60	80	80	86	104.5
L3	58	58	58	58	58	58	58	58	82.5	82.5	85	85	100	110
Ø V	125	125	125	125	125	210	210	200	300	300	400	400	500	500
Weight (Kg)	4.81	6.01	6.75	6.95	8.35	10.35	11.95	17.45	31.5	39.8	53.3	66.3	113.2	150.7

WAFER BUTTERFLY VALVE

GEARBOX SPECIFICATIONS :

DN	32/50	65	80/100	125/150	200	250	300	350
Ref.	1197050	1197065	1197100	1197150	1197200	1197250	1197300	1197350
Ratio factor	37 : 1	37 : 1	37 : 1	37 : 1	37 : 1	36 : 1	36 : 1	50 : 1
Turns number for closing / opening	9.25	9.25	9.25	9.25	9.25	9	9	12.5
Input torque (Nm)	12.5	12.5	12.5	12.5	12.5	23	23	50
Output torque (Nm)	300	300	300	300	300	675	675	1310

DN	400	450	500	600	700	800	900	1000
Ref.	1197400	1197451	1197501	1197601	1197700	1197800	-	-
Ratio factor	50 : 1	38 : 1	55 : 1	52 : 1	208 : 1	208 : 1	312 : 1	312 : 1
Turns number for closing / opening	12.5	9.5	13.75	13	52	52	78	78
Input torque (Nm)	50	86	96	160	65	65	80	80
Output torque (Nm)	1310	1620	2640	4160	6800	6800	12500	12500

DN	1200	1300	1400
Ratio factor	702 : 1	720 : 1	720 : 1
Turns number for closing / opening	175.5	180	180
Input torque (Nm)	50	91	91
Output torque (Nm)	17000	32000	32000

WAFER BUTTERFLY VALVE

NECK AND DISC SIZE (in mm) :

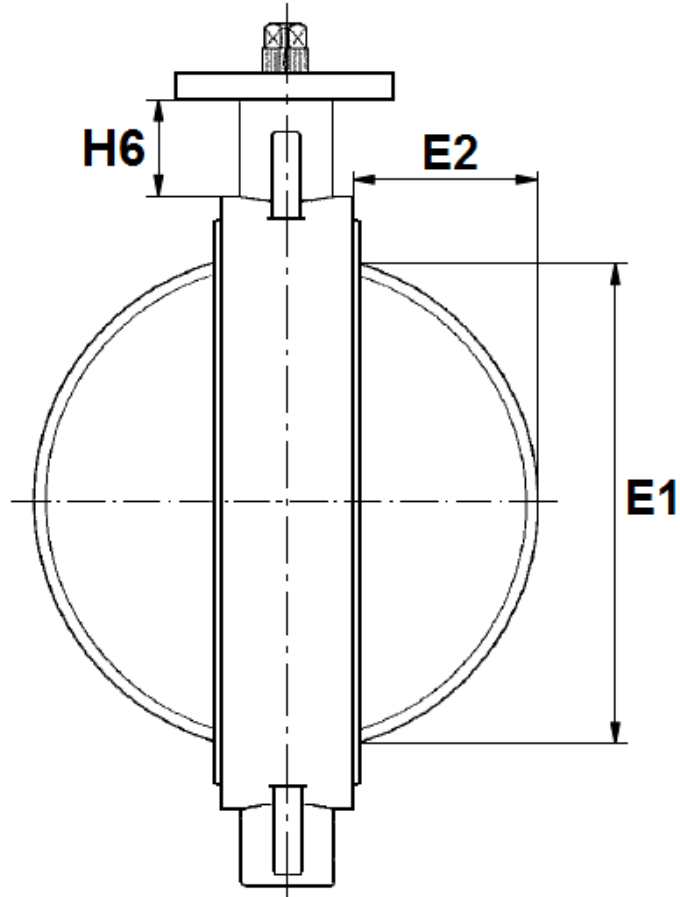

DN	32/40	50	65	80	100	125	150	200	250	300	350	400	450	500	600
E1	23	24.5	46	65	85	109	136	188	238	289	331	385	424	479	575
E2	3.5	3.5	9.5	17	24	33.5	45.5	69	90	110.5	131	148	162.5	184	221
H6	76	82	80	80	88	93	89	99	71	76	69	80	96	119	127

DN	700	750	800	900	1000	1100	1200	1300	1400
E1	680	721	777	850	957	1052	1146	1261	1368
E2	267.5	278	305	335.5	382.5	429	460	475.5	527.5
H6	148	140	170	150	162	175	176	240	228

WAFER BUTTERFLY VALVE

SIZE (in mm) :

- **Stem extension for isolation (75 mm) :**

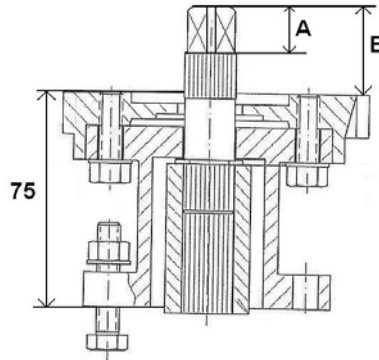

DN	32-50	65	80-100	125-150	200
A	19	19	19	17	17
B	34	34	34	34	34
Weight (Kg)	0.8	0.8	0.9	0.9	1

- **Square lever for special key (30x30 mm) :**

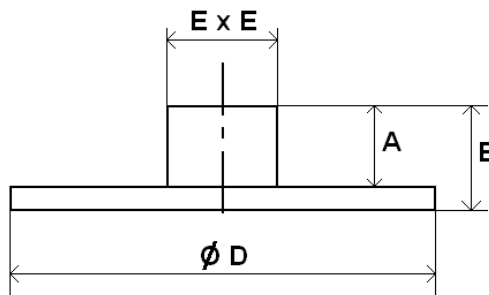

DN	32-50	65	80-100	125-150	200
A	20	20	20	20	20
B	31	31	32	32	32
Ø D	107	107	107	107	107
E x E	30 x 30	30 x 30	30 x 30	30 x 30	30 x 30
Weight (Kg)	0.88	0.88	0.88	0.88	0.88

WAFER BUTTERFLY VALVE

ISO MOUNTING PAD AND STEM SIZE (in mm) :

DN 32 – 400

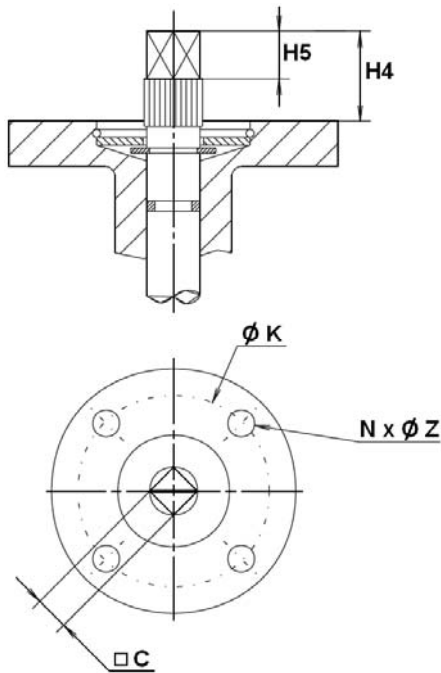

DN 450 - 1400

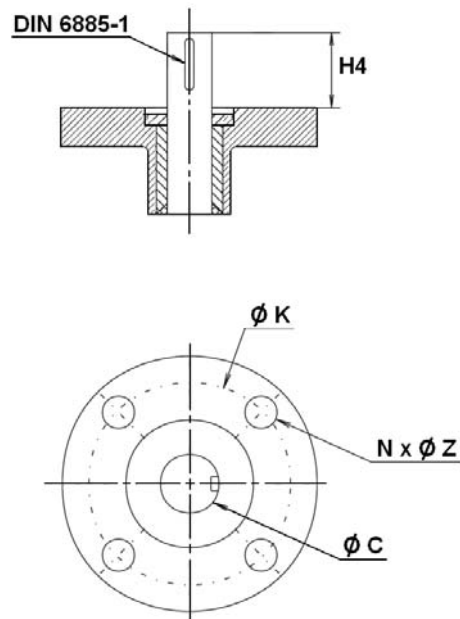

DN	32/40	50	65	80	100	125	150	200	250	300	350	400
H4	30	30	30	30	30	30	30	30	40	40	40	40
H5	17	17	17	17	17	17	17	17	20	20	20	20
C	8	8	9	11	11	14	14	17	19	22	22	27
Ø K	70	70	70	70	70	70	70	70	102	102	140	140
ISO	F07	F07	F07	F07	F07	F07	F07	F07	F10	F10	F14	F14
N x Ø Z	4 x 9	4 x 9	4 x 9	4 x 9	4 x 9	4 x 9	4 x 9	4 x 9	4 x 11	4 x 11	4 x 18	4 x 18

DN	450	500	600	700	750	800	900	1000	1100	1200	1300	1400
H4	80	80	90	90	110	110	110	110	110	110	120	120
Ø C	50	50	60	60	65	65	80	80	80	100	120	120
Ø K	140	140	165	254	254	254	254	254	254	254	298	298
ISO	F14	F14	F16	F25	F25	F25	F25	F25	F25	F25	F30	F30
N x Ø Z	4 x 18	4 x 18	4 x 22	8 x 18	8 x 18	8 x 18	8 x 18	8 x 18	8 x 18	8 x 18	8 x 22	8 x 22

WAFER BUTTERFLY VALVE

STANDARDS :

- Fabrication according to ISO 9001:2008
- Designing according to ISO 10631
- DIRECTIVE 97/23/CE : CE N° 0038
Risk Category III module H
- Tests according to ISO 5208, A class
- Between flanges according to EN 1092-1 PN10
- ISO 5211 mounting pad
- Length according to ISO 5752 short series 20, EN 558 series 20 (NF 29305), BS 5155 Wafer short/medium, DIN 3202 part 3, series K1
- ATEX Group II Category 2 G/2D Zone 1 & 21 Zone 2 & 22 (optional marking)
- French water agreement **A.C.S. N° 13 ACC LY 404** for types **1150** and **1153** from **DN32 to 1400**
- Approval certificate Russian **GOST-R**
- Approval certificate **Marine Lloyd's** N° 99/00131 from DN40 to 600
- Approval certificate **Marine ABS**, N° MD1935037 up to DN1400
- Approval certificate **Marine DNV**, N° P-13614
- Approval certificate **Marine BUREAU VERITAS**, N° 14087/B0 BV from DN32 to 1000
- OTAN agreement (N° 286B)

ADVICE : Our opinion and our advice are not guaranteed and SFERACO shall not be liable for the consequences of damages. The customer must check the right choice of the products with the real service conditions.

INSTALLATION INSTRUCTIONS

GENERAL GUIDELINES :

- Ensure that the valves to be used are appropriate for the conditions of the installation (type of fluid, pressure and temperature).
- Be sure to have enough valves to be able to isolate the sections of piping as well as the appropriate equipment for maintenance and repair.
- Ensure that the valves to be installed are of correct strength to be able to support the capacity of their usage.
- **Installation of all circuits should ensure that their function can be automatically tested on a regular basis (at least two times a year).**

WAFER BUTTERFLY VALVE

INSTALLATION INSTRUCTIONS :

- **Before installing the valves, clean and remove any objects from the pipes** (in particular bits of sealing and metal) which could obstruct and block the valves.
- **Ensure that both connecting pipes either side of the valve (upstream and downstream) are aligned** (if they're not, the valves may not work correctly).
- **Make sure that the two sections of the pipe (upstream and downstream) match, the valve unit will not absorb any gaps. Any distortions in the pipes may affect the tightness of the connection, the working of the valve and can even cause a rupture.** To be sure, place the kit in position to ensure the assembling will work.
- **If sections of piping do not have their final support in place, they should be temporarily fixed. This is to avoid unnecessary strain on the valve.**
- The valve must be inserted between flanges with disc half opened but the disc must not overpass the valve thickness. Position the bolts to keep centered the valve. Then open fully the valve and tighten the bolts. **See graph under.**

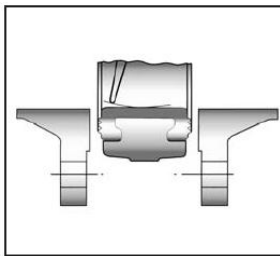

Half open valve introduction

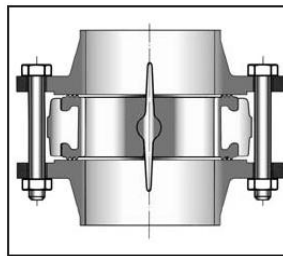

Complete opened disc valves
when screw tightening

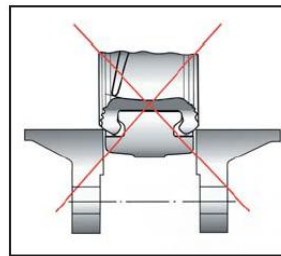

- Tighten the bolts in cross.
- The disc must move easily inside the pipe.
- Valves must be opened during cleaning operation.
- Tests must be done with a cleaned pipe.
- Tests must be done with opened valve. Test pressure must not be higher than the valve specification according to EN 12266-1.
- Then open slowly the valve.
- **Do not mount butterfly valves with stainless steel pressed collars and turning flanges without strias.**
- **And not on flat face flanges without strias (example : painted cast iron fittings)**

MAINTENANCE :

- We recommend to operate fully the valve 1 to 2 times per year.
- During maintenance operation, ensure that the pipe isn't under pressure, that there's no fluid in the pipe and that the valve is isolated. If there's a fluid in the pipe, evacuate it. Ensure that there are no risks due to the temperature or the fluid (like acids). If the fluid is corrosive, inert the installation before maintenance operation.