

→ Series 481



■ MATERIAL



■ SPECIFICATION



1/2" – 2"



- 10°C to + 95°C



Inlet pressure:
up to 30 bar
Outlet pressure:
0,5 to 15 bar
depending on version

■ SUITABLE FOR

Liquids	neutral and non-neutral	
Air, gases and vapours	neutral and non-neutral	
Warm water		

■ EXAMPLES OF USE

For the protection of:
- domestic water supply systems
- commercial and industrial plants
against too high supply pressure.
Pressure reducers are used, if within a piping system despite of varying pressures on the inlet side a certain pressure must not be exceeded on the outlet side.

- potable water supply according to DIN 1988
- process water supply in industrial- and building technology
- snow-making equipment
- fire-fighting equipment and sprinkler systems
- shipbuilding industry and offshore plants
- secondary areas in the food-, pharmaceutical- and cosmetics- industries.

■ APPROVALS

DIN-DVGW type examination	
Type approval ACS	
Type approval WRAS	
GOST-R	
Requirements DIN DVGW guidelines DIN EN 1567 DIN 1988 DIN EN ISO 3822 PED 97/23/EC	
Classification society Germanischer Lloyd Lloyd's Register EMEA American Bureau of Shipping Bureau Veritas	GL LR EMEA ABS BV

■ MATERIALS

Component	Material	DIN EN	ASME
Inlet body	Stainless steel	1.4408	CF8M
Outlet body	Stainless steel	1.4408	CF8M
Internal parts	Stainless steel	1.4408	CF8M
	Stainless steel	1.4404	316 L
Spring	Spring steel with anti-rust protection	1.1200	ASTM A228
Strainer	Stainless steel	1.4301	304

■ VALVE VERSION

m	with diaphragm	High-quality, heat-resistant moulded elastomere, fabric-reinforced diaphragm. Pressure adjustment by means of non-rising spindle. Valve insert with balanced single seat valve completely made of stainless steel.
----------	----------------	--

Complete valve insert SP/HP (order code: 481 Insert-DN..-seal) available as replacement part can be exchanged without removing the valve.

Complete valve insert LP (order code: 481 LP Insert-DN..-seal) available as replacement part can be exchanged without removing the valve.

Built-in dirt trap made of stainless steel.

Mesh size:	DN 15 to DN 32	0,60 mm
	DN 40 and DN 50	0,75 mm

■ MEDIUM

GF	gaseous and liquid	for water and distilled water, neutral and non-sticking liquids, compressed air and neutral gases; optionally with FPM elastomere seals for non-neutral media i.e. oils, fuels, oil-laden compressed air etc.
-----------	--------------------	---

■ TYPE OF LIFTING MECHANISM

0	without lifting device
----------	------------------------

■ OUTLET PRESSURE RANGES

SP	Standard version	Inlet pressure: up to 25 bar	Outlet pressure: from 1 to 8 bar (DVGW 6 bar)
HP	High-pressure version	Inlet pressure: up to 30 bar	Outlet pressure: from 5 to 15 bar
LP	Low-pressure version	Inlet pressure: up to 25 bar	Outlet pressure: from 0,5 to 2 bar

Fixed setting at a required outlet pressure against surcharge.

■ AVAILABLE NOMINAL DIAMETERS AND CONNECTION SIZES

Nominal diameter DN	15	20	25	32	40	50
Inlet threaded connection	1/2" (15)	3/4" (20)	1" (25)	1 1/4" (32)	1 1/2" (40)	2" (50)
Outlet threaded connection	1/2" (15)	3/4" (20)	1" (25)	1 1/4" (32)	1 1/2" (40)	2" (50)

■ TYPE OF CONNECTION INLET / OUTLET THREADED CONNECTIONS

BSP-Tm / BSP-Tm	Standard threaded connections	Male thread BSP-T / Male thread BSP-T	DIN EN 10226, ISO 7-1 / DIN EN 10226, ISO 7-1
------------------------	-------------------------------	---------------------------------------	---

■ SEALS

EPDM	Ethylene propylene diene	Elastomere moulded diaphragm and seals approvals according to drinking water directive	-10°C to +95°C
-------------	--------------------------	--	----------------

Against surcharge

FKM	Fluorocarbon	Elastomere moulded diaphragm and seals	-10°C to +95°C
------------	--------------	--	----------------

■ OPTIONS

Against surcharge

Pressure gauges 36, 39 or 40	Chapter Accessories
------------------------------	---------------------

Pressure gauges 41, 42 or 43 made of stainless steel	Chapter Accessories
--	---------------------

■ NOMINAL DIAMETERS, CONNECTIONS, INSTALLATION DIMENSIONS

Series 481: Connection, installation dimensions, ranges of adjustment							
Connection	DN	15	20	25	32	40	50
Inlet DIN EN 10226	G	1/2"	3/4"	1"	1 1/4"	1 1/2"	2"
Outlet DIN EN 10226	G	1/2"	3/4"	1"	1 1/4"	1 1/2"	2"
Inlet pressure SP, LP up to	bar	25	25	25	25	25	25
Inlet pressure HP up to	bar	30	30	30	30	30	30
Outlet pressure	bar	0,5 - 2	0,5 - 2	0,5 - 2	0,5 - 2	0,5 - 2	0,5 - 2
		1 - 8	1 - 8	1 - 8	1 - 8	1 - 8	1 - 8
		5 - 15	5 - 15	5 - 15	5 - 15	5 - 15	5 - 15
Installation dimensions in mm	L	142	158	180	193	226	252
	I	80	90	100	105	130	140
Weight	H (H1)	102 (128 ¹)	102 (128 ¹)	130 (150 ¹)	130 (150 ¹)	165 (185 ¹)	165 (185 ¹)
	h	33	33	45	45	70	70
Weight	kg	1,2 (1,5 ¹)	1,3 (1,6 ¹)	2,3 (2,8 ¹)	2,5 (3,0 ¹)	5,2 (5,9 ¹)	5,7 (6,4 ¹)
Kv value	m ³ /h	2,5 - 3,3	3,6 - 4,5	6,2 - 7,8	8,7 - 9,6	12 - 14	14,5 - 19
Max. capacity (water)	m ³ /h	7	9	16	18	30	35

¹for type 481mGFO-LP

■ MAIN DIMENSIONS, INSTALLATION DIMENSIONS

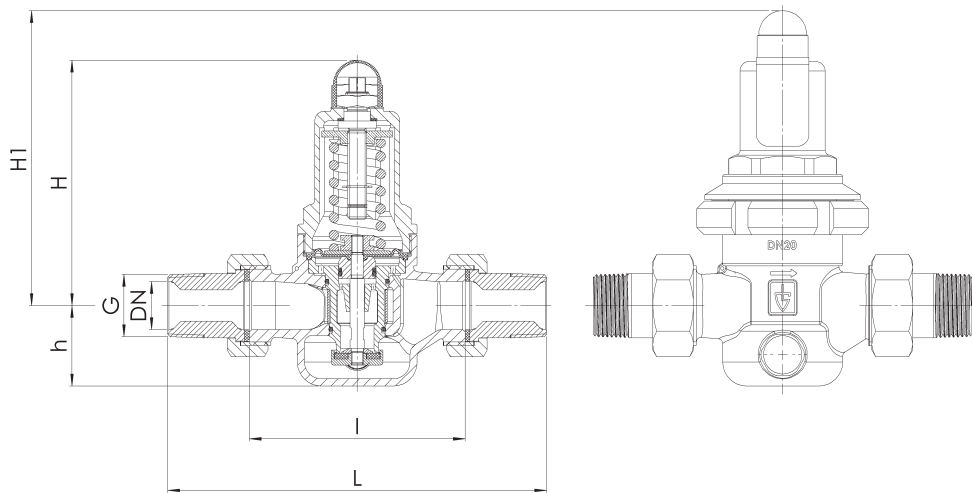

■ INDIVIDUAL SELECTION / VALVE CONFIGURATION

Series	Valve version	Medium	Lifting device	Outlet pressure	Nominal diameter DN	Connection type		Connection size		Seal	Options	Optional: fixed setting	Quantity
						Inlet	Outlet	Inlet	Outlet				
481	m	GF	0	SP	25	BSP-T m	BSP-T m	25	25	EPDM	Pressure Gauge 41		5
481	m	GF	0	LP	40	BSP-T m	BSP-T m	40	40	FKM		1,5	2
481	m	GF	0			BSP-T m	BSP-T m						
481	m	GF	0			BSP-T m	BSP-T m						

In this table you can configure a valve according to your individual requirements (similar to the *example* shown, which should be deleted before you enter your own data). Please complete the table by hand using the abbreviations in this datasheet and then fax it to: +49(0)7141.4889488
Please do not forget to add your personal data so that our sales team can contact you.

Name _____

First Name _____

Company _____

Telephone _____

E-Mail _____

Series 481:

Dimensioning by pressure loss on the outlet pressure side

Flow chart water

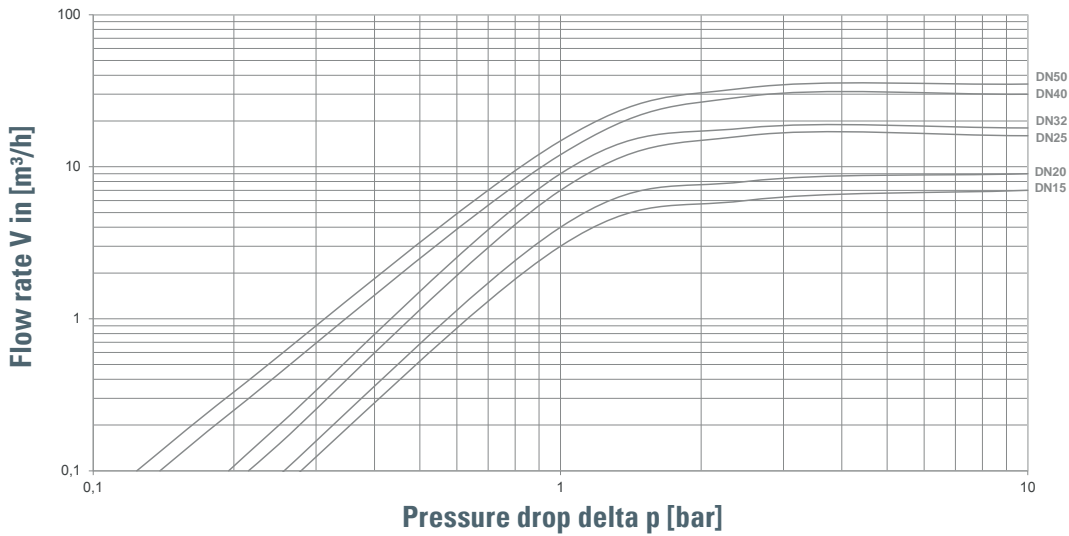

Dimensioning by flow velocity

For Liquids:

With help of the chart you can determine the nominal diameter (DN) for a given flow volume V (m³/h). According to DVGW-guidelines (DIN 1988) a flow velocity of 2 m/s in domestic water supply systems should not be exceeded.

For compressed air and other gaseous media:

The usual flow velocity for compressed air is 10 - 20 m/s. For gaseous media the flow volume V should always be shown in actual cubic meters/hour. If the flow volume is given in standard cubic meters, these should be converted into actual cubic meters before using the diagram.

$$V \text{ (m}^3\text{/h)} = \frac{V_{\text{Norm}} \text{ (Nm}^3\text{/h)}}{p_{\text{absolut}} \text{ (bar)}} = \frac{V_{\text{Norm}}}{p_0 + 1}$$

Actual cubic meters are based on the prevailing pressure of the medium on the outlet side of the pressure reducer.

