

352bHL

Safety valves made of spheroidal graphite cast iron, angle-type with flange connections

→ **Series 352bHL**



■ SUITABLE FOR

Hot water 

■ EXAMPLES OF USE

For the protection of:
 - thermostatically protected closed-circuit water heating systems with flow temperatures of up to 120°C for all static heights or rated output above 350 kW according to TRD 721, DIN 4751 and DIN EN 12828.

Should the thermostatic limiting and control unit fail, the safety valve has to blow-off the total heating output of the boiler as hot water and steam.

As these valves are completely made of metal, they can also be installed at high environmental or radiation temperatures.

- heating systems for building technology and industrial applications
- co-generation plants (CHP)
- biogas plants
- district heating transfer stations, building sub-stations

Safety valves are set and sealed at the factory.

■ APPROVALS

TÜV Type test approval 2007	D/G/H
EC type examination	D/G/H
GOST-R	D/G/H

Requirements

TRD 721
 AGFW 505
 DIN 4751 Part 2
 DIN EN 12828
 DIN EN ISO 4126-1
 PED 97/23/EC

Classification society

Germanischer Lloyd	GL
Lloyd's Register EMEA	LR EMEA
American Bureau of Shipping	ABS
Det Norske Veritas	DNV
Bureau Veritas	BV



■ MATERIAL



■ SPECIFICATION



DN 40 and DN 50 – 10°C to + 120°C 0,5 – 16 bar

■ MATERIALS

Component	Material	DIN EN	ASME
Inlet body	Spheroidal graphite cast iron	0.7043	Gr. 60-40-18
Outlet body	Spheroidal graphite cast iron	0.7043	Gr. 60-40-18
Internal parts	Stainless steel	1.4404	316 L
Spring	Stainless steel	1.4310	302
Bellows	Elastomere	EPDM	

■ VALVE VERSION

b	with bellows	for neutral and non-neutral media. Spring, moving parts and the environment are protected from being affected by the medium.
----------	--------------	---

■ MEDIUM

H	Hot water	Flow temperature ≤ 120°C in water heating systems
----------	-----------	---

■ TYPE OF LIFTING MECHANISM

L	Standard with lifting lever
----------	-----------------------------

■ AVAILABLE NOMINAL DIAMETERS AND CONNECTION SIZES

Nominal diameter DN		40	50
Inlet		40	50
Outlet	65	■	
	80		■

■ TYPE OF CONNECTION INLET / OUTLET FLANGE CONNECTIONS

FL / FL	Standard	Flange connection / flange connection	DIN EN 1092 / DIN EN 1092
----------------	----------	---------------------------------------	---------------------------

■ SEALS

EPDM	Ethylene propylene diene	Elastomere moulded seal with metallic support	-10°C to +120°C
-------------	--------------------------	---	-----------------

■ OPTIONS

Special versions on request.

Against surcharge

Connection for condensate pipe G 1/4" with sealing plug	Order description: AKL
---	-------------------------------

■ NOMINAL DIAMETERS, CONNECTIONS, INSTALLATION DIMENSIONS

Series 352bHL: Connection, installation dimensions, ranges of adjustment			
Nominal diameter	DN	40	50
Connection DIN EN 1092	DN / PN	40 / 40	50 / 40
Outlet DIN EN 1092	DN / PN	65 / 16	80 / 16
Installation dimensions in mm	L	115	120
	Lmax.	150	150
	H	345	345
	h	140	150
	D	150	165
	D1	185	200
	K / nxd	110 / 4x18	125 / 4x18
	K1 / n1xd1	145 / 4x18	160 / 8x18
	do	37	46
Weight	kg	17	19
Range of adjustment	bar	0,5-16	0,5-16

■ MAIN DIMENSIONS, INSTALLATION DIMENSIONS

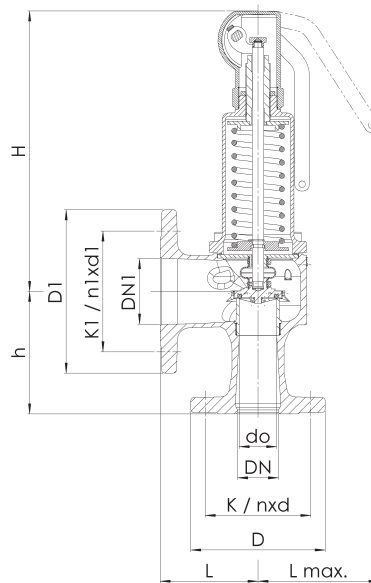

■ INDIVIDUAL SELECTION / VALVE CONFIGURATION

Series	Valve version	Medium	Lifting device	Nominal diameter DN	Connection type		Connection size		Seal	Options	Set pressure	Quantity
					Inlet	Outlet	Inlet	Outlet				
352	b	H	L	40	FL	FL	40	65	EPDM		4,5	3
352	b	H	L	50	FL	FL	50	80	EPDM	AKL	3,5	1
352	b	H	L		FL	FL			EPDM			
352	b	H	L		FL	FL			EPDM			

In this table you can configure a valve according to your individual requirements (similar to the *example* shown, which should be deleted before you enter your own data). Please complete the table by hand using the abbreviations in this datasheet and then fax it to: +49(0)7141.4889488
Please do not forget to add your personal data so that our sales team can contact you.

Name _____

First Name _____

Company _____

Telephone _____

E-Mail _____

■ CAPACITY TABLE

Series 352bHL: Blowing-off rates at 10% above set pressure						
Nominal diameter DN		40			50	
Set pressure bar		I	II	I	II	
Heating I	0,5	320	503	480	750	
	1	490	785	740	1176	
kW	1,5	640	1032	960	1547	
	2	780	1273	1190	1939	
Steam II	2,5	920	1510	1400	2294	
	3	1040	1726	1600	2661	
kg/h	3,5	1160	1937	1790	2985	
	4	1280	2151	1980	3315	
	4,5	1400	2364	2160	3643	
	5	1510	2575	2330	3970	
	5,5	1630	2789	2520	4299	
	6	1750	3003	2690	4629	
	6,5	1860	3212	2860	4951	
	7	1970	3420	3040	5272	
	7,5	2080	3632	3210	5598	
	8	2190	3843	3380	5923	
	8,5	2300	4053	3540	6247	
	9	2410	4263	3710	6570	
	9,5	2520	4472	3880	6893	
	10	2620	4681	4040	7215	
	11	2840	5097	4380	7856	
	12	3050	5511	4700	8494	
	13	3260	5928	5030	9138	
	14	3470	6348	5340	9784	
	15	3670	6763	5660	10425	
	16	3880	7181	5980	11069	

In order to achieve the highest possible heating output, up to three valves per system can be installed.

To protect indirectly heated heat generators in accordance with DIN 4751 Part 2 the safety valves have to be rated for the flow rate of the expansion water.
For the valid blow-off capacities in m³/h water see capacity chart **352 on datasheet 3.10**