

→ Series 452



■ SUITABLE FOR

Liquids	neutral and non-neutral	
Air, gases and vapours	neutral and non-neutral	
Steam		

■ EXAMPLES OF USE

For the protection of:

- pressure tanks and -systems for neutral / non-neutral vapours, gases and liquids
 - steam boilers and steam plants
 - bulk transport vehicles for liquid, granular and dusty goods¹
- Please observe plant-specific regulations and use of appropriate valve version and sealing material.

- chemical plants
- biogas plants
- industrial- and commercial boiler plants
- shipbuilding industry and marine equipment
- secondary areas in the food-, beverage-, pharmaceutical- and cosmetics-industries

Safety valves are set and sealed at the factory.

■ APPROVALS

TÜV-Type test approval 2007	D/G, F, F/K/S ¹
EC type examination	S/G, L, F/K/S ¹
GOST-R	D/G (S/G), F (L), F/K/S ¹

Requirements

AD 2000 Data sheet A2
TRD 421
TRB 801 No. 22 and No. 23¹
DIN EN ISO 4126-1
PED 97/23/EC

Classification society

Germanischer Lloyd	GL
Lloyd's Register EMEA	LR EMEA
American Bureau of Shipping	ABS
Det Norske Veritas	DNV
Bureau Veritas	BV



■ MATERIAL



■ SPECIFICATION



DN 40 and DN 50 - 60°C to + 400°C 0,5 – 25 bar
depending on version

■ MATERIALS

Component	Material	DIN EN	ASME
Inlet body	Stainless steel	1.4408	CF8M
Outlet body	Stainless steel	1.4408	CF8M
Internal parts	Stainless steel	1.4404	316 L
Spring	Stainless steel	1.4310	302
Bellows (optional)	Stainless steel	1.4571	316 Ti

¹only for versions with bellows

■ VALVE VERSION

s	non-gastight version of spring housing	for neutral media without counter pressure.
b	with bellows	for neutral and non-neutral media and/or counter pressure up to 4 bar. Spring, moving parts and the environment are protected from being affected by the medium.
t	gastight version of spring housing	for neutral and non-neutral media without counter pressure. The environment is protected from being affected by the medium.
tb	gastight version with bellows	for neutral and non-neutral an particularly for flammable, toxic and environmentally hazardous media and/or counter pressure up to 4 bar. Spring, moving parts and the environment are protected from being affected by the medium. Double gastight.

■ MEDIUM

G	gaseous	Air, vapours, gases and - depending on safety valve version and seal - also for steam
F	liquid	The temperature of the medium under atmospheric pressure must not reach boiling point
GF	gaseous and liquid	Air, vapours, gases, steam and liquids

■ TYPE OF LIFTING MECHANISM

L	Standard with lifting lever
O	without lifting device

■ AVAILABLE NOMINAL DIAMETERS AND CONNECTION SIZES

Nominal diameter DN		40	50
Inlet		40	50
Outlet	65	■	
	80		■

■ CONNECTION TYPE INLET / OUTLET FLANGE CONNECTIONS

FL / FL	Standard	Flange connection / flange connection	DIN EN 1092 / DIN EN 1092
----------------	----------	---------------------------------------	---------------------------

■ SEALS

NBR	Nitrile rubber	Elastomere moulded seal with metallic support	-30°C to +130°C
EPDM	Ethylene propylene diene	Elastomere moulded seal with metallic support	-40°C to +170°C
FKM	Fluorocarbon	Elastomere moulded seal with metallic support	-20°C to +200°C
PTFE	Polytetrafluoroethylene	Flat seal	-60°C to +225°C
Against surcharge			
FFKM	Perfluorinated rubber	Elastomere moulded seal with metallic support	-10°C to +260°C
MD	Metal-to-metal sealing	Flat seal	-60°C to +400°C

■ OPTIONS

Special versions on request.

Against surcharge

Connection for condensate pipe G 1/4" with sealing plug Order description: **AKL**

■ NOMINAL DIAMETERS, CONNECTIONS, INSTALLATION DIMENSIONS

Series 452: Connection, installation dimensions, ranges of adjustment			
Nominal diameter	DN	40	50
Connection DIN EN 1092	DN / PN	40 / 40	50 / 40
Outlet DIN EN 1092	DN / PN	65 / 16	80 / 16
Installation dimensions in mm	L	115	120
	Lmax	150	150
	H / H ¹	345 / 362	345 / 362
	h	140	150
	D	150	165
	D1	185	200
	K / nxd	110 / 4x18	125 / 4x18
	K1 / n1xd1	145 / 4x18	160 / 8x18
	do	37	46
Weight	kg / kg ¹	17 / 18	19 / 20
Range of adjustment	bar	0,5-25	0,5-25

¹Details for the version with bellows

■ MAIN DIMENSIONS, INSTALLATION DIMENSIONS

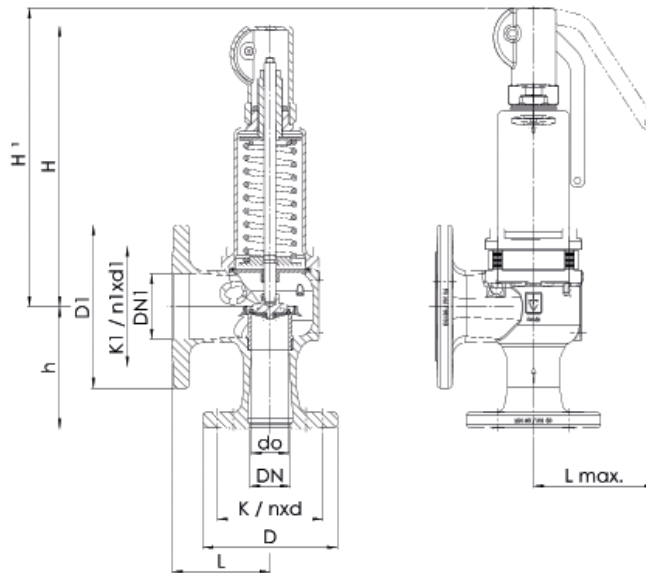

■ INDIVIDUAL SELECTION / VALVE CONFIGURATION

Series	Valve version	Medium	Lifting device	Nominal diameter DN	Connection type		Connection size		Seal	Options	Set pressure	Quantity
					Inlet	Outlet	Inlet	Outlet				
452	<i>b</i>	<i>G</i>	<i>L</i>	<i>50</i>	FL	FL	<i>50</i>	<i>80</i>	<i>EPDM</i>		<i>5,0</i>	<i>2</i>
452					FL	FL						
452					FL	FL						
452					FL	FL						

In this table you can configure a valve according to your individual requirements (similar to the *example* shown, which should be deleted before you enter your own data). Please complete the table by hand using the abbreviations in this datasheet and then fax it to: +49(0)7141.4889488
Please do not forget to add your personal data so that our sales team can contact you.

Name _____

First Name _____

Company _____

Telephone _____

E-Mail _____

■ CAPACITY TABLE

Series 452: Blowing-off rates at approx. 10% above set pressure								
Nominal diameter DN		40			50			
Set pressure bar		I	II	III	I	II	III	III
Air I	0,5	667	503	23	995	750	36	
	1	983	785	32	1472	1176	49	
	1,5	1299	1032	39	1948	1547	60	
Steam II	2	1615	1273	45	2461	1939	69	
	2,5	1926	1510	50	2926	2294	77	
	3	2208	1726	55	3404	2661	85	
Water III	3,5	2491	1937	59	3839	2985	91	
	4	2773	2151	63	4275	3315	98	
	4,5	3056	2364	67	4710	3643	104	
	5	3338	2575	71	5146	3970	109	
	5,5	3621	2789	74	5581	4299	114	
	6	3903	3003	77	6016	4629	120	
	6,5	4186	3212	81	6452	4951	124	
	7	4468	3420	84	6887	5272	129	
	7,5	4751	3632	86	7323	5598	134	
	8	5033	3843	89	7758	5923	138	
	8,5	5316	4053	92	8194	6247	142	
	9	5598	4263	95	8629	6570	146	
	9,5	5881	4472	97	9064	6893	150	
	10	6163	4681	100	9500	7215	154	
	11	6728	5097	105	10371	7856	162	
	12	7293	5511	109	11241	8494	169	
	13	7858	5928	114	12112	9138	176	
	14	8423	6348	118	12983	9784	183	
	15	8988	6763	122	13854	10425	189	
	16	9553	7181	126	14725	11069	195	
17	10118	7586	130	15595	11693	201		
18	10683	8002	134	16466	12334	207		
19	11248	8416	138	17337	12973	213		
20	11813	8835	141	18208	13617	218		
21	12378	9253	145	19079	14261	224		
22	12943	9670	148	19949	14905	229		
23	13508	10087	151	20820	15547	234		
24	14073	10503	155	21691	16190	239		
25	14638	10920	158	22562	16831	244		

At temperatures above 220°C the yield strength decrease of the nominal pressure rating must be taken into account.