

Immersion Pumps (S)TH17

50 Hz

Closed impellers

STH1702...1717

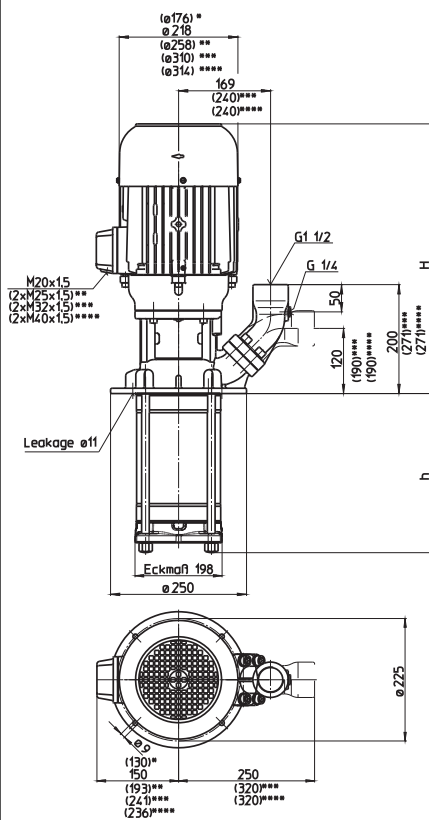

TH1702...1717

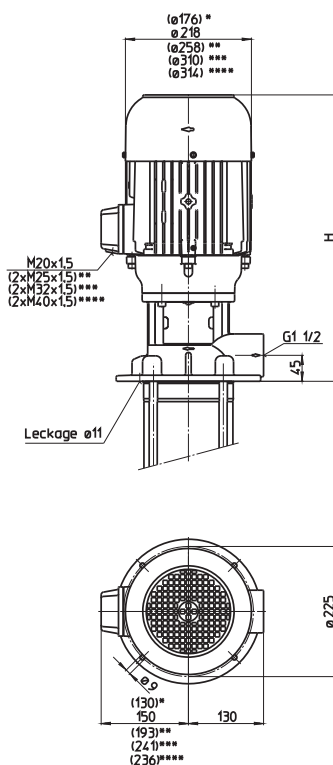

- *) Dimension for (S)TH1702
- **) Dimension for (S)TH1706...1708
- ***) Dimension for (S)TH1709...1712
- ****) Dimension for (S)TH1713...1717

Type	Vol. del. at manom. del. head l/min / m	Height H mm	Depth of immersion h mm	Weight kg	Power kW	Voltage 3~ V	Fre- quen- cy Hz	Current A	Speed 1/min
(S)TH1702A180	300/24	492	182	42	2.2	220-240 380-415	50 50	7.8 4.5	2890 2890
(S)TH1703A280	300/37	531	278	55	3.3	220-240 380-415	50 50	11.6 6.7	2930 2930
(S)TH1704A280	300/51	561	278	61	5.0	220-240 380-415	50 50	17.3 10.0	2920 2920
(S)TH1705A380	300/66	561	374	64	5.5	220-240 380-415	50 50	18.9 10.9	2915 2915
(S)TH1706A380	300/77	640	374	87	7.5	380-415	50	14.3	2950
(S)TH1707A470	300/90		470	97					
(S)TH1708A470	300/103	640	470	116	9.0	380-415	50	16.7	2955
(S)TH1709A570	300/116	647	566	124	11.0	380-415	50	20.1	2960
(S)TH1710A570	300/130			126					
(S)TH1711A660	300/143	647	662	128	13.0	380-415	50	24.2	2960
(S)TH1712A660	300/157			129					
(S)TH1713A760	300/172	952	758	150	15.0	400	50	27	2960
(S)TH1714A760	300/186	1002	758	168	18.5	400	50	32	2955
(S)TH1715A900	300/200		902	170					
(S)TH1716A900	300/212			172					
(S)TH1717A900	300/227			175					

Immersion Pumps

series TH and FH use **closed impellers** in order to minimize power consumption and to optimize hydraulic pump efficiencies.

In addition, the TH series offers high pressures at short immersion depths. Inline pumps of the series FH can be used as **boosting pumps** if provided with positive inlet pressure. This inlet pressure can be provided by the central coolant supply or a feed pump. In such a setup, pumps of the series FH can raise the incoming pressure by up to 26 bar.

Extended length is possible. See medium pressure pumps features within the technical information section.

Applications

Types of fluid
 Industry water
 coolants
 cooling/cutting oils
 Kinematic viscosity
 ...25 mm²/s (25 cSt)
 Pumping temperature
 0...80° C

Construction

Pump body	cast iron
Cover	cast iron
Impellers	CrNi-steel
Shaft	CrNi-steel
Diffusers	CrNi-steel
Mechanical seal	SiC
O-rings	Viton
Optional:	
Pump body	CrNi-steel
Cover	CrNi-steel

Noise level	
(S)TH1702	63 dBA
(S)TH1703...(S)TH1705	71 dBA
(S)TH1706...(S)TH1712	74 dBA
(S)TH1713...(S)TH1717	78 dBA

