

Horizontal End-Suction Pumps

SBA401S...403S

Axial/semi-open impellers



60 Hz

SBA401S...403S

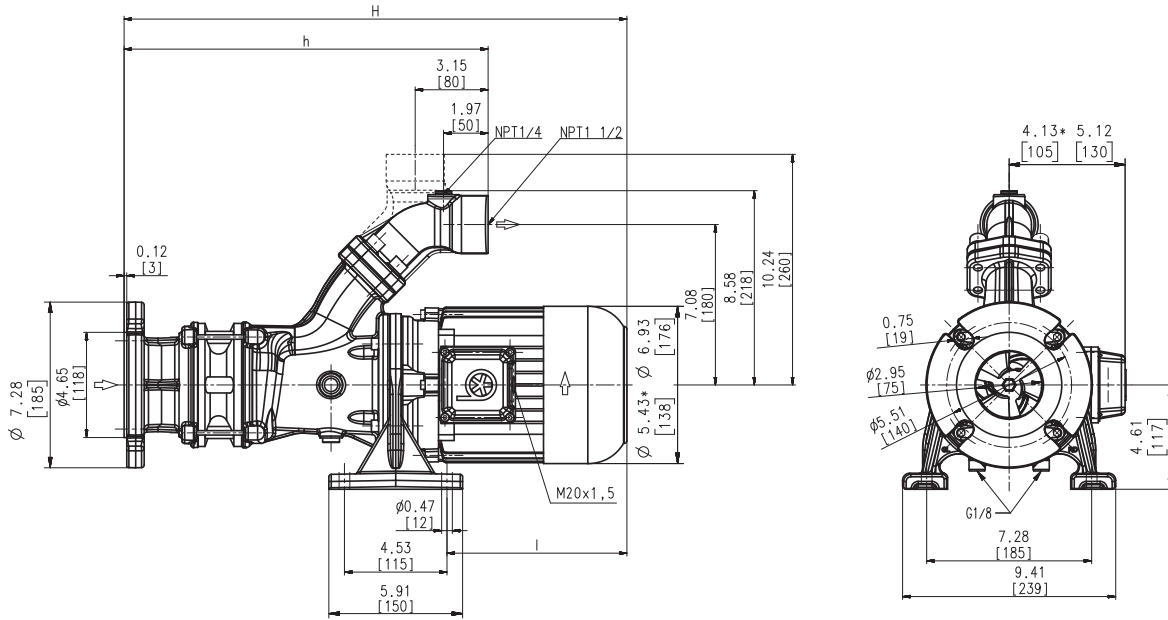

Dimensions in Inches / mm
*) Dimensions SBA401S

| Type | Flow at head | Dimensions | | | | Length | | Weight | | Power HP kW | Voltage 3~ V | Fre- quen- cy Hz | Current AMPS | Speed RPM |
|----------------|-----------------------|------------|------|--------|------|--------|------|--------|----|-------------------|--------------------|---------------------------|-----------------|--------------|
| | GPM /Feet l/min /m | H inch | H mm | h inch | h mm | l Inch | l mm | Lbs | kg | | | | | |
| SBA401S | 60/25 | 19.6 | 497 | 14.2 | 360 | 7.2 | 184 | 68.4 | 31 | 1.4 | 230 | 60 | 4.2 | 3440 |
| | 240/7 | | | | | | | | | 1.06 | 460 | 60 | 2.1 | 3440 |
| SBA402S | 60/47 | 23.3 | 592 | 16.1 | 409 | 9.1 | 230 | 86.0 | 39 | 2.3 | 230 | 60 | 6.2 | 3470 |
| | 240/14 | | | | | | | | | 1.75 | 460 | 60 | 3.1 | 3470 |
| SBA403S | 60/70 | 27.6 | 700 | 18.0 | 458 | 11.4 | 289 | 103.6 | 47 | 3.4 | 230 | 60 | 8.8 | 3480 |
| | 240/21 | | | | | | | | | 2.55 | 460 | 60 | 4.4 | 3480 |



Horizontal End-Suction Pumps

are centrifugal inline pumps with a compact design where the impeller is mounted onto the extended motor shaft. These pumps are not self-priming and must be gravity fed. All pumps are equipped with a single mechanical seal. Upon request a second mechanical seal is available to allow for dry-running (-GD). This pump series is designed for horizontal installations next to a tank and for pumping **air entrained coolant** fluids, such as **water-soluble coolants or cutting oils**, as they occur in **high speed turning, milling or grinding applications**. The SBA pumps are equipped with the user-friendly **SAE flange** connection which allows for either vertical or horizontal pipe connection and the connection of a pressure gauge with NPT 1/4. For more information see mechanical features within the technical information section.

Applications

Types of fluid
 coolants
 cooling/cutting oils
 Kinematic viscosity
 ...200 SSU (...45 mm²/s)
 Pumping temperature
 30...175 °F (0...80 °C)

Construction

| | |
|--|------------|
| Pump body | cast iron |
| Cover | cast iron |
| Impeller axial | cast steel |
| Impeller radial | cast steel |
| Shaft | steel |
| Mechanical seal | SiC |
| Noise level (Motor only; Tolerance +3 dBA) | |
| SBA401S | 62 dBA |
| SBA402S...SBA403S | 69 dBA |

