

UTN-L / UTN-BL I° frame



UTN-BL PFA
CLOSE COUPLED EXECUTION

Plastic and Fluoroplastic Lined Magnetic drive Horizontal - Single Stage - Process Centrifugal pumps

Lining: PP (Polypropylene), PVDF (Polyvinylidene fluoride), PFA (Perfluoroalkoxy)

Close-coupled and Long-coupled executions



Comply to :
2006/42/CE

Design to :
ISO 2858 / EN 22858
(ex DIN 24256)

ISO 5199 - UNI 15783

ATEX 100
Directive 94/9/EC



Flanged
UNI 1092-2 (ISO 7005-2)
PN16RF type B
slotted ANSI 150RF



UTN SERIES

Mag drive concept

The synchronous drive configuration is based on an outer magnet ring assembly built to magnetically couple with an inner magnet ring assembly.

These two magnet rings are locked together by the flux of attracting magnet poles flowing through the containment isolation shell.



UTN-L

Long Coupled pumps use the back pull-out principle and a strong bearing housing with flexible coupling.



UTN-BL

Close coupled pumps are equipped with standard motors.

Versatility

Suitable for handling corrosive, aggressive and hazardous liquids (low viscosity, clean or slightly contaminated) in the chemical, petrochemical and Pharma industries, where the need of high safety standards is the first requirement.

Reliability

The pump is equipped with reliable grease lubricated bearing bracket, especially developed to be suitable even under heavy duty service.

Design

UTN range share the same hydraulic design with the UCL series (mechanical seal pumps) which have been developed focusing on chemical Industry's requests.

Application Fields

Petrochemical Processing



Fertilizer Processing



Basic Chemical Processing



Air Treatment



Fine Chemical Processing



Detergents Processing



Fibre Processing

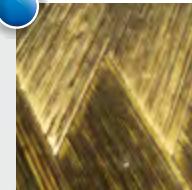

Active Pharmaceutical Ingredients



3D VIEW

Inner and Outer magnets are equipped with NdFeB (neodymium iron boron) and SmCo (samarium cobalt) permanent magnets. Patented cage magnet attachment guarantee stability during the operation of the pump.

All PFA components are made through **Transfer Moulding** process. The Transfer Moulding process is also employed for PVDF \ PP lined casing.

Sealless design

Total containment, essential for hazardous, aggressive or valuable product.

All wetted parts have a high chemical resistance employing a performing material as Virgin unfilled PFA, granting also a **wall thickness of at least 4mm to 5mm Virgin PFA**.
Alternative available materials for the **Wetted parts: PP and PVDF**.

The pump design grants a **modular configuration** of either end-suction or close-coupled design.

Vacuum resistant housing lining. Moreover, all PFA components are made through transfer moulding process.

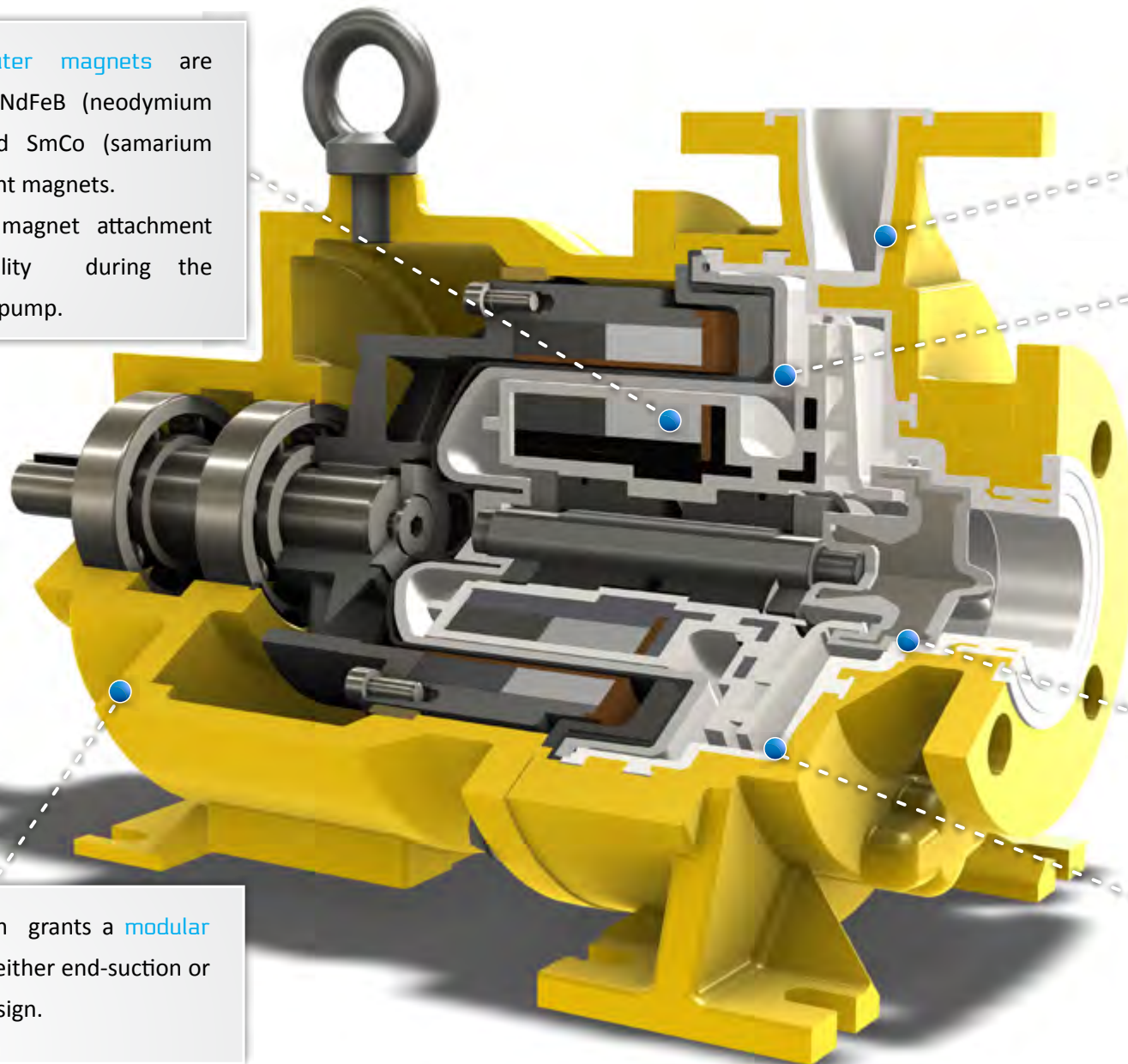

FEATURES



CASING

- The ductile cast iron armour protects the fluoroplastic peripheral surfaces of the pump from pipe strain, vibration, external shocks and during the handling; moreover it allows the casing to be Vacuum resistant.
- Top centerline discharge for air handling, self-venting.
- Drained casing (optional).

IMPELLER ASSEMBLY



- The closed impeller design, made around a sturdy metallic core surrounded by a minimum 4mm of fluoroplastic material, provides maximum efficiency and reliability.
- Standard back vanes reduce axial thrust and seal chamber pressure to guarantee extraordinary bearing and seal life.
- The integral design of the impeller and inner magnet prevents any misalignment problem, reducing also the production cost.

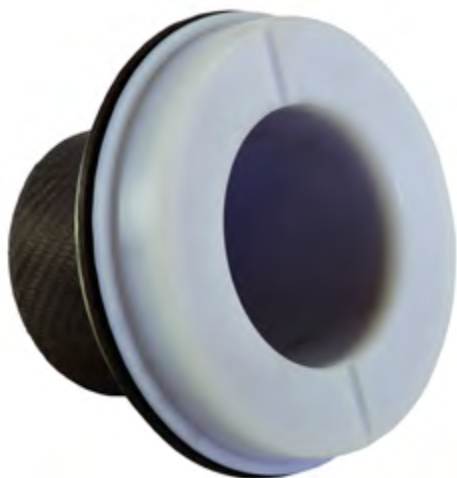

ISOLATION SHELL

- Virgin unfilled PFA double Isolation Shell configuration : Virgin PFA on wet side externally reinforced by Carbon Fibre reinforcement.
- PP and PVDF: more than 4mm of thickness.
- Zero Eddy Current Losses thanks to non-metallic execution.

SHAFT



- Axial and radial loads are well distributed thanks to the highly reliable rotating parts design. The static shaft (SiC, Ceramic or RunSafeSiC) is supported in the can and by the lining suction cover.
- Its small diameter and the absence of bending forces, allow the shaft to be a reliable support for the impeller assembly : moreover, this execution limits the circumferential speed of plain bearings, as well as their heating or wear.

ROTATING BUSHINGS AND AXIAL THRUST



Large Silicon Carbide (Carbon or Ceramic) Rotating Bushings and Static Axial Thrust design offers ruggedness even under heavy duty conditions.

SUCTION COVER

The suction cover is designed to guarantee a long life time even under stress, in fact it's a lined armoured piece made around a strong metal core on PFA execution.



RUNSAFESIC MICROCRYSTALLINE DIAMOND COATING

- Lowest coefficient of friction and heat generation, even when lubrication is insufficient or under dry running condition.



- Universal chemical resistance.
- Increased service life.
- Virtually no wearing of the diamond coating.
- Significant energy savings.

PAINTING COATING QUALITY

The metal surfaces are protected by a high performance three coating layers (240 micron):

- Epoxy zinc pain
- Epoxy amidic modified vinyl
- Epoxy enamel paint or aliphatic acrylic polyurethane

Available upon request :

EN ISO 12944-5 C5M and

C5I protecting paint system grades.



SECTIONAL DRAWING

UTN-L

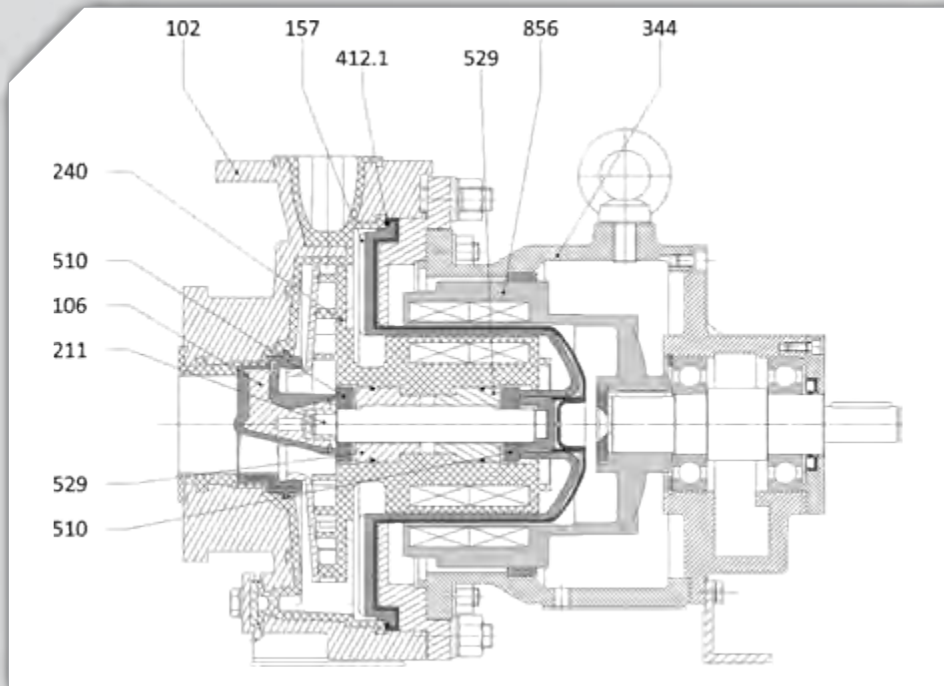

UTN-BL

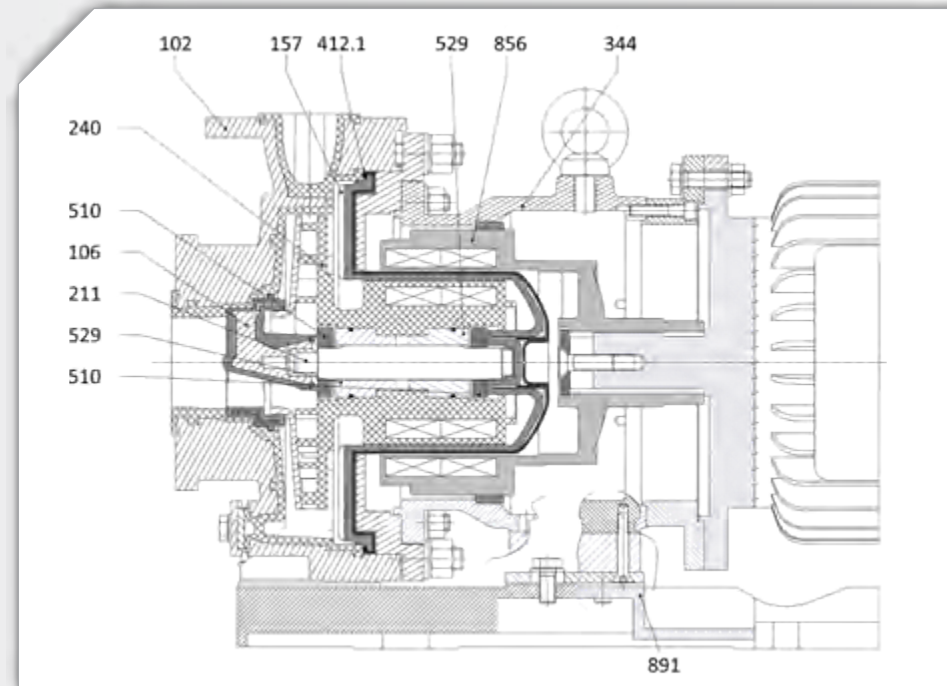

Technical Specifications

Performances 2900 rpm	Q max = 75 m ³ /h - H max = 65 mcl
Electric Motors	<ul style="list-style-type: none"> • UTN-BL: 1.1 kW (motor size 80) -> 18.5 kW (motor size 160) • UTN-L: 0.75 kW (motor size 80) -> 37 kW (motorsize 200)
Temperature range	<ul style="list-style-type: none"> • PP: - 10 °C -> +70 °C • PVDF: - 30 °C -> +100 °C • PFA: - 50 °C -> +140 °C
Allowable Pressure Range	<ul style="list-style-type: none"> • PP: from 16 bar (20 °C) to 12 bar (70 °C) • PVDF: from 16 bar (20 °C) to 8 bar (100 °C) • PFA: from 16 bar (20 °C) to 8 bar (140 °C)
Flange Connections	UNI 1092-2 / ISO 7005-2 PN 16RF, type B slotted to ASME /ANSI class 150
Viscosity	min : 1 cSt min - max : 100 cSt
Allowable Solids	<ul style="list-style-type: none"> • Max concentration 3 % by weighth • Max particle size 0,25 mm

Part list

DIN	Component	Material
102	Casing	PP lined \ PVDF lined \ PFA lined
106	Suction Casing	PP-GF \ PVDF-CF \ PFA lined
157	Isolation Shell	PP-GF \ PVDF-CF \ PFA+CF
211	Shaft	SiC \ Al2O3 \ RunSafe SiC
240	Impeller Assembly	PP lined \ PVDF lined \ PFA lined
344	Lantern	GS400
412.1	O-Ring Casing	EPDM \ FPM \ FPM enc. FEP
510	Thrust Bearing	SiC \ Al2O3 \ RunSafe SiC
529	Rotating Bushing	SiC \ PTFE-Al2O3 \ Graphite \ RunSafe SiC
856	Outer Magnet	GS400+Ryton
891	Pump foot pad	GS400

PERFORMANCE FIELDS

50 Hz

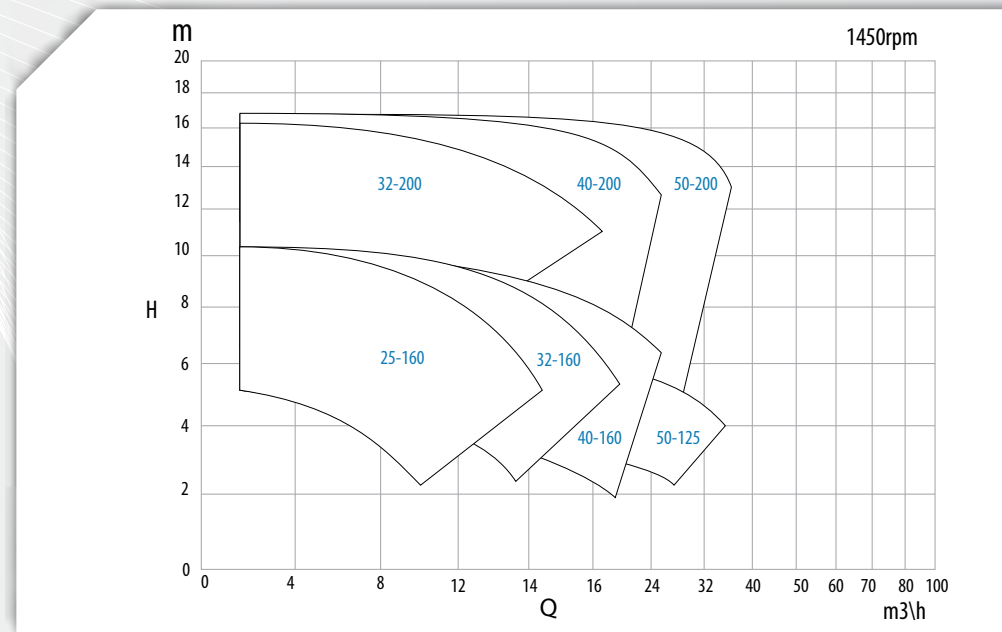
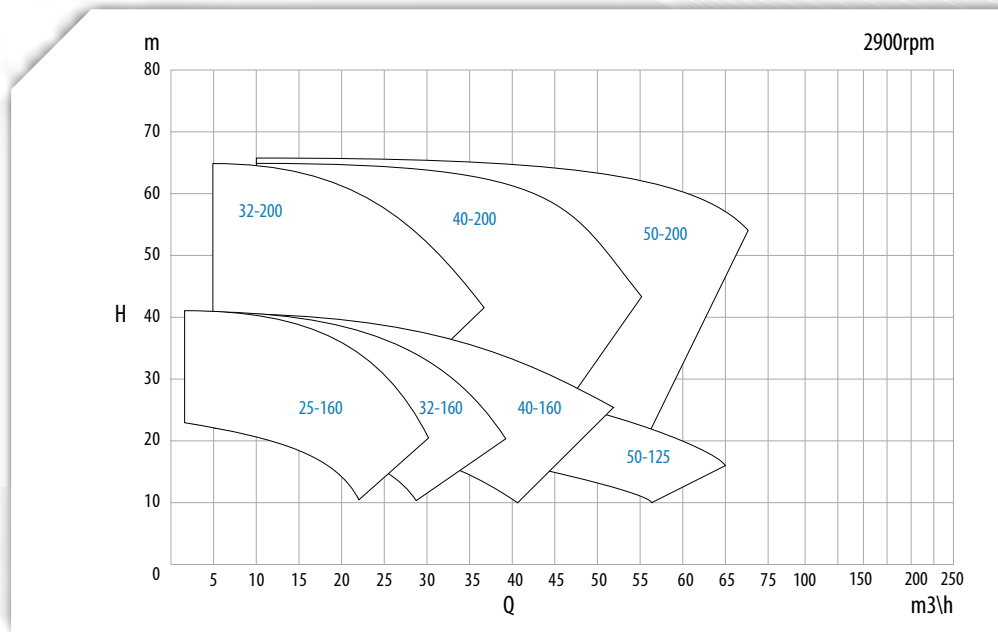

60 Hz

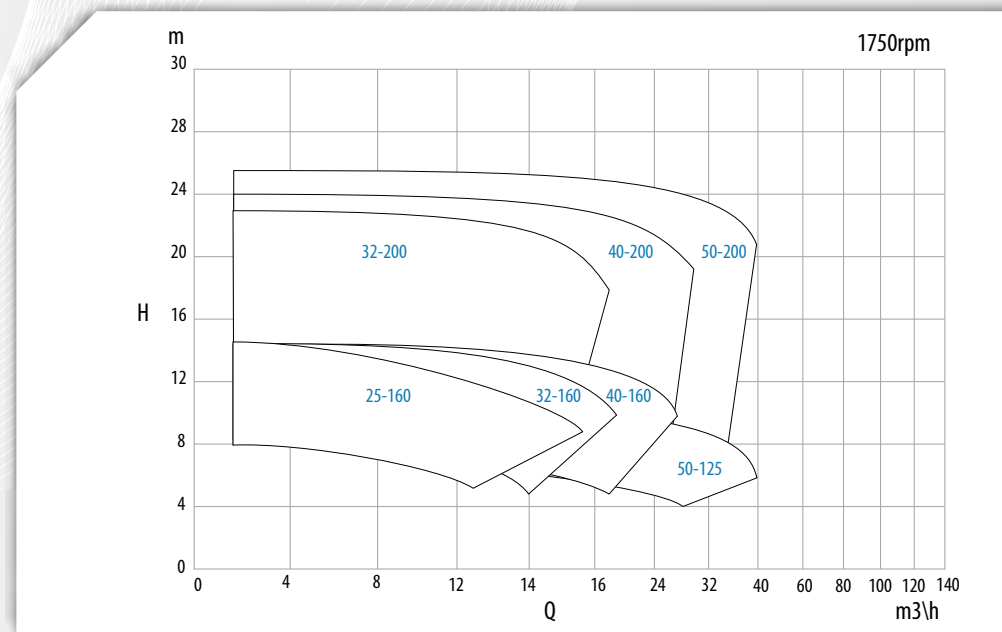
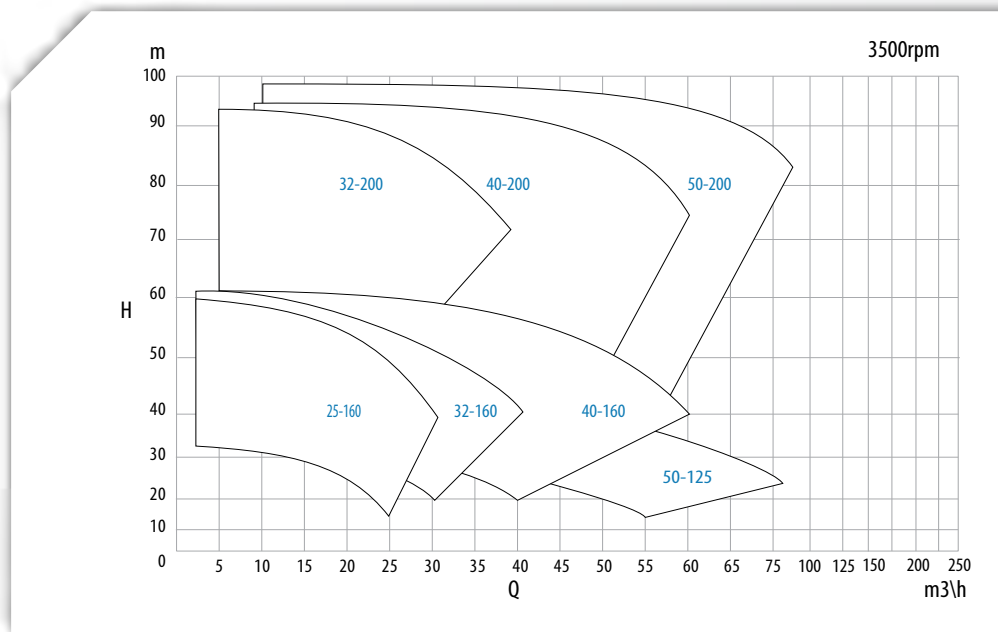

OVERALL DIMENSIONS

UTN-BL CLOSE COUPLED EXECUTION

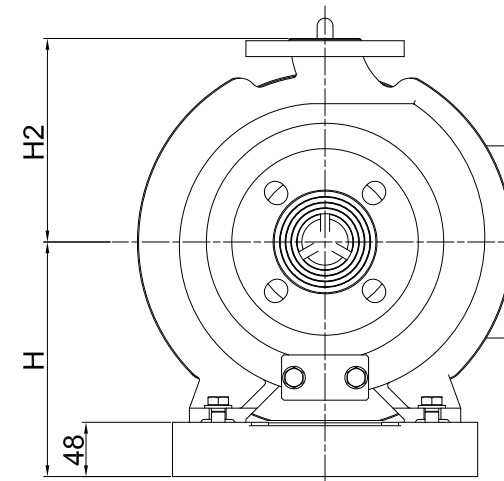
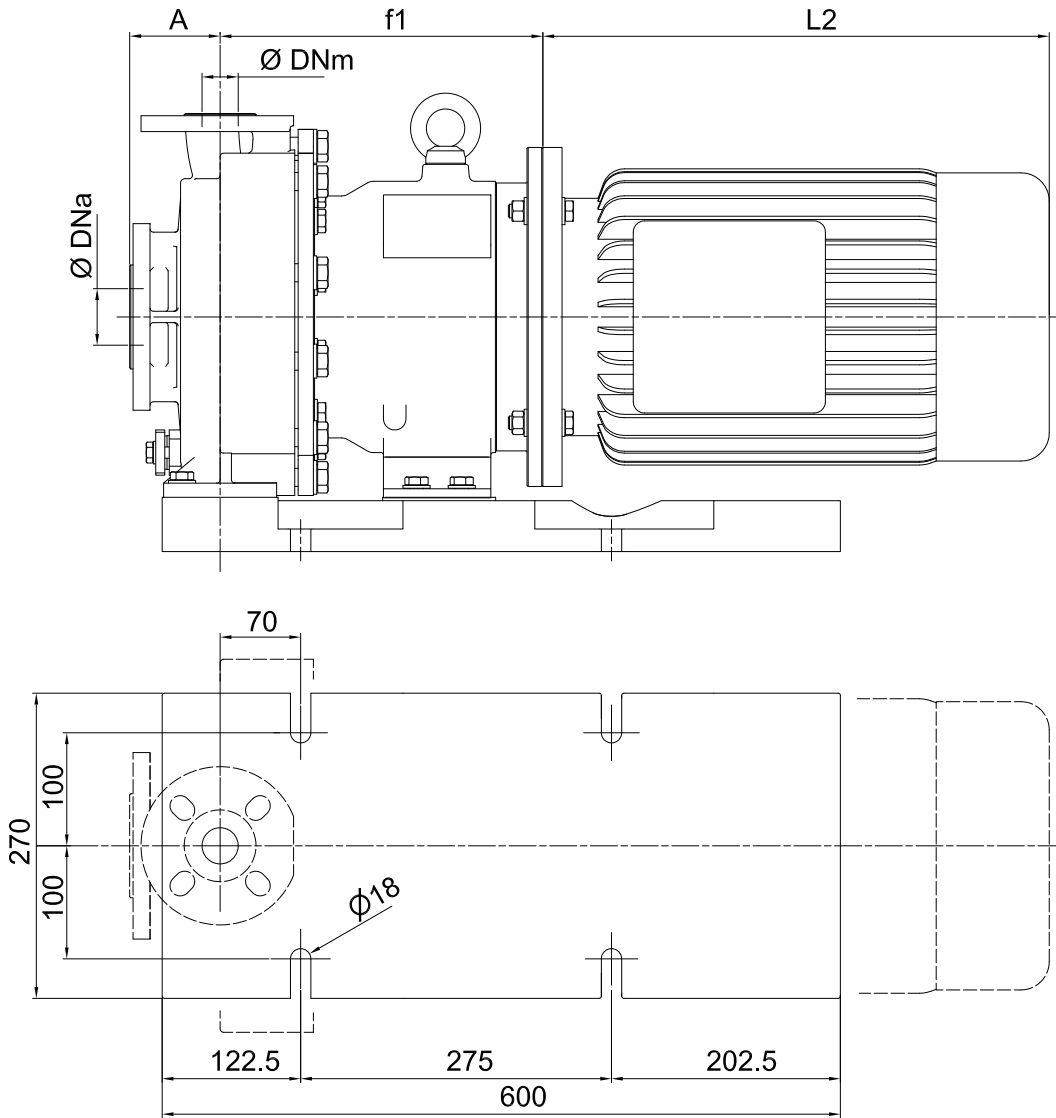

Pump Model	Weight (w/o motor)
UTN-BL 40-25-160	40kg
UTN-BL 50-32-160	45kg
UTN-BL 65-40-160	75kg
UTN-BL 80-50-125	50kg
UTN-BL 50-32-200	75kg
UTN-BL 65-40-200	80kg
UTN-BL 80-50-200	85kg

Motor Size	f1	Frame
	mm	
80	257	B5
90	257	
100	257	
112	257	
132	287	
160	305	

Pump Model	Dna		DNm		A	H	H2
	mm	mm	mm	mm	mm	mm	mm
UTN-BL 40-25-160	40	UNI EN 1092-1 PN 16RF slotted to ANSI 150	25	UNI EN 1092-1 PN 16RF slotted to ANSI 150	80	180	160
UTN-BL 50-32-160	50		32				
UTN-BL 65-40-160	65		40				
UTN-BL 80-50-125	80		50		100	180*	
UTN-BL 50-32-200	50		32		80	208	180
UTN-BL 65-40-200	65		40		100		
UTN-BL 80-50-200	80	50			200		

*size 125 equipped with motor frame 160: H=208

* L2 dimension is according to installed motor manufacturer

OVERALL DIMENSIONS

UTN-L LONG COUPLED EXECUTION

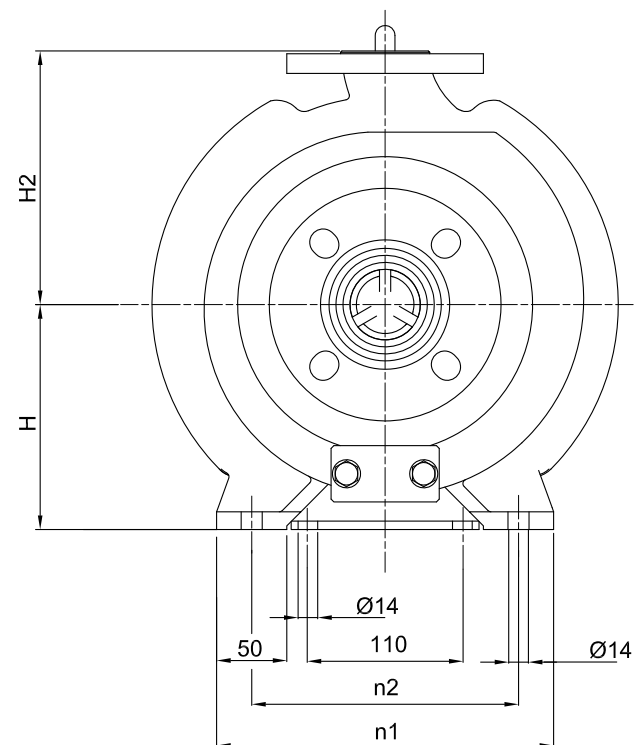
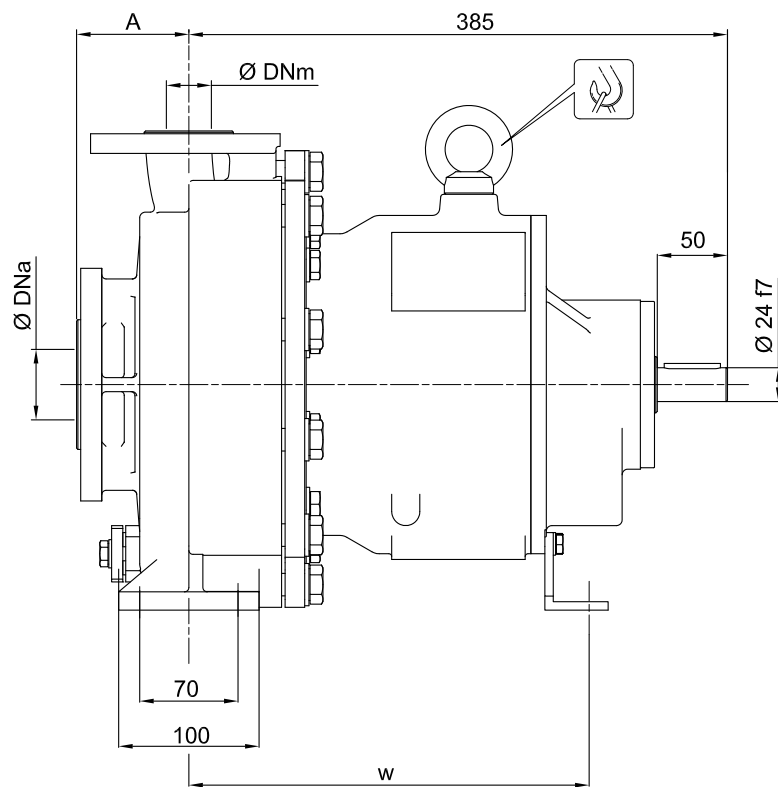

Pump Model	$\varnothing DNa$		$\varnothing DNm$		A	w	H	H2	n1	n2
					mm	mm	mm	mm	mm	mm
UTN-L 40-25-160	40	UNI EN 1092-1 PN 16RF slotted to ANSI 150	25	UNI EN 1092-1 PN 16RF slotted to ANSI 150	80	285	132	160	240	190
UTN-L 50-32-160	50		32							
UTN-L 65-40-160	65		40							
UTN-L 80-50-125	80		50							
UTN-L 50-32-200	50		32		100	160	180			
UTN-L 65-40-200	65		40							
UTN-L 80-50-200	80		50					100	200	262

Pump Model	Weight (w/o motor)
UTN-L 40-25-160	40kg
UTN-L 50-32-160	45kg
UTN-L 65-40-160	75kg
UTN-L 80-50-125	50kg
UTN-L 50-32-200	75kg
UTN-L 65-40-200	80kg
UTN-L 80-50-200	85kg

* L4 dimension is according to installed motor manufacturer

OVERALL DIMENSIONS

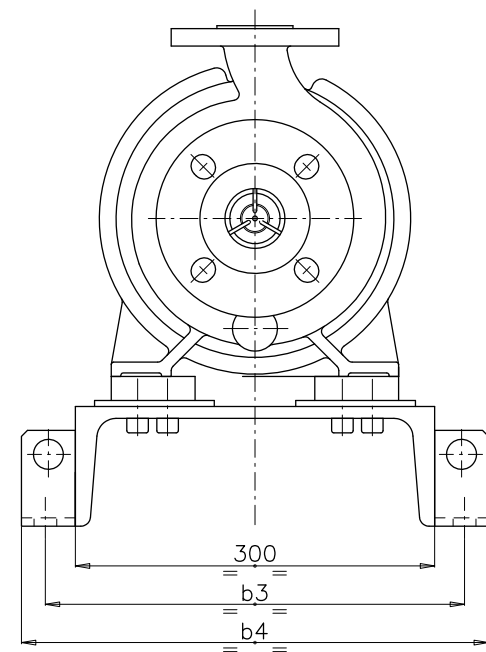
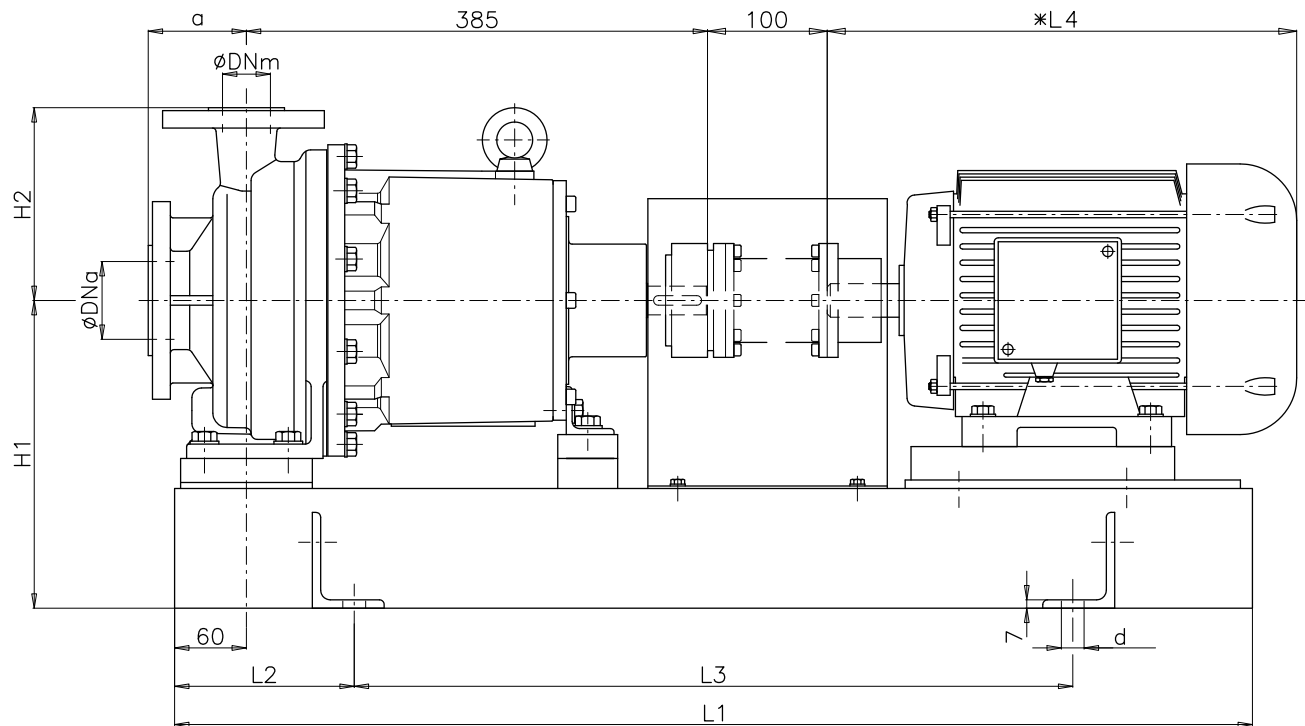

Baseplate Arrangement					Motor Size					
					90	100	112	132	160	180
Pump model	DNa UNI EN 1092-2 PN 16RF slotted to ANSI 150	DNm UNI EN 1092-2 PN 16RF slotted to ANSI 150	a	H2	H1					
	∅	∅	mm	mm	mm	mm	mm	mm	mm	mm
UTN-L 40-25-160	40	25	80	165	257	257	257	272	272	292
UTN-L 50-32-160	50	32		160	257	257	257	272	272	292
UTN-L 65-40-160	65	40		180	270	270	270	300	300	300
UTN-L 80-50-125	80	50		160	257	257	257	272	272	292
UTN-L 50-32-200	50	32	100	180	270	270	270	300	300	300
UTN-L 65-40-200	65	40		160	257	257	257	272	272	292
UTN-L 80-50-200	80	50		200	270	270	270	300	300	300

Motor Size	L1	L2	L3	b3	b4	d
	mm	mm	mm	mm	mm	∅ mm
80-90 100-112	900	150	600	350	390	19
132	1000	170	660	400	450	24
160-180	1120	190	740	440	490	24

* L4 dimension is according to installed motor manufacturer

UTN-L BASEPLATE INSTALLATION

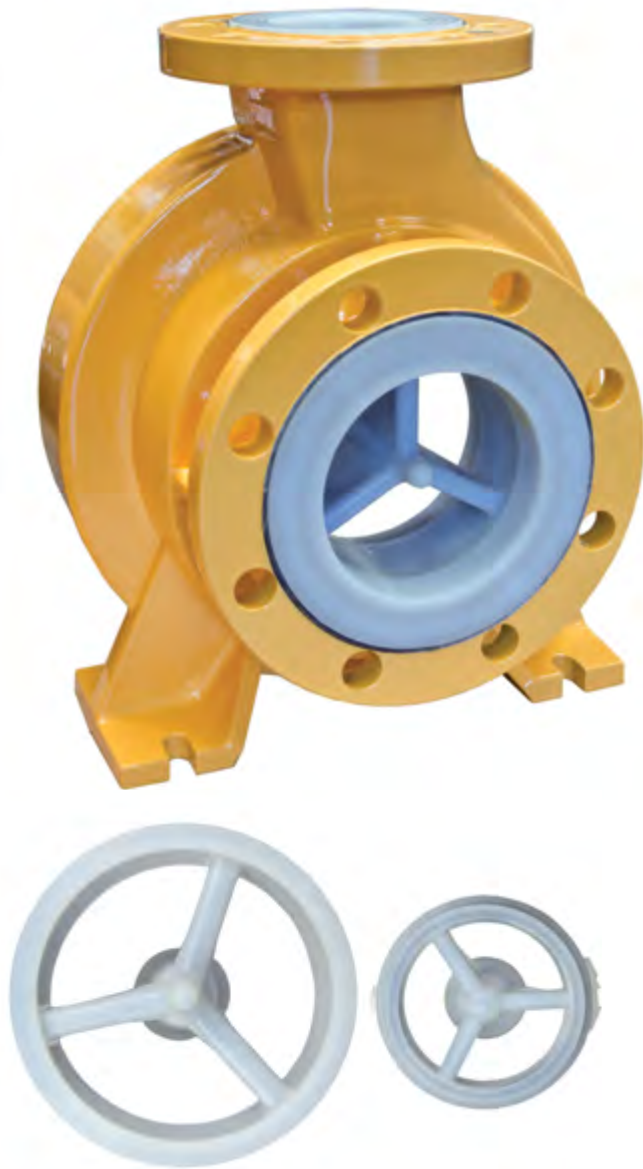

UTN 125-80-160 casing : new 125-80-160 casing is matching perfectly the impeller design , to achieve the best hydraulic efficiency.

The benefits of the lined technology are :

- stability to increased temperature
- under vacuum working capabilities
- constant coating layer thickness thanks to TM process
- high resistance to the permeation thanks to the TM process (for PFA and PVDF execution)

New Impeller 125-80-160 assembly made in one piece granting the maximum reliability and stability during the pump operation.

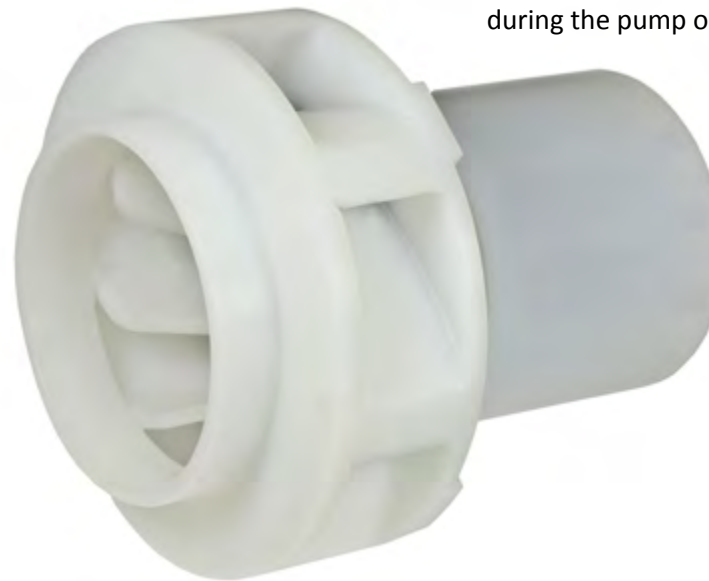

New Suction Cover : using a static shaft design, the new UTN 125-80-160 will have also a new TM Lined suction cover.

The new Suction cover is able to hold the efforts caused on it by the shaft and the Axial Thrust Shoes, moreover 3 generous anti-rotating flat surfaces lock the suction cover into position on the casing.



C.D.R. Pompe S.p.A.

Via P. Togliatti, 26/A - 20030 Senago (MI) - Italy

Tel. +39029901941

Fax +39029980606

www.cdrpompe.com

info@cdrpompe.it

TB-UTN_2014_01



For further info, please
visit
www.cdrpompe.com

Technical Characteristics

The technical data and characteristics stated in this General Catalogue are not binding. CDR Pompe S.p.a. reserves the right to make modifications without notice. Therefore data, dimensions, performances and any other stated issues are indicative only and not binding. Anyway for any technical details you must require an up-to-date product technical card.